



Pump & Motor Catalog

Aluminum Bushing Series

Catalog HY09-1000/US



The Parker Hannifin Gear Pump Division Assures:

- Consistent quality
- Technical innovation
- Premier customer service

Worldwide Sales and Service

Parker operates sales and service centers in major industrial areas worldwide. Call 1-800-C-PARKER for more information, or for a synopsis of the Gear Pump Division, contact a Parker representative.

The Gear Pump Division's ability to engineer specialty products for unique applications has kept us at the forefront of technology, and ensured our position as the industry leader. Our success has come from providing a quality product with excellent sales and service support.

We manufacture hydraulic components for a wide range of industries including:

- Construction
- Refuse/dump truck
- Material handling
- Forestry
- Agriculture
- Industrial



WARNING

FAILURE OR IMPROPER SELECTION OR IMPROPER USE OF THE PRODUCTS AND/OR SYSTEMS DESCRIBED HEREIN OR RELATED ITEMS CAN CAUSE DEATH, PERSONAL INJURY AND PROPERTY DAMAGE.

This document and other information from Parker Hannifin Corporation, its subsidiaries and authorized distributors provide product and/or system options for further investigation by users having technical expertise. It is important that you analyze all aspects of your application and review the information concerning the product or system in the current product catalog. Due to the variety of operating conditions and applications for these products or systems, the user, through its own analysis and testing, is solely responsible for making the final selection of the products and systems and assuring that all performance, safety and warning requirements of the application are met.

The products described herein, including without limitation, product features, specifications, designs, availability and pricing, are subject to change by Parker Hannifin Corporation and its subsidiaries at any time without notice.

Offer of Sale

The items described in this document are hereby offered for sale by Parker Hannifin Corporation, its subsidiaries or its authorized distributors. This offer and its acceptance are governed by the provisions stated in the "Offer of Sale".

© Copyright 2003, Parker Hannifin Corporation, All Rights Reserved.



Parker Hannifin Corporation
Gear Pump Division
Youngstown, Ohio USA

Table of Contents

General Product Information	2	HP Series	
Model P16 Series		General Information	64
General Information	3	Ordering Information	65
Ordering Information	4	HP7 & THP 7 Specifications	66
P16 Specifications	5	Performance Data	66
Performance Data	5	Dimensional Data	66
Dimensional Data	6	HP8 & THP8 Specifications	69
TP16 Specifications 2-Place	7	Performance Data	69
Performance Data	7	Dimensional Data	69
Dimensional Data	8	HP Series Shafts/Mounting Flanges	72
TP16 Specifications 3-Place	10	Gear Motor Series	
Performance Data	10	General Information	73
Dimensional Data	11	Ordering Information	74
Model PVP16 Specifications	12	UM16 Specifications	75
Performance Data	12	Performance Data	75
Dimensional Data	13	Dimensional Data	76
CP16 Specifications	14	M20 Specifications	77
Performance Data	14	Performance Data	77
Dimensional Data	15	Dimensional Data	78
P16 Series Shafts	16	SPM20 Specifications	79
Mounting Flanges	17	Performance Data	79
Cover Plates	18	Dimensional Data	80
Discharge Ports	19	M25 Specifications	81
20 Series		Performance Data	81
General Information	20	Dimensional Data	82
Ordering Information	21	TM25 Specifications	83
20 Specifications	22	Performance Data	83
Performance Data	22	Dimensional Data	83
Dimensional Data	23	SPM25 Specifications	84
Bodies Available	23	Performance Data	84
TP20 Specifications 2-Place	24	Dimensional Data	85
Performance Data	24	Gear Motor Shafts	86
Dimensional Data	25	Gear Motor Cover Plates	87
TP20 Specifications 3-Place	27	Gear Motor Mounting Flanges	88
Performance Data	27	Dry Valve Series	
Dimensional Data	28	General Information	90
R20 Specifications	30	Ordering Information	91
Performance Data	30	DVP16 Specifications	92
Dimensional Data	31	Performance Data	92
PB20 Specifications	32	Dimensional Data	93
Performance Data	32	DV20 Specifications	94
Dimensional Data	33	Performance Data	94
NST20 Specifications	35	Dimensional Data	95
Performance Data	35	DV25 Specifications	96
Dimensional Data	36	Performance Data	96
NSD 20 Specifications	38	Dimensional Data	97
Performance Data	38	Dry Valve Shafts	98
Dimensional Data	39	Dry Valve Mounting Flanges	100
NSH20 Specifications	41	ES Flow Control Specifications	102
Performance Data	42	ER Dry-Valve Dimensional Data	103
Dimensional Data	43	Wet Pump Series	
NDS20 Specifications	44	General Information	104
Performance Data	44	Ordering Information	105
Dimensional Data	45	FPW257 Series Specifications	106
NSHD20 Specifications	47	Performance Data	106
Performance Data	47	Dimensional Data	106
Dimensional Data	48	Wet Pump Shafts & Mounting Flanges	108
PSH20 Specifications	50	Wet Pump Flow Regulators	109
Performance Data	50	Accessories	
Dimensional Data	51	With Manual Shift	110
20 Series Shafts/Mounting Flanges	52	With Solenoid Shift	110
Couplings/Transition Plates	53	Accessories – Other	111
25 Series		Warning Notes	111
General Information	54	Connectors	111
Ordering Information	55	Offer of Sale	112
25 Specifications	56		
Performance Data	56		
Dimensional Data	57		
TP25 Specifications	58		
Performance Data	58		
Dimensional Data	59		
PB25 Specifications	60		
Performance Data	60		
Dimensional Data	61		
25 Series Shafts/Mounting Flanges	62		
Couplings/Transition Plates	63		

All units shown in this catalog are of aluminum construction to provide superior performance, while affording excellent horsepower-to-weight ratio.

P16 SERIES

- Flows to 37 GPM per section
- Tandem & triple section units available
- Pressures to 3000 PSI
- Speeds to 3600 RPM
- Also available as motor
- Priority flow available
- Dry valve option
- Clutch pump available

20 SERIES

- Flows to 98 GPM per section
- Tandem & triple section units available
- Pressures to 2500 PSI
- Speeds to 2500 RPM
- Pressure & flow sensing valves available
- Dry valve option
- Piggy back option available
- Also available as motor
- Cast iron versions available

25 SERIES

- Flows to 208 GPM per section
- Tandem section units available
- Pressures to 3000 PSI
- Speeds to 2500 PSI
- Piggy back option available
- Dry Valve option
- Also available as motor
- Cast irons versions available

HP 7 SERIES

- Flows to 116 GPM per section
- Tandem section units available
- Pressures to 4000 PSI
- Speeds to 2500 RPM

HP 8 SERIES

- Flows to 177 GPM per section
- Tandem section units available
- Pressures to 4000 PSI
- Speeds to 2500 RPM

**General Information
for P16 Series**

- Available in various configurations
 - P16 — Single Section
 - TP16 — Tandem, 2 & 3 Place
 - PVP16 — Priority Valve
 - CP16 — Clutch Pump 'V' Belt and Serpentine
- Cast iron pumping sections for durability
- Aluminum flanges and covers for optimum power to weight ratio.
- Journal bearings for long life and good over-hung load capability
- Buna-N Seals are standard for petroleum and glycol based fluids. "Viton®E" seals are optional.
- Pressure balanced plates for greater efficiency.

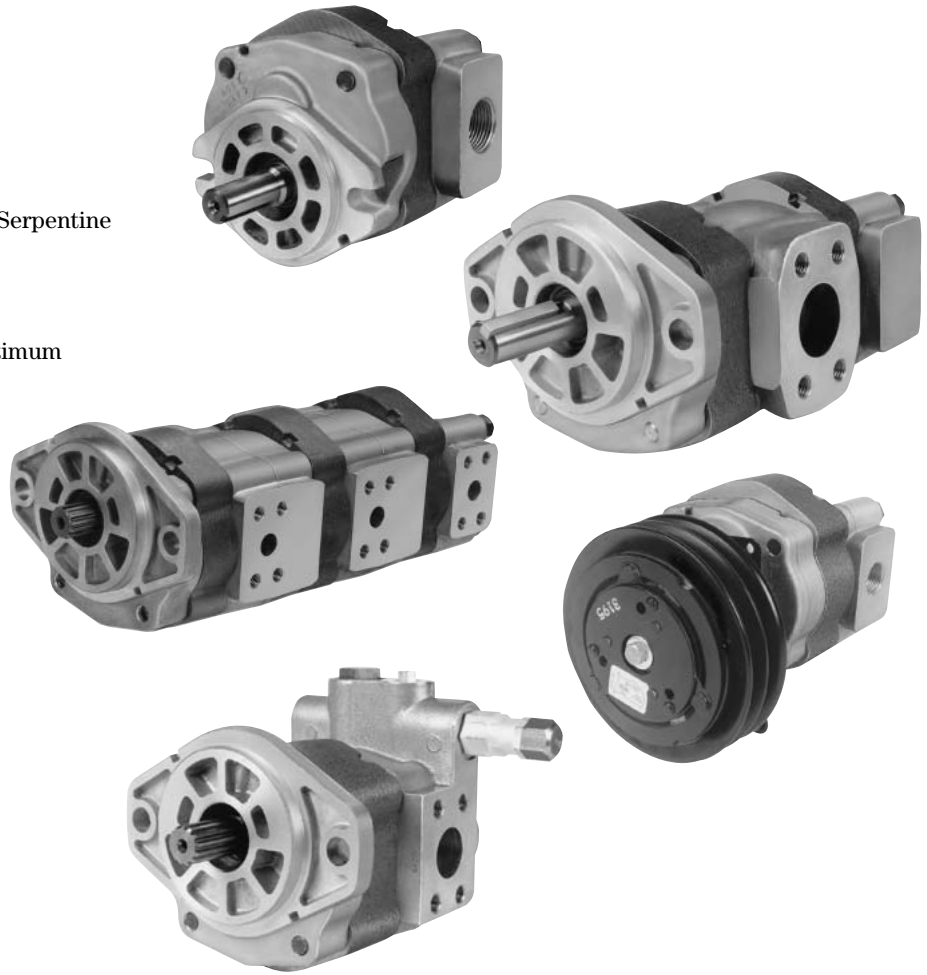

How to Order P16 Series:

Select the desired symbol (in the correct position) to construct a model code.

Assembly Example:

OPTIONS	
Code	Description
V	Viton®

MODEL	
Code	Description
P	Pump (single)
TP	Tandem Pump
PVP	Priority Valve Pump
CP	Clutch Pump

SECTION SIZE		
Code	Cu. In./ Rev.	CC's/ Rev.
45	.878	14.388
65	1.270	20.812
85	1.663	27.252
100	1.964	32.184
115	2.241	36.723
150	2.934	48.080
180	3.511	57.535
200	3.902	63.942

COVER PLATE (FOR MODEL CP)			
Code	Port	Inlet	Outlet
1	Rear	#20 SAE (1-5/8"-12UN-2B)	#16 SAE (1-5/16"-12UN-2B)
2	Rear	1" NPT	3/4" NPT
3	Side	1-1/4" 4-Bolt	3/4" 4-Bolt
4	Side	1" NPT	3/4" NPT
5	Side	#20 SAE (1-5/8"-12UN-2B)	#12 SAE (1-1/16"-12UN-2B)
6	Rear	#16 SAE (1-5/16"-12UN-2B)	#12 SAE (1-1/16"-12UN-2B)
7	Rear	1" BSPT	3/4" BSPT
8	Side	1" BSPT	3/4" BSPT
9	Side	#20 SAE (1-5/8"-12UN-2B)	#16 SAE (1-1/16"-12UN-2B)
10	Side/Rear	1-1/4" 4-Bolt	#12 SAE (1-1/16"-12UN-2B)
11	Side	1-1/4" 4-Bolt	#12 SAE (1-1/16"-12UN-2B)

ROTATION	
Code	Direction
A	C'C' Wise
C	C' Wise

SHAFT	
Code	Description
1	5/8" 9-Tooth Spline
2	7/8" 13-Tooth Spline
3	7/8" Straight Keyed
5	7/8" Straight Keyed Long
6	3/4" Straight Keyed
8	7/8" Straight Keyed w/ 5/8" Thread
9	7/8" Tapered

CLUTCH	
Code	Drive Type
0	None
1	V-Belt - Light Duty
2	V-Belt - Heavy Duty
3	Direct Drive
4	6-Rib Flat Belt

FLANGE	
Code	Mounting
D	SAE 'A' 2-Bolt
E	6-Bolt Round
F	Pad (Foot) Mount
G	SAE 'C' 4-Bolt
J	SAE 'B' 4-Bolt
N	SAE 'B' 2-Bolt
S	PTO Direct
T	PTO Direct (Chelsea SPL.)
NONE	Omit For Clutch Pumps

OR

SWITCH KIT	
Code	Switch Kit
S	With Switch Kit
O	Without Switch Kit

OR

COVER PLATE (FOR MODEL P, TP, & PVP)			
Code	Port	Inlet	Outlet
1	Side	#20 SAE (1-5/8"-12UN-2B)	#16 SAE (1-5/16"-12UN-2B)
2	Rear	1" NPT	3/4" NPT
3	Side	1-1/4" 4-Bolt	3/4" 4-Bolt
4	Side	1" NPT	3/4" NPT
5	Side	#20 SAE (1-5/8"-12UN-2B)	#12 SAE (1-1/16"-12UN-2B)
6	Rear	#16 SAE (1-5/16"-12UN-2B)	#12 SAE (1-1/16"-12UN-2B)
7	Rear	1" BSPT	3/4" BSPT
8	Side	1" BSPT	3/4" BSPT
9	Side	#20 SAE (1-5/8"-12UN-2B)	#16 SAE (1-1/16"-12UN-2B)
10	Side/Rear	1-1/4" 4-Bolt	#12 SAE (1-1/16"-12UN-2B)
11	Side	1-1/4" 4-Bolt	#12 SAE (1-1/16"-12UN-2B)

*Consult factory for priority flows over 10 GPM.
 Note: Add prefix 'V' to pump model number (VP16) when ordering pumps with Viton® Seals.

PRIORITY PVP ONLY	
Code	Flow
1	1-2
2	2-3
3	3-4
4	4-5
5	5-6
6	6-7
7	7-8
8	8-9
9	9-10

PRESSURE SETTING	
Code	Setting
5	500 PSI
10	1000 PSI
12	1200 PSI

Use 2 digit maximum to indicate pressure setting

Consult Factory For Flows Greater than 10 GPM

**Specifications
for P16 Series**

Description Gear Pumps
Flow Range TO 38 GPM (143.8 LTR)
Displacements TO 3.902 C.I.R. (63.94 CC's/REV.)
Maximum Pressure to 3000 PSI (207 BAR)
Maximum Speed to 3600 RPM
Rotation A or C
Bearings Journal
Construction Cast Iron Gear Plate with
Aluminum Flange and Cover Plate

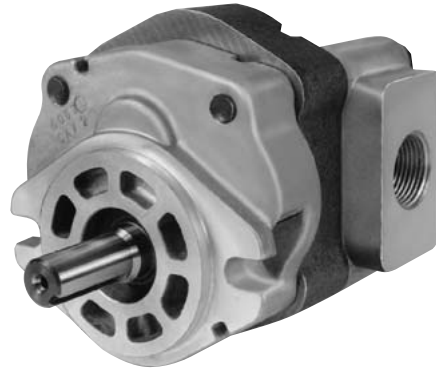

Performance Data

Pump Model	Section Size	Displacement/Revolution (Theoretical)					Maximum Pressure		Maximum Speed RPM
		US Gallons	Cubic Inches	Liters	Cubic Centimeters	Imperial Gallons	PSI	BAR	
P16	45	.0038	.878	.0144	14.388	.0031	3000	207	3600
P16	65	.0055	1.270	.0208	20.812	.0045	3000	207	3600
P16	85	.0072	1.663	.0273	27.252	.0059	3000	207	3400
P16	100	.0085	1.964	.0321	32.184	.0070	3000	207	3300
P16	115	.0097	2.241	.0367	36.723	.0080	3000	207	3100
P16	150	.0127	2.934	.0481	48.080	.0105	3000	207	2800
P16	180	.0152	3.511	.0575	57.535	.0126	2200	152	2500
P16	200	.0169	3.902	.0639	63.942	.0140	2000	138	2200

All data based on SAE 10W oil at 150°F.
Available with Viton® Seals.

CAUTION: "Inlet vacuum" should not exceed 5" Hg at normal operating speed and temperature.
Operation of pumps in excess of 5" Hg requires factory approval.

Dimensional Data

Pump Models	Flange Type						Shipping Weights (Approx.)	
	D		E		F		lbs.	kgs.
	A	B	A	B	A	B		
P16 - 45	89.9 (3.54)	115.6 (4.55)	118.4 (4.66)	144.1 (5.67)	92.9 (3.66)	118.6 (4.67)	12	5.5
P16 - 65	95.3 (3.75)	121.2 (4.77)	123.6 (4.88)	149.6 (5.89)	98.6 (3.88)	124.2 (4.89)	13	5.9
P16 - 85	100.9 (3.97)	126.5 (4.98)	129.3 (5.09)	154.9 (6.10)	103.6 (4.09)	129.5 (5.10)	14	6.4
P16 - 100	104.9 (4.13)	130.6 (5.14)	133.3 (5.25)	159.0 (6.26)	107.9 (4.25)	133.6 (5.26)	15	6.8
P16 - 115	108.9 (4.29)	134.6 (5.30)	137.4 (5.41)	163.1 (6.42)	112.0 (4.41)	137.7 (5.42)	16	7.3
P16 - 150	118.4 (4.66)	144.1 (5.67)	146.8 (5.78)	172.5 (6.79)	121.4 (4.78)	147.1 (5.79)	17	7.7
P16 - 180	126.5 (4.98)	152.2 (5.99)	154.9 (6.10)	180.6 (7.11)	129.5 (5.10)	155.2 (6.11)	19	8.6
P16 - 200	131.8 (5.19)	157.5 (6.20)	160.3 (6.31)	185.9 (7.32)	134.9 (5.31)	160.5 (6.32)	20	9.1

Pump Models	Flange Type						Shipping Weights (Approx.)	
	G&J		N		S&T		lbs.	kgs.
	A	B	A	B	A	B		
P16 - 45	118.4 (4.66)	144.1 (5.67)	88.1 (3.47)	113.8 (4.48)	132.6 (5.22)	158.2 (6.23)	12	5.5
P16 - 65	123.6 (4.88)	149.6 (5.89)	93.7 (3.69)	119.4 (4.70)	138.2 (5.44)	163.8 (6.45)	13	5.9
P16 - 85	129.3 (5.09)	154.9 (6.10)	99.1 (3.90)	124.7 (4.91)	143.5 (5.65)	169.2 (6.66)	14	6.4
P16 - 100	133.3 (5.25)	159.0 (6.26)	103.1 (4.06)	128.8 (5.07)	147.6 (5.81)	173.2 (6.82)	15	6.8
P16 - 115	137.4 (5.41)	163.1 (6.42)	107.2 (4.22)	132.8 (5.23)	151.6 (5.97)	177.3 (6.98)	16	7.3
P16 - 150	146.8 (5.78)	172.5 (6.79)	116.6 (4.59)	142.2 (5.60)	161.0 (6.34)	186.7 (7.35)	17	7.7
P16 - 180	154.9 (6.10)	180.6 (7.11)	124.7 (4.91)	150.4 (5.92)	169.2 (6.66)	194.8 (7.67)	19	8.6
P16 - 200	160.3 (6.31)	185.9 (7.32)	130.1 (5.12)	155.7 (6.13)	174.5 (6.87)	200.1 (7.88)	20	9.1

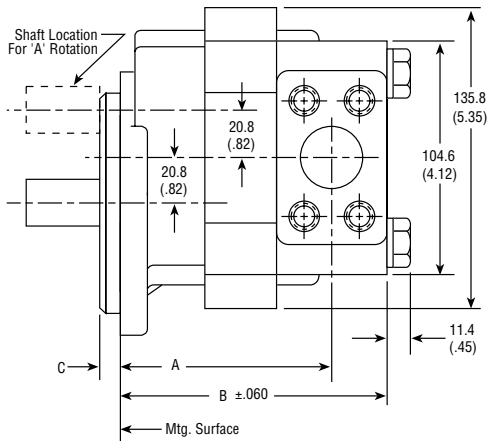

C Dimensions

FLANGE TYPE	MM	IN
D	6.35	(.250)
E	4.74	(.187)
F	—	—
G	6.35	(.250)
J	6.35	(.250)
N	9.52	(.375)
S	5.08	(.200)
T	5.08	(.200)

Inch equivalents for millimeter dimensions are shown in (**).

**Specifications
for TP16 Series**

Description Gear Pumps (Two-place)
Flow Range To 32 GPM (121.1 LTR) Per Section
Displacements To 3.904 C.I.R. (63.94 CC's/REV.)
Maximum Pressure to 3000 PSI (207 BAR)
Maximum Speed to 3100 RPM
Rotation A or C
Bearings Journal
Construction Cast Iron Gear Plates with
Aluminum Flange, Connector and Cover Plates



Performance Data Per Section

Pump Model	Section Size	Displacement/Revolution (Theoretical)					Maximum Pressure		Maximum Speed
		US Gallons	Cubic In	Liters	Cubic Cm	Imperial Gallons	PSI	BAR	RPM Tandem
TP16	45	.0038	.878	.0144	14.388	.0031	3000	207	3100
TP16	65	.0055	1.270	.0208	20.812	.0045	3000	207	3000
TP16	85	.0072	1.663	.0273	27.252	.0059	3000	207	2900
TP16	100	.0085	1.964	.0321	32.184	.0070	3000	207	2800
TP16	115	.0097	2.241	.0367	36.723	.0080	3000	207	2600
TP16	150	.0127	2.934	.0481	48.080	.0105	3000	207	2400
TP16	180	.0152	3.511	.0575	57.535	.0126	2200	152	2100
TP16	200	.0169	3.904	.0639	63.942	.0140	2000	138	1900

Note: For best inlet conditions, place largest displacement section in the rear position and use both inlet ports.
All data based on SAE 10W oil at 150°F.
Available with Viton® Seals.



CAUTION: "Inlet vacuum" should not exceed 5" Hg at normal operating speed and temperature.
Operation of pumps in excess of 5" Hg requires factory approval.

Dimensional Data

PD Factors

The maximum size and number of sections of a tandem pump for a given application is limited to the torque capability of the input drive shaft and the spline coupling between the sections. To determine this capability, a "PD Factor" is used:

Maximum allowable PD for the 7/8" drive shaft is 53.
 Maximum allowable PD for a coupling is also 53.

When: P = PSI (The relief valve setting of each individual section).

D = Displacement (In U.S. gallons per revolution of each individual section).

Example: Assume a two-place pump TP16-150 — 150 with front and rear sections on pressure at the same time at 2000 PSI:

- A. Drive Shaft:
 $PD = (2000) (.0127) + (2000) (.0127) = 50.8$ vs. 53. Capability is OK
- B. Coupling between front and center sections:
 $PD = (2000) (.0127) = 25.4$ vs. 53. Capability is OK.

Flange Dimensions

FLANGE TYPE	E		F	
D	6.35	(.250)	41.15	(1.62)
E	4.75	(.187)	69.85	(2.75)
F	—	—	44.45	(1.75)
J	6.35	(.250)	69.85	(2.75)
N	9.52	(.375)	38.10	(1.55)
S	5.08	(.200)	84.07	(3.31)

Inch equivalents for millimeter dimensions are shown in (**).

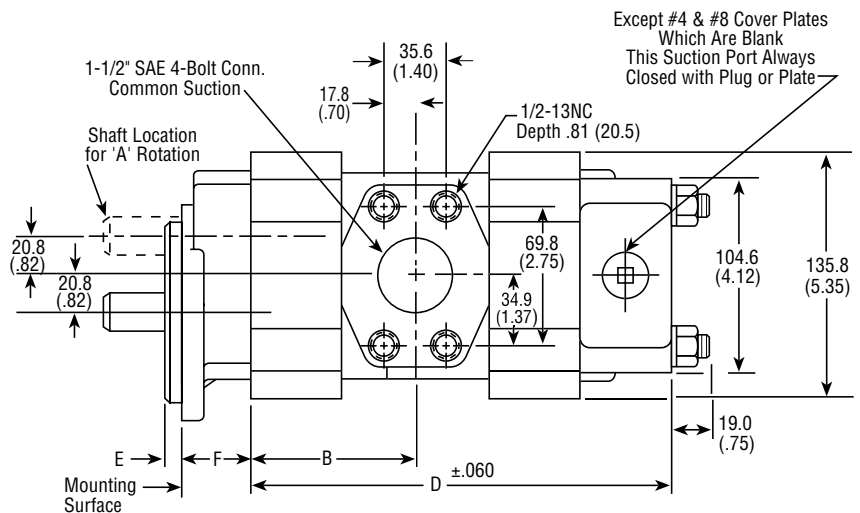
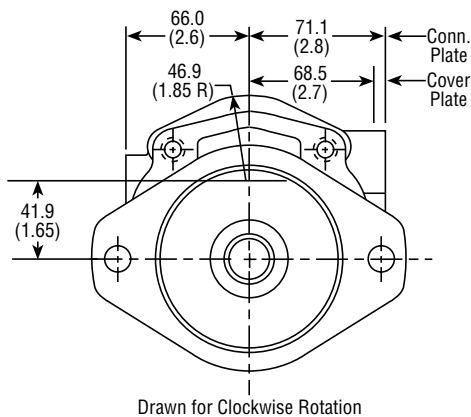
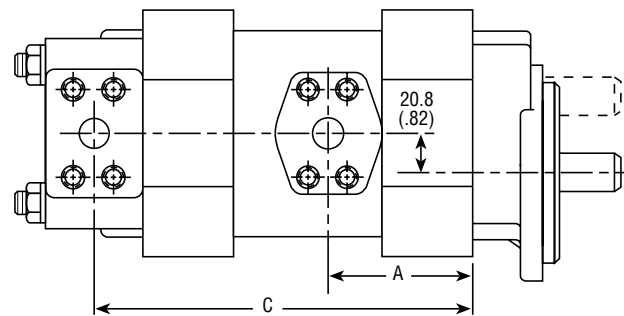

Dimensional Data

PUMP SIZES	A		B		C		D		Shipping Weights (Approx.)	
	lbs.	kgs.	lbs.	kgs.	lbs.	kgs.	lbs.	kgs.	lbs.	kgs.
TP16-45-45	48.01	(1.89)	61.47	(2.42)	149.9	(5.90)	175.5	(6.91)	26	11.8
TP16-65-45	53.59	(2.11)	67.06	(2.64)	155.2	(6.11)	180.9	(7.12)	28	12.7
TP16-65-65	53.59	(2.11)	67.06	(2.64)	160.8	(6.33)	186.4	(7.34)	30	13.6
TP16-85-45	58.93	(2.32)	72.39	(2.85)	160.8	(6.33)	186.4	(7.34)	31	14.1
TP16-85-65	58.93	(2.32)	72.39	(2.85)	166.1	(6.54)	191.8	(7.55)	33	15.0
TP16-85-85	58.93	(2.32)	72.39	(2.85)	171.7	(6.76)	197.4	(7.77)	35	15.9
TP16-100-45	62.99	(2.48)	76.45	(3.01)	164.9	(6.49)	190.5	(7.50)	34	15.4
TP16-100-65	62.99	(2.48)	76.45	(3.01)	170.2	(6.70)	195.8	(7.71)	36	16.3
TP16-100-85	62.99	(2.48)	76.45	(3.01)	175.8	(6.92)	201.4	(7.93)	38	17.2
TP16-100-100	62.99	(2.48)	76.45	(3.01)	179.8	(7.08)	205.5	(8.09)	39	17.7
TP16-115-45	67.06	(2.64)	80.52	(3.17)	168.9	(6.65)	194.6	(7.66)	39	17.7
TP16-115-65	67.06	(2.64)	80.52	(3.17)	174.2	(6.86)	199.9	(7.87)	41	18.6
TP16-115-85	67.06	(2.64)	80.52	(3.17)	179.8	(7.08)	205.5	(8.09)	43	19.5
TP16-115-100	67.06	(2.64)	80.52	(3.17)	183.9	(7.24)	209.6	(8.25)	44	20.0
TP16-115-115	67.06	(2.64)	80.52	(3.17)	188	(7.40)	213.6	(8.41)	46	20.9
TP16-150-45	76.45	(3.01)	89.92	(3.54)	178.3	(7.02)	204	(8.03)	44	20.0
TP16-150-65	76.45	(3.01)	89.92	(3.54)	183.6	(7.23)	209.3	(8.24)	47	21.3
TP16-150-85	76.45	(3.01)	89.92	(3.54)	189.2	(7.45)	214.9	(8.46)	49	22.2
TP16-150-100	76.45	(3.01)	89.92	(3.54)	193.3	(7.61)	219	(8.62)	50	22.7
TP16-150-115	76.45	(3.01)	89.92	(3.54)	197.4	(7.77)	223	(8.78)	52	23.6
TP16-150-150	76.45	(3.01)	89.92	(3.54)	206.8	(8.14)	232.4	(9.15)	54	24.5
TP16-180-45	84.58	(3.33)	98.04	(3.86)	186.4	(7.34)	212.1	(8.35)	52	23.6
TP16-180-65	84.58	(3.33)	98.04	(3.86)	191.8	(7.55)	217.4	(8.56)	54	24.5
TP16-180-85	84.58	(3.33)	98.04	(3.86)	197.4	(7.77)	223	(8.78)	56	25.4
TP16-180-100	84.58	(3.33)	98.04	(3.86)	201.4	(7.93)	227.1	(8.94)	57	25.9
TP16-180-115	84.58	(3.33)	98.04	(3.86)	205.5	(8.09)	231.1	(9.10)	59	26.8
TP16-180-150	84.58	(3.33)	98.04	(3.86)	214.9	(8.46)	240.5	(9.47)	61	27.7
TP16-180-180	84.58	(3.33)	98.04	(3.86)	223	(8.78)	248.7	(9.79)	63	28.6
TP16-200-45	90.17	(3.55)	103.6	(4.08)	191.8	(7.55)	217.7	(8.57)	60	27.2
TP16-200-65	90.17	(3.55)	103.6	(4.08)	197.1	(7.76)	222.8	(8.77)	62	28.1
TP16-200-85	90.17	(3.55)	103.6	(4.08)	202.7	(7.98)	228.4	(8.99)	64	29.0
TP16-200-100	90.17	(3.55)	103.6	(4.08)	206.8	(8.14)	232.4	(9.15)	65	29.5
TP16-200-115	90.17	(3.55)	103.6	(4.08)	210.8	(8.30)	236.5	(9.31)	67	30.4
TP16-200-150	90.17	(3.55)	103.6	(4.08)	220.2	(8.67)	245.9	(9.68)	69	31.3
TP16-200-180	90.17	(3.55)	103.6	(4.08)	228.4	(8.99)	254	(10.00)	71	32.2
TP16-200-200	90.17	(3.55)	103.6	(4.08)	233.7	(9.20)	259.3	(10.21)	73	33.1

**Specifications
for TP16 Series**

Description Gear Pumps (Three-place)
Flow Range To 32 GPM (121.1 LTR.) Per Section
Displacements To 3.904 C.I.R. (63.94 CC's/REV.)
Maximum Pressure to 3000 PSI (207 BAR)
Maximum Speed to 3100 RPM
Rotation A or C
Bearings Journal
Construction Cast Iron Gear Plates with
Aluminum Flange, Connector and Cover Plates

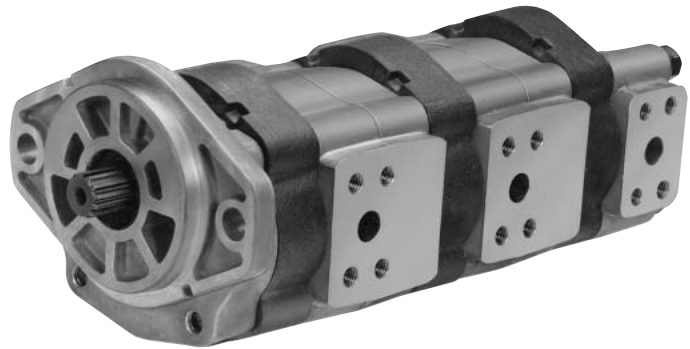

Performance Data Per Section

Pump Model	Section Size	Displacement/Revolution (Theoretical)					Maximum Pressure		Maximum Speed RPM
		US Gallons	Cubic Inches	Liters	Cubic Centimeters	Imperial Gallons	PSI	BAR	
P16	45	.0038	.878	.0144	14.388	.0031	3000	207	3100
P16	65	.0055	1.270	.0208	20.812	.0045	3000	207	3000
P16	85	.0072	1.663	.0273	27.252	.0059	3000	207	2900
P16	100	.0085	1.964	.0321	32.184	.0070	3000	207	2800
P16	115	.0097	2.241	.0367	36.723	.0080	3000	207	2600
P16	150	.0127	2.934	.0481	48.080	.0105	3000	207	2400
P16	180	.0152	3.511	.0575	57.535	.0126	2200	152	2100
P16	200	.0169	3.904	.0639	63.942	.0140	2000	138	1900

Note: Three-place pumps assembled from maximum displacement size sections should be checked for operating inlet conditions.
If "PD Factor" is not exceeded, place the largest displacement section in the rear position and use all inlet ports.
All data based on SAE 10W oil at 150°F.
Available with Viton® Seals.

CAUTION: "Inlet vacuum" should not exceed 5" Hg at normal operating speed and temperature.
Operation of pumps in excess of 5" Hg requires factory approval.

Dimensional Data

To determine overall pump length
 Add together the dimensions that apply to the pump you
 are considering.

- A = _____ Shaft Extension
- B = _____ Flange Length
- C = _____ Front Gear Plate Length
- D = $\frac{79.2 \text{ mm}}{3.12 \text{ in.}}$ Connector Plate Length
- E = _____ Center Gear Plate Length
- F = $\frac{79.2 \text{ mm}}{3.12 \text{ in.}}$ Connector Plate Length
- G = _____ Rear Gear Plate Length
- H = $\frac{52.3 \text{ mm}}{2.06 \text{ in.}}$ Cover Plate Length
- J = $\frac{19.0 \text{ mm}}{.75 \text{ in.}}$ Stud Extension
- _____ Total = Overall Length

PUMP SIZE	C, E & G
-45	21.84 (.86)
-65	27.18 (1.07)
-85	32.77 (1.29)
-100	36.83 (1.45)
-115	40.89 (1.61)
-150	50.29 (1.98)
-180	58.42 (2.30)
-200	63.75 (2.51)

Flange Dimensions

FLANGE TYPE	B	K
D	41.1 (1.62)	6.3 (.250)
E	69.8 (2.75)	4.7 (.187)
F	44.4 (1.75)	—
J	69.8 (2.75)	6.3 (.250)
N	39.3 (1.55)	9.5 (.375)
S	84.0 (3.31)	5.0 (.200)

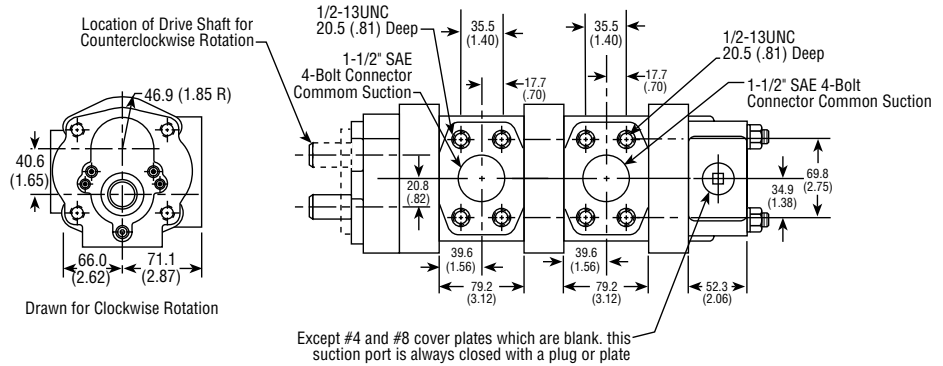
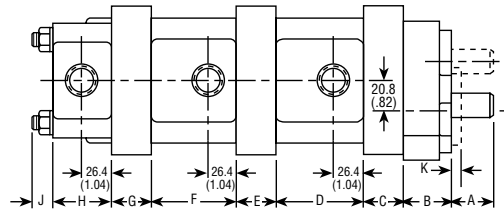

**Inch equivalents for millimeter
 dimensions are shown in (**).**

PD Factors

The maximum size and number of sections of a tandem pump for a given application is limited to the torque capability of the input drive shaft and the spline coupling between the sections. To determine this capability, a "PD Factor" is used:

Maximum allowable PD for the 7/8" drive shaft is 53.
 Maximum allowable PD for a coupling is also 53.

When: P = PSI (The relief valve setting of each individual section).
 D = Displacement (In U.S. gallons per revolution of each individual section).

Example: Assume a three-place pump TP16-150-150-100 with front and center sections on pressure at the same time at 2000 PSI, and with the rear section on pressure at 1500 PSI, but not at the same time as the front and center sections:

- A. Drive Shaft:
 - (1) PD = (2000) (.0127) + (2000) (.0127) = 50.8 vs. 53. Capability is OK
 - (2) PD = (1500) (.0085) = 12.7 vs. 53. Capability is OK.

B. Coupling between front and center sections:
 PD = (2000) (.0127) = 25.4 vs. 53. Capability is OK.

C. Coupling between center and rear sections:
 PD = (1500) (.0085) = 12.7 vs. 53. Capability is OK.

Note: For purpose of illustration, assume all three pump sections to be on pressure at the same time.
 A. Drive Shaft:
 PD = (2000) (.0127) + (2000) (.0127) + (1500) (.0085) = 63.5 vs. 53. Capability is not OK

Because the PD Factor for the shaft is 53, operating all three sections at the same time (to relief valve pressure) would exceed the torque capability of the drive shaft.

B. Coupling between front and center sections:
 PD = (2000) (.0127) + (1500) (.0085) = 35.1 vs. 53. Capability is OK

Remember also that the PD factor for the coupling is 53. If the center and rear sections are on pressure at the same time, the coupling between the front and center sections must transmit the torque for the center and rear sections.

**Specifications
for PVP16 Series**

Description Priority Valve Gear Pumps
Pump Flow Range To 38 GPM (143.8 LTR.)
Priority Flow Range 2 to 10 GPM Standard (7.6 to 37.8 LTR.)
Displacements To 3.904 C.I.R. (63.94 CC's/REV.)
Maximum Pressure to 3000 PSI (207 BAR)
Maximum Speed to 3600 RPM
Rotation A or C
Bearings Journal
Construction Cast Iron Gear Plate with
Aluminum Flange and Cover (Valve) Plate

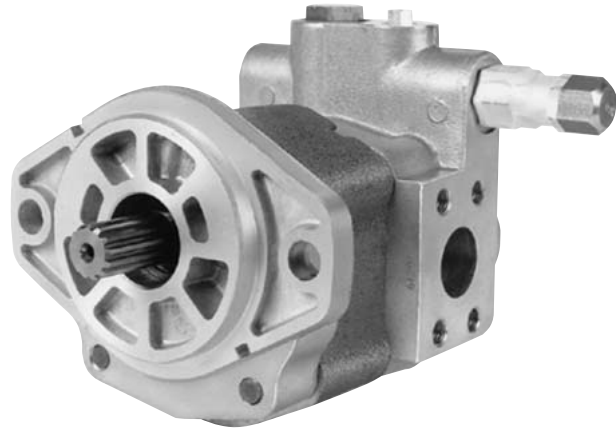

Performance Data

Pump Model	Section Size	Displacement/Revolution (Theoretical)					Maximum Pressure		Maximum Speed
		US Gallons	Cubic Inches	Liters	Cubic Centimeters	Imperial Gallons	PSI	BAR	RPM
PVP16	45	.0038	.878	.0144	14.388	.0031	3000	207	3600
PVP16	65	.0055	1.270	.0208	20.812	.0045	3000	207	3600
PVP16	85	.0072	1.663	.0273	27.252	.0060	3000	207	3400
PVP16	100	.0085	1.964	.0321	32.184	.0070	3000	207	3300
PVP16	115	.0097	2.241	.0367	36.723	.0080	3000	207	3100
PVP16	150	.0127	2.934	.0481	48.080	.0105	3000	207	2800
PVP16	180	.0152	3.511	.0575	57.535	.0125	2200	152	2500
PVP16	200	.0169	3.904	.0639	63.942	.0140	2000	138	2500

All data based on SAE 10W oil at 150°F.
Available with Viton® Seals.

CAUTION: "Inlet vacuum" should not exceed 5" Hg at normal operating speed and temperature.
Operation of pumps in excess of 5" Hg requires factory approval.

Priority Flow

CAT. NO 1	CAT. NO 2	CAT. NO 3	CAT. NO 4	CAT. NO 5	CAT. NO 6	CAT. NO 7	CAT. NO 8	CAT. NO 9
1 to 3 GPM	2 to 3 GPM	3 to 4 GPM	4 to 5 GPM	5 to 6 GPM	6 to 7 GPM	7 to 8 GPM	8 to 9 GPM	9 to 10 GPM
3.8 to 7.6 LPM	7.6 to 11.4 LPM	11.4 to 15.1 LPM	15.1 to 18.9 LPM	18.9 to 22.7 LPM	22.7 to 26.5 LPM	26.5 to 30.3 LPM	30.3 to 34.0 LPM	34.0 to 37.8 LPM

Consult factory for priority flow over 10 GPM.

Dimensional Data

Pump Models	Flange Type									Shipping Weights (Approx.)	
	D			E&J			F				
	A	B	C	A	B	C	A	B	C	lbs.	kgs.
PVP16 - 45	96.2 (3.79)	116.8 (4.60)	150.3 (5.92)	124.9 (4.92)	145.5 (5.73)	179.0 (7.05)	99.5 (3.92)	120.1 (4.73)	153.6 (6.05)	13	5.9
PVP16 - 65	101.6 (4.00)	122.1 (4.81)	155.7 (6.13)	130.3 (5.13)	150.8 (5.94)	184.4 (7.26)	104.9 (4.13)	125.4 (4.94)	159.0 (6.26)	14	6.4
PVP16 - 85	107.1 (4.22)	127.7 (5.03)	161.2 (6.35)	135.8 (5.35)	156.4 (6.16)	189.9 (7.48)	110.4 (4.35)	131.0 (5.16)	164.5 (6.48)	15	6.8
PVP16 - 100	111.2 (4.38)	131.8 (5.19)	165.3 (6.51)	139.9 (5.51)	160.5 (6.32)	194.0 (7.64)	114.5 (4.51)	135.1 (5.32)	168.6 (6.64)	16	7.3
PVP16 - 115	115.3 (4.54)	135.8 (5.35)	169.4 (6.67)	144.0 (5.67)	164.5 (6.48)	198.1 (7.80)	118.6 (4.67)	139.1 (5.48)	172.7 (6.80)	17	7.7
PVP16 - 150	124.7 (4.91)	145.2 (5.72)	178.8 (7.04)	153.4 (6.04)	173.9 (6.85)	207.5 (8.17)	128.0 (5.04)	148.5 (5.85)	182.1 (7.17)	18	8.2
PVP16 - 180	132.8 (5.23)	153.4 (6.04)	186.9 (7.36)	161.5 (6.36)	182.1 (7.17)	215.6 (8.49)	136.1 (5.36)	156.7 (6.17)	190.2 (7.49)	20	9.1
PVP16 - 200	138.1 (5.44)	158.7 (6.25)	192.2 (7.57)	166.8 (6.57)	187.4 (7.38)	220.9 (8.70)	144.4 (5.57)	162.0 (6.38)	195.5 (7.70)	21	9.5

Pump Models	Flange Type						Shipping Weights (Approx.)	
	N			S				
	A	B	C	A	B	C	lbs.	kgs.
PVP16 - 45	93.2 (3.67)	113.7 (4.48)	147.3 (5.80)	139.1 (5.48)	159.7 (6.29)	193.2 (7.61)	13	5.9
PVP16 - 65	98.5 (3.88)	119.1 (4.69)	152.6 (6.01)	144.5 (5.69)	165.1 (6.50)	198.6 (7.82)	14	6.4
PVP16 - 85	104.1 (4.10)	124.7 (4.91)	158.2 (6.23)	150.1 (5.91)	170.6 (6.72)	204.2 (8.04)	15	6.8
PVP16 - 100	108.20 (4.26)	128.7 (5.07)	162.3 (6.39)	154.1 (6.07)	174.7 (6.88)	208.2 (8.20)	16	7.3
PVP16 - 115	112.2 (4.42)	132.8 (5.23)	166.3 (6.55)	158.2 (6.23)	178.8 (7.04)	212.3 (8.36)	17	7.7
PVP16 - 150	121.6 (4.79)	142.2 (5.60)	175.7 (6.92)	167.6 (6.60)	188.2 (7.41)	221.7 (8.73)	18	8.2
PVP16 - 180	129.7 (5.11)	150.3 (5.92)	183.8 (7.24)	175.7 (6.92)	196.3 (7.73)	229.8 (9.05)	20	9.1
PVP16 - 200	135.1 (5.32)	155.7 (6.13)	189.2 (7.45)	181.1 (7.13)	201.6 (7.94)	235.2 (9.26)	21	9.5

D Dimensions

Flange Type	Dimensions
D	6.3 (.250)
E	4.7 (.187)
F	
J	6.3 (.250)
N	9.5 (.375)
S	6.3 (.250)

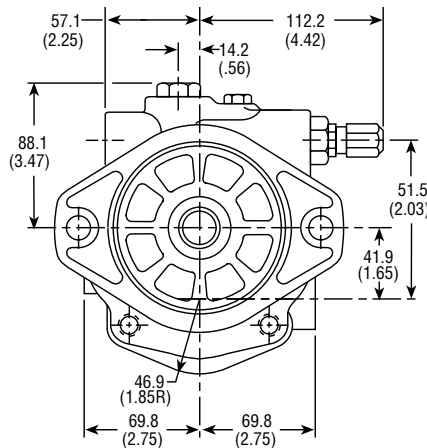
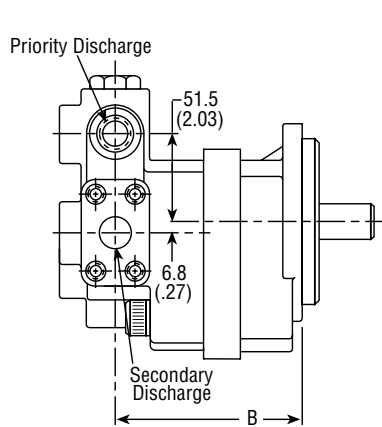

Drawn for Counterclockwise Rotation

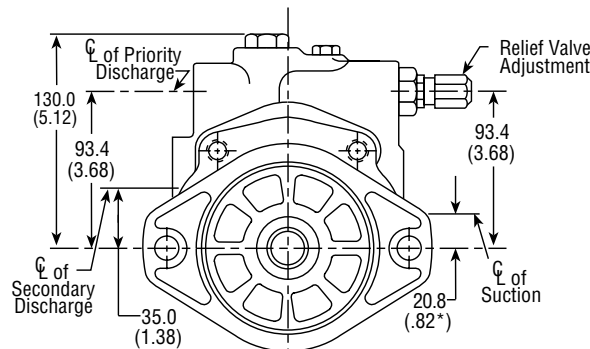
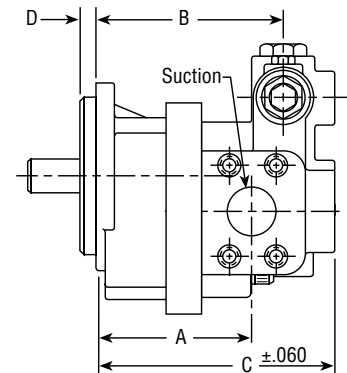

Drawn for Clockwise Rotation

Inch equivalents for millimeter dimensions are shown in (**).

**Specifications
for CP16 Series**

Description Clutch Pumps
Flow Range To 38 GPM (143.8 LTR)
Displacements To 3.904 C.I.R. (63.74 CC's/REV.)
Maximum Pressure to 3000 PSI (207 BAR)
Maximum Speed to 3600 RPM
Rotation A or C
Bearings Journal
Construction Cast Iron Gear Plates with
Aluminum Flange and Cover Plate



Performance Data

Pump Model	Section Size	US Gallons	Displacement/Revolution (Theoretical)				Maximum Pressure								Max. Speed RPM
											'V' Belt Drive				
			Clutch #1		Clutch #2						Clutch #3		Clutch #4		
			PSI	BAR	PSI	BAR	PSI	BAR	PSI	BAR	PSI	BAR	PSI	BAR	
P16	45	.0038	.878	.0144	14.39	.0031	3000	207	3000	207	3000	207	3000	207	3600
P16	65	.0055	1.270	.0208	20.83	.0045	3000	207	3000	207	3000	207	3000	207	3600
P16	85	.0072	1.663	.0273	27.27	.0060	2800	193	3000	207	3000	207	3000	207	3400
P16	100	.0085	1.964	.0321	32.21	.0070	2400	165	3000	207	3000	207	3000	207	3300
P16	115	.0097	2.241	.0367	36.75	.0080	2000	138	2900	200	3000	207	2900	200	3100
P16	150	.0127	2.934	.0481	48.11	.0105	1500	103	2600	179	3000	207	2600	179	2800
P16	180	.0152	3.511	.0575	57.57	.0125	1200	83	2100	145	2200	152	2100	145	2500
P16	200	.0169	3.904	.0639	63.94	.0140	1100	76	1900	131	2000	138	1900	131	2200

All data based on SAE 10W oil at 150°F.
Available with Viton® Seals.

CAUTION: "Inlet vacuum" should not exceed 5" Hg at normal operating speed and temperature.
Operation of pumps in excess of 5" Hg requires factory approval.

Operating Notes

- Detailed installation and operating instructions are included in each clutch-pump package. Consult those instructions before installation and/or operation.
- Clutch Data:
 - Clutch No. 1 - 12 V.D.C.; 4.26 amps; 2.82 ohms @ 20°C; 75 Lb. Ft.
 - Clutch No. 2 - 12 V.D.C.; 4.36 amps; 2.75 ohms @ 20°C; 125 Lb. Ft.
 - Clutch No. 3 - 12 V.D.C.; 4.58 amps; 2.62 ohms @ 20°C; 200 Lb. Ft.
 - Clutch No. 4 - 12 V.D.C.; 4.36 amps; 2.75 ohms @ 20°C; 125 Lb. Ft.
- Burnishing: If full rated torque (or system pressure) is required at start-up, burnishing or cycling of the clutch will be necessary. Burnishing of the clutch can be accomplished by running the engine between 2500 and 3000 RPM and cycling the clutch on and off against the system relief valve. The relief valve should be set at 75% of the maximum pressure rating as shown in the chart above. The clutch should be cycled 50 times at a rate of 10 to 15 cycles per minute.
- Voltage: The torque capability of the clutch varies with the actual voltage measured at the clutch. Do not operate at less than 11.5 volts.
- For maximum clutch life: #1 #2 & #4 should be mounted to run in 'C' rotation. #3 should be mounted to run in 'A' rotation, (looking at the front of the clutch).

Electric Clutch Switch: Order Kit No. 33520

Dimensional Data

Pump Models			With Clutch #1			With Clutch #2		
	A	B	C	D	E	C	D	E
P16-45	64.3 (2.53)	89.9 (3.54)	61.2 (2.41)	100.6 (3.96)	155.5 (6.12)	60.5 (2.38)	103.4 (4.07)	170.4 (6.71)
P16-65	69.6 (2.74)	95.3 (3.75)	61.2 (2.41)	100.6 (3.96)	155.5 (6.12)	60.5 (2.38)	103.4 (4.07)	170.4 (6.71)
P16-85	75.2 (2.96)	100.8 (3.97)	61.2 (2.41)	100.6 (3.96)	155.5 (6.12)	60.5 (2.38)	103.4 (4.07)	170.4 (6.71)
P16-100	79.3 (3.12)	104.9 (4.13)	61.2 (2.41)	100.6 (3.96)	155.5 (6.12)	60.5 (2.38)	103.4 (4.07)	170.4 (6.71)
P16-115	83.3 (3.28)	109.0 (4.29)	61.2 (2.41)	100.6 (3.96)	155.5 (6.12)	60.5 (2.38)	103.4 (4.07)	170.4 (6.71)
P16-150	92.7 (3.65)	118.4 (4.66)	61.2 (2.41)	100.6 (3.96)	155.5 (6.12)	60.5 (2.38)	103.4 (4.07)	170.4 (6.71)
P16-180	100.8 (3.97)	126.5 (4.98)	61.2 (2.41)	100.6 (3.96)	155.5 (6.12)	60.5 (2.38)	103.4 (4.07)	170.4 (6.71)
P16-200	106.2 (4.18)	131.8 (5.19)	61.2 (2.41)	100.6 (3.96)	155.5 (6.12)	60.5 (2.38)	103.4 (4.07)	170.4 (6.71)

Pump Models			With Clutch #4			Shipping Weights (Approx.)							
	A	B	C	D	E	Clutch #1		Clutch #2		Clutch #3		Clutch #4	
						lbs.	kgs.	lbs.	kgs.	lbs.	kgs.	lbs.	kgs.
P16-45	64.3 (2.53)	89.9 (3.54)	77.5 (3.05)	103.4 (4.07)	146.0 (5.75)	18.5	8.4	22.5	10.2	28.6	13.0	22.5	10.2
P16-65	69.6 (2.74)	95.3 (3.75)	77.5 (3.05)	103.4 (4.07)	146.0 (5.75)	19.5	8.8	23.5	10.7	29.6	13.4	23.5	10.7
P16-85	75.2 (2.96)	100.8 (3.97)	77.5 (3.05)	103.4 (4.07)	146.0 (5.75)	20.5	9.3	24.5	11.1	30.6	13.9	24.5	11.1
P16-100	79.3 (3.12)	104.9 (4.13)	77.5 (3.05)	103.4 (4.07)	146.0 (5.75)	21.5	9.8	25.5	11.6	31.6	14.3	25.5	11.6
P16-115	83.3 (3.28)	109.0 (4.29)	77.5 (3.05)	103.4 (4.07)	146.0 (5.75)	22.5	10.2	26.5	12.0	32.6	14.8	26.5	12.0
P16-150	92.7 (3.65)	118.4 (4.66)	77.5 (3.05)	103.4 (4.07)	146.0 (5.75)	23.5	10.7	27.5	12.5	33.6	15.2	27.5	12.5
P16-180	100.8 (3.97)	126.5 (4.98)	77.5 (3.05)	103.4 (4.07)	146.0 (5.75)	25.5	11.6	29.5	13.4	35.6	16.1	29.5	13.4
P16-200	106.2 (4.18)	131.8 (5.19)	77.5 (3.05)	103.4 (4.07)	146.0 (5.75)	26.5	12.0	30.5	13.8	36.6	16.6	30.5	13.8

Clutch No. 1 & 2
 'V' Belt Drive

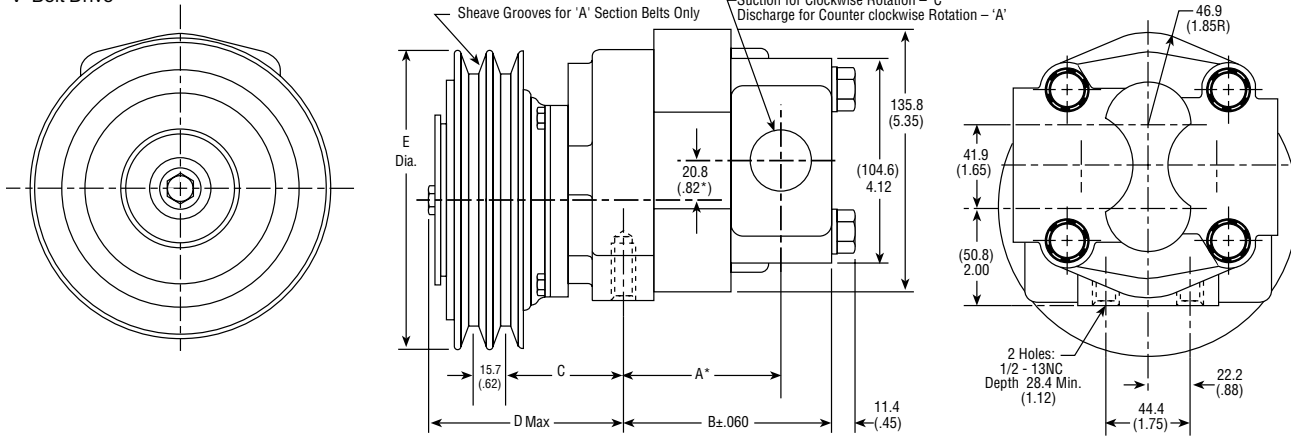

Clutch No. 3
 Direct Drive

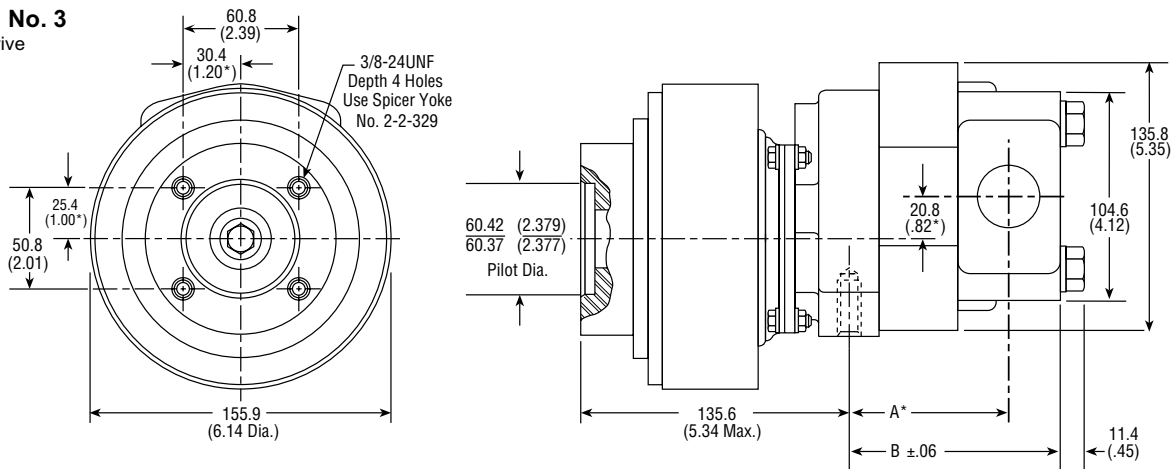

Inch equivalents for millimeter dimensions are shown in (**).

Shafts Available for P16 Series

Inch equivalents for millimeter dimensions are shown in (**).

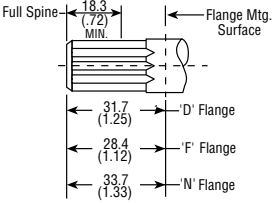
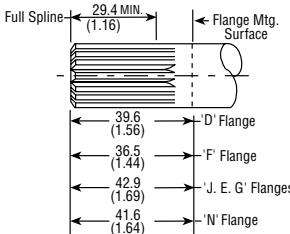
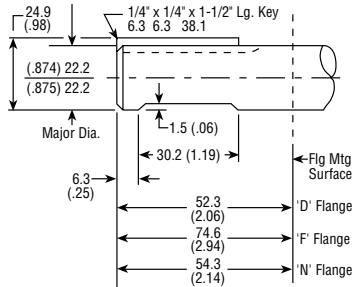
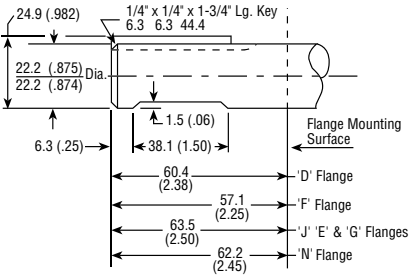
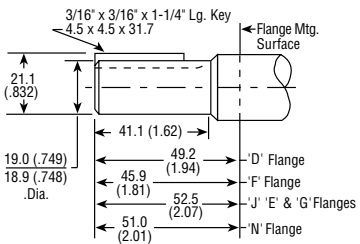
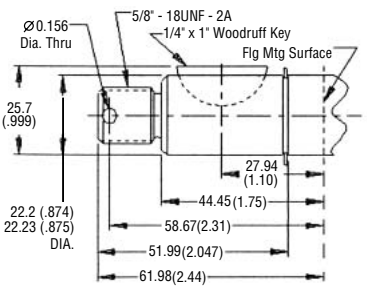
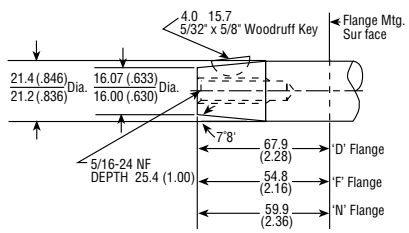
<p>1 5/8" Dia. 9 Tooth Spline Flat Root Side Fit Torque Limit 52 Lbs. Ft. (70.5 Nm) Available with 'D' 'F' & 'N' Flanges and in sizes P16-45 thru P16-100 only</p>  <p>Spline Data Diametral Pitch 16/32 Pressure Angle 30° No. Of Teeth 9</p>	<p>2 7/8" Dia. 13 Tooth Spline Flat Root Side Fit Torque Limit 184 Lbs. Ft. (249.4 Nm) Available in all sizes and flanges.</p>  <p>Spline Data Diametral Pitch 16/32 Pressure Angle 30° No. Of Teeth 13</p>	<p>3 7/8" Straight Shaft Torque Limit 184 Lbs. Ft. (249.4 Nm) Available in all sizes and D, F and N Flanges Only</p> 
<p>5 7/8" Straight Shaft Torque Limit 184 Lbs. Ft. (249.4 Nm) Available in all sizes and flanges.</p> 	<p>6 3/4" Straight Shaft Torque Limit 105 Lbs. Ft. (142.3 Nm) Available in sizes P16-45 thru P16-115 only and all flanges</p> 	<p>8 7/8" Straight Shaft Torque Limit 184 Lbs. Ft. (249.4 Nm) Available with N flange and sizes P16-65, P16-85 and P16-100 only.</p> 
<p>9 7/8" Tapered Shaft Torque Limit 184 Lbs. Ft. (249.4 Nm) Available in all sizes and D, F and N flanges only</p> 		

Clutch No.4
 Flat Ribbed Belt Drive

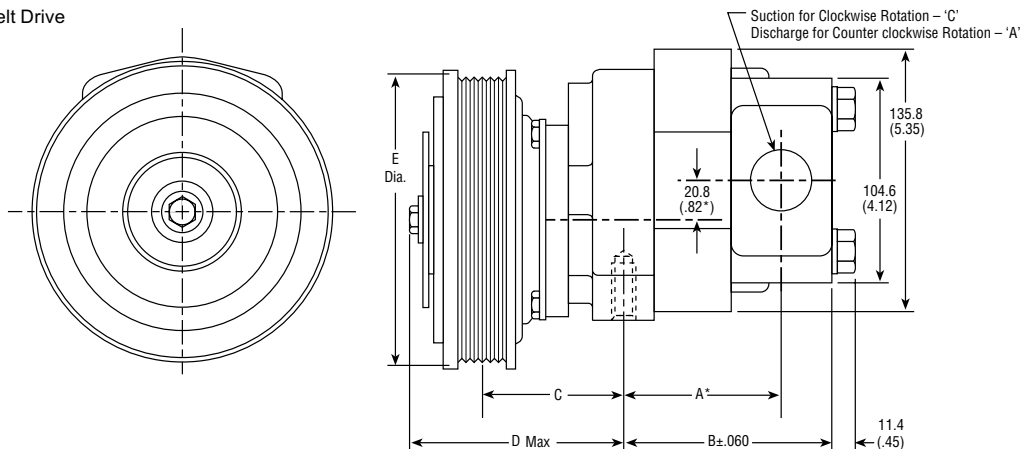

Mounting Flanges Available

Inch equivalents for millimeter dimensions are shown in (**).

<p>D SAE 'A' 2-Bolt</p>	<p>E 6-Bolt Round Available with No. 2, 5 or 6 Shafts Only</p>	<p>F Pad Mount</p>
<p>G SAE 'C' 4-Bolt Available for No. 2 or 5 Shaft Only</p>	<p>J SAE 'B' 4-Bolt Available for No. 2, 5 or 6 Shaft Only</p>	<p>N SAE 'B' 2-Bolt</p>
<p>S P.T.O. Direct Mount Available with No. 2 Shaft Only</p>	<p>T P.T.O. Direct Mount T19C Trans Available with No. 2 Shaft Only</p>	

Cover Plates Available for P16 / CP16

Inch equivalents for millimeter dimensions are shown in (**).

<p>1 Rear Ported Straight Thread</p>	<p>2 Rear Ported NPT</p> <p>7 Rear Ported BSPT</p>	<p>3 Side Ported SAE 4-Bolt Metric Threads are available – Consult factory. SAE 4-Bolt NPT Connectors Are Available. See Accessory Section.</p>
<p>4 Side Ported NPT</p> <p>8 Side Ported BSPT</p>	<p>5 Side Ported Straight Thread SAE 12 Discharge</p> <p>9 Side Ported Straight Thread SAE 16 Discharge</p>	<p>6 Rear Ported Straight Thread</p>
<p>10 Side Ported SAE 4-Bolt Rear Ported Straight Thread</p>	<p>11 Side Ported SAE 4-Bolt Straight Thread Must use 1-1/4" Length Max. Capscrews</p>	

Cover Plates Available for PVP16

Inch equivalents for millimeter dimensions are shown in (**).

3 Side Ported SAE 4-Bolt

SAE 8 3/4-16UNF-2B Priority Discharge
 3/8-16NC Depth 22.3 (.88)
 3/4" SAE 4-Bolt Conn. Secondary Discharge
 1 1/4" SAE 4-Bolt Conn. Suction
 7/16-14NC Depth 22.3 (.88)

47.6 (1.86)
 23.6 (.93)
 10.9 (.43)
 21.8 (.86)
 58.7 (2.31)
 29.2 (1.15*)
 14.9 (.59)
 30.1 (1.19)

SAE 4-Bolt NPT Connectors Are Available. See Accessory Section

5 Side Ported Straight Thread

SAE 8 3/4-16UNF-2B Priority Discharge
 SAE 10 7/8-14UNF-2B Secondary Discharge
 SAE 20 1-5/8-12UN-2B Suction

53.8 (2.12)
 32.2 (1.31)
 87.3 (3.44)

6 Rear Ported Straight Thread

14.2 (.56)
 35.0 (1.38)
 SAE 8 3/4-16UNF-2B Priority Discharge
 SAE 10 7/8-14UNF-2B Secondary Discharge
 SAE 20 1-5/8-12UN-2B Suction

20.8 (.82)
 51.5 (2.03)
 41.9 (1.65)
 6.8 (.27)
 70.8 (2.79)
 70.8 (2.79)
 C of Drive Shaft for Counterclockwise Rotation
 C of Drive Shaft for Clockwise Rotation
 C of Drive Shaft

SAE 20 1-5/8 12 UN-2B THREAD
 Suction Port Adapter
 Order Kit Number 15369
 SAE 16 1-5/16 12 UN-2B THREAD

Discharge Ports for Connector Plate and Cover Plate for TP16

3 SAE 4-Bolt
 Metric threads are available - Consult Factory. SAE 4-Bolt NPT Connectors Are Available. See Accessory Section

*3/8-16UNC Depth .88 22.3
 22.0 (.875)
 10.9 (.43)
 46.7 (1.87)
 23.3 (.93)
 3/4" SAE 4-Bolt Conn.

4 NPT-Pipe Thread
8 BSPT-Pipe Thread

3/4-14 PT

5 SAE 12 Straight Thread

1-1/16-12UN-2B

9 SAE 16 Straight Thread

1-5/16-12UN-2B

General Information for 20 Series

■ Standard Series - Available in various configurations:

- 20 — Single section
- TP20 — Tandem, 2 & 3 Place
- R20 — Reversible, 2 piece construction
- PB20 — Piggy-back design - allowing for additional pumps

■ Construction:

- Aluminum - For excellent power to weight ratio
or
- Cast iron - for extra durability.*

■ Journal bearings for long life
and good, over-hung load capability

■ Buna-N Seals are standard for petroleum and
glycol based fluids, "VitonE®" seals are optional.

■ Pressure balanced plates for greater efficiency

■ 20 Series with Integral Logic Valves / Tandem Pumps:

NST20 — Tandem pump with flow
sensitive unloading valve

NSD20 — Tandem pump with flow-sensitive unloading
valve and power-beyond port for the unloading valve

NSH20 — Tandem pump with
pressure-sensitive unloading valve

NDS20 — Tandem pump with
pressure-summation unloading valve

NSHD20 — Tandem pump with flow
and pressure-sensing unloading valve

PSH20 — Tandem pump with air-
operated unloading valve

Utilizing:

- Integral valving eliminates the need
for external valves and related plumbing

* Cast iron is not available on all models.
Consult factory for availability.

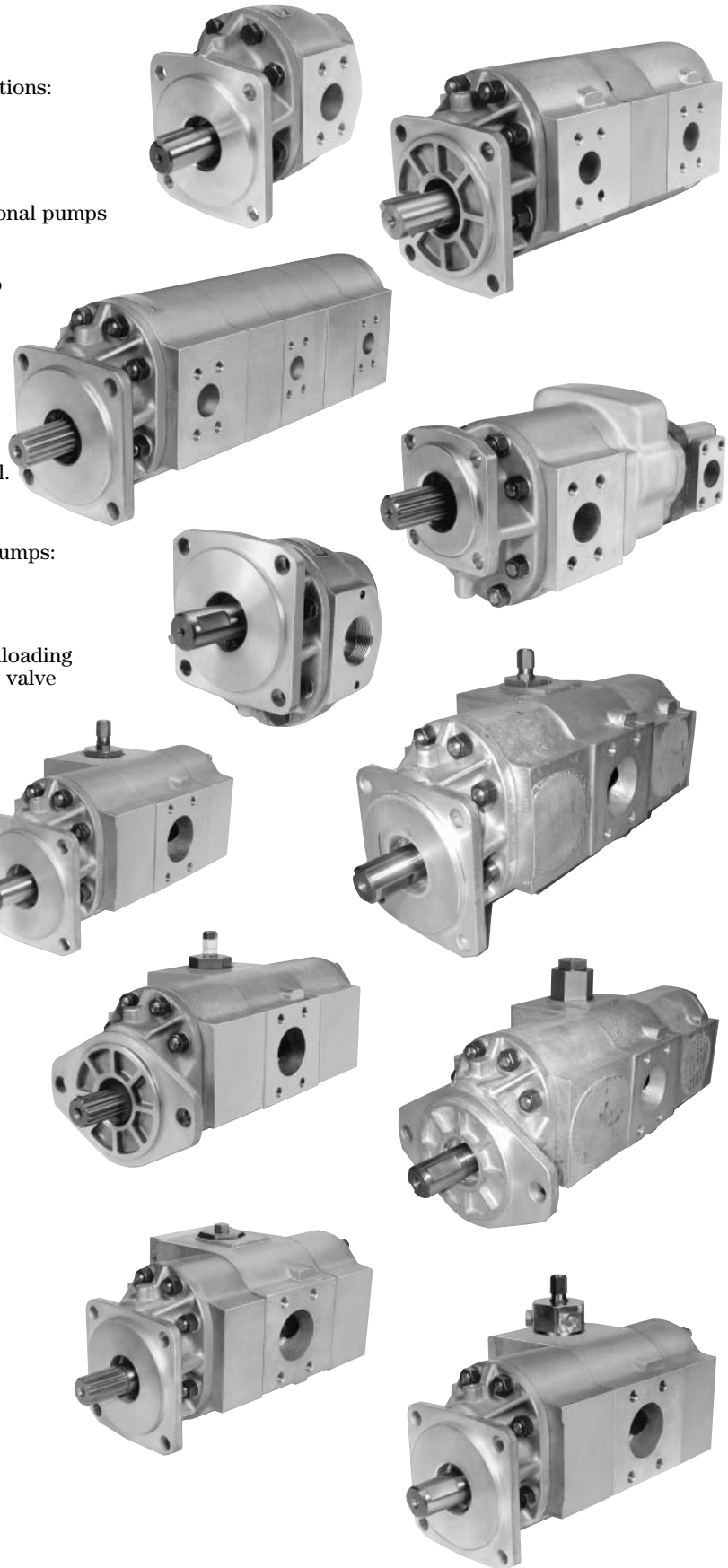

How to Order 20 Series:

Select the desired symbol (in the correct position) to construct a model code.

Assembly Example:

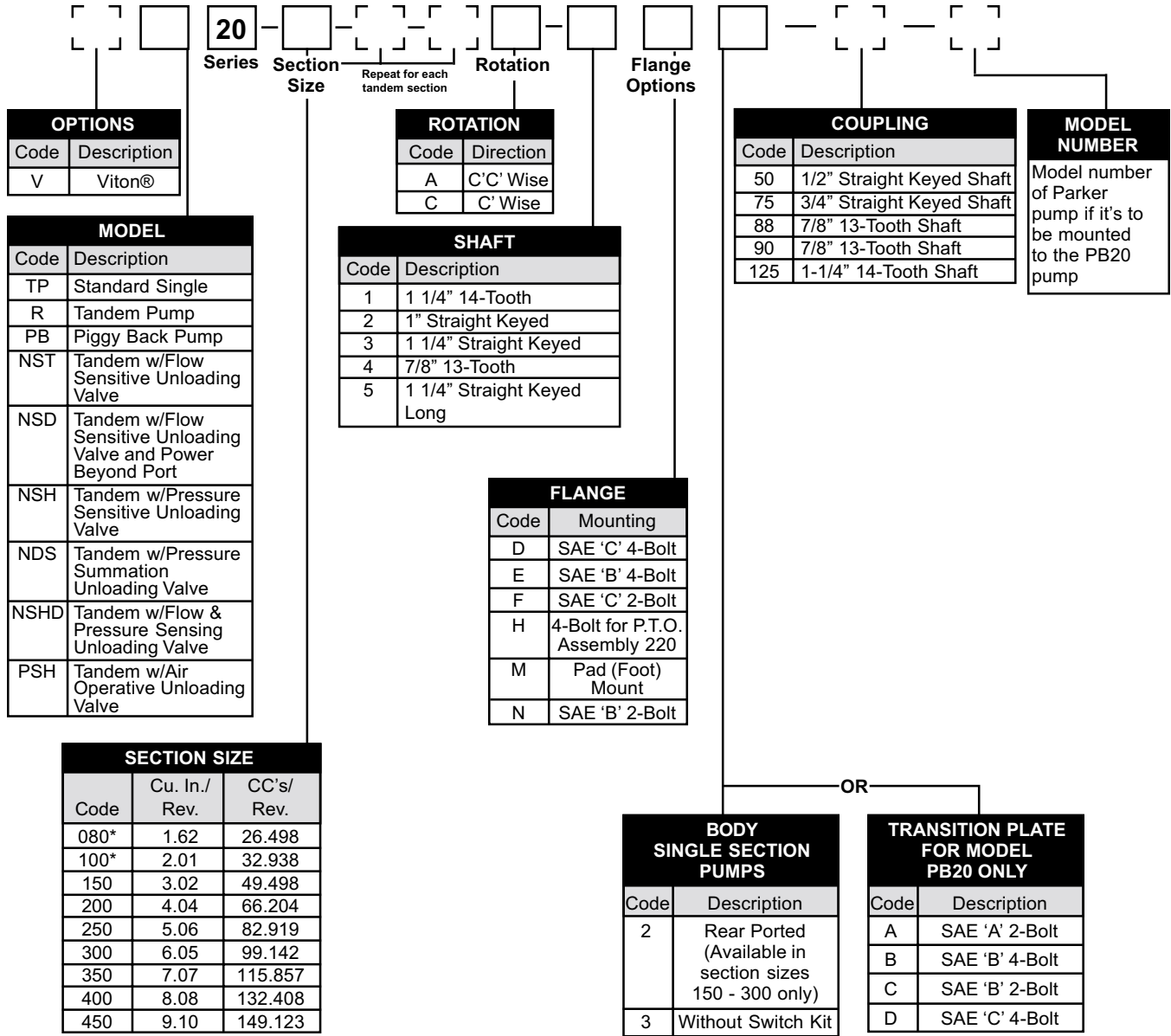

*Available as rear sections in tandem pumps only

Note: Add prefix 'V' to pump model number (V20) when ordering pumps with Viton® Seals.
 Cast Iron is available on some models.
 Consult factory for availability

**Specifications
for 20 Series**

Description Gear Pump
Flow Range To 98 GPM (370.9 LTR.)
Displacements To 9.10 C.I.R. (149.12 CC's/REV.)
Maximum Pressure to 2500 PSI (172 BAR)
Maximum Speed to 2500 RPM
Rotation A or C
Bearing Journal
Construction Aluminum or Cast Iron*

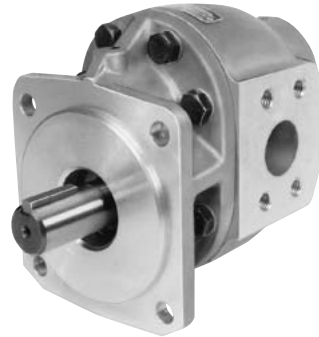

Performance Data

Pump Model	Section Size	Displacement/Revolution (Theoretical)					Maximum Pressure		Maximum Speed
		US Gallons	Cubic Inches	Liters	Cubic Centimeters	Imperial Gallons	PSI	BAR	RPM
20	150	.0131	3.02	.0496	49.498	.0108	2500	172	2500
20	200	.0175	4.04	.0662	66.204	.0146	2500	172	2500
20	250	.0219	5.06	.0829	82.919	.0182	2500	172	2500
20	300	.0262	6.05	.0992	99.142	.0218	2500 ⁽¹⁾	172	2500
20	350	.0306	7.07	.1158	115.857	.0255	2500 ⁽²⁾	172	2500
20	400	.0350	8.08	.1325	132.408	.0292	2500	172	2500
20	450	.0394	9.10	.1491	149.123	.0328	2500	172	2500

Notes: (1) 2100 PSI maximum due to torque limitations of No. 4 shaft. (2) 1800 PSI maximum due to torque limitations of No. 4 shaft
All data based on SAE 10W oil at 150°F. Available with Viton® Seals.

*Some models and sizes are available for pressure up to 3500 PSI. Cast-iron not available on all models. Consult factory for availability.



CAUTION: "Inlet vacuum" should not exceed 5" Hg at normal operating speed and temperature.
Operation of pumps in excess of 5" Hg requires factory approval.

Dimensional Data

SAE 4-Bolt Connector Ports					
Size	C	D	E	F	G
1"	12.9 (.51)	26.1 (1.031)	26.1 (1.03)	52.3 (2.062)	3/8-16NC
1-1/4"	14.9 (.59)	30.1 (1.188)	29.2 (1.15)	58.7 (2.313)	7/16-14NC
1-1/2"	17.7 (.70)	35.7 (1.406)	34.7 (1.37)	69.8 (2.750)	1/2-13NC
2"	21.3 (.84)	42.8 (1.688)	38.8 (1.53)	77.7 (3.062)	1/2-13NC

Bodies Available

Inch equivalents for millimeter dimensions are shown in (**).

2

Mounting Dimensions								
PUMP MODEL	For B & C 4-Bolt & B & C 2-Bolt Flanges A		SAE 4-Bolt Connector Ports				Shipping Weights	
			Inlet		Outlet			
			Conn. Sz.	Hole Dia.	Conn. Sz.	Hole Dia.	lbs.	kgs.
20150	167.8 (6.61)		1-1/4"	30.2 (1.19)	1"	23.8 (.937)	19	8.62
20200	167.8 (6.61)		1-1/2"	38.1 (1.50)	1-1/4"	30.2 (1.19)	21	9.53
20250	167.8 (6.61)		1-1/2"	38.1 (1.50)	1-1/4"	30.2 (1.19)	22	9.98
20300	174.2 (6.86)		1-1/2"	38.1 (1.50)	1-1/4"	30.2 (1.19)	23	10.04

3

Mounting Dimensions								
PUMP MODEL	For B & C 4-Bolt & B & C 2-Bolt Flanges A B		SAE 4-Bolt Connector Ports				Shipping Weights	
			Inlet		Outlet			
			Conn. Sz.	Hole Dia.	Conn. Sz.	Hole Dia.	lbs.	kgs.
20150	104.6 (4.12)	167.8 (6.61)	1-1/4"	30.2 (1.19)	1"	23.8 (.937)	19	8.62
20200	104.6 (4.12)	167.8 (6.61)	1-1/4"	30.2 (1.19)	1"	23.8 (.937)	20	9.07
20250	104.6 (4.12)	167.8 (6.61)	1-1/2"	38.1 (1.50)	1-1/4"	30.2 (1.19)	21	9.53
20300	104.6 (4.12)	175.2 (6.90)	1-1/2"	38.1 (1.50)	1-1/4"	30.2 (1.19)	22	9.98
20350	110.4 (4.35)	182.3 (7.18)	1-1/2"	38.1 (1.50)	1-1/4"	30.2 (1.19)	23	10.4
20400	110.4 (4.35)	189.7 (7.47)	2"	50.8 (2.00)	1-1/4"	34.7 (1.37)	24	10.9
20450	118.3 (4.66)	196.8 (7.75)	2"	50.8 (2.00)	1-1/4"	34.7 (1.37)	25	11.3

**Specifications
 for TP20 Series**

Description Gear Pumps (Two-place)
 Flow Range To 98 GPM Per Section (370.9 LTR.)
 Displacements To 9.10 C.I.R. Per Section (149.12 CC's/REV.)
 Maximum Pressure to 2500 PSI (172 BAR)
 Maximum Speed to 2500 RPM
 Rotation A or C
 Bearing Journal
 Construction Aluminum or Cast Iron*

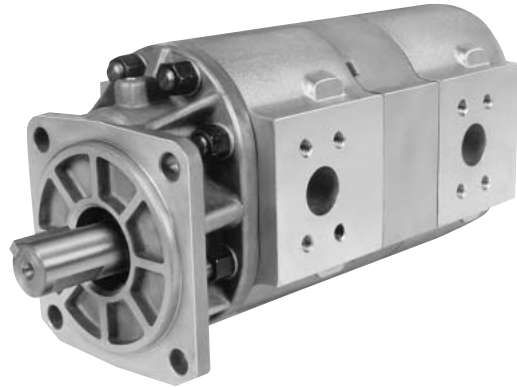

Performance Data Per Section

Pump Model	Section Size	Displacement/Revolution (Theoretical)					Maximum Pressure		Maximum Speed
		US Gallons	Cubic Inches	Liters	Cubic Centimeters	Imperial Gallons	PSI	BAR	RPM
TP20	080**	.0070	1.62	.0265	26.498	.0058	2500	172	2500
TP20	100**	.0087	2.01	.0330	32.938	.0072	2500	172	2500
TP20	150	.0131	3.02	.0496	49.498	.0108	2500	172	2500
TP20	200	.0175	4.04	.0662	66.204	.0146	2500	172	2500
TP20	250	.0219	5.06	.0829	82.919	.0182	2500	172	2500
TP20	300	.0262	6.05	.0992	99.142	.0218	2500	172	2500
TP20	350	.0306	7.07	.1158	115.857	.0255	2500	172	2500
TP20	400	.0350	8.08	.1325	132.408	.0292	2500	172	2500
TP20	450	.0394	9.10	.1491	149.123	.0328	2500	172	2500

All data based on SAE 10W oil at 150°F. Available with Viton® Seals.
 *Some models and sizes are available for pressure up to 3500 PSI. Cast-iron not available on all models. Consult factory for availability.



CAUTION: "Inlet vacuum" should not exceed 5" Hg at normal operating speed and temperature. Operation of pumps in excess of 5" Hg requires factory approval.

**080 and 100 Sizes Available for Rear Sections Only.

Dimensional Data

Pump Sizes	Port Sizes						Mounting Dimensions			
	Common Suction		Discharge Front		Discharge Rear					
	Hole Dia.	Conn. Size	Hole Dia.	Conn. Size	Hole Dia.	Conn. Size	A	B	C	J
TP20150-080	38.1 (1.50)	1 1/2	19.0 (.75)	3/4	19.0 (.75)	3/4	91.4 (3.60)	198.8 (7.83)	239.7 (9.44)	95.2 (3.75)
TP20150-100	38.1 (1.50)	1 1/2	19.0 (.75)	3/4	19.0 (.75)	3/4	91.4 (3.60)	201.4 (7.93)	242.8 (9.56)	95.2 (3.75)
TP20150-150	38.1 (1.50)	1 1/2	19.0 (.75)	3/4	19.0 (.75)	3/4	91.4 (3.60)	201.4 (7.93)	250.1 (9.85)	95.2 (3.75)
TP20200-080	38.1 (1.50)	1 1/2	25.4 (1.00)	1	19.0 (.75)	3/4	95.2 (3.75)	222.5 (8.76)	263.6 (10.38)	98.0 (3.86)
TP20200-100	38.1 (1.50)	1 1/2	25.4 (1.00)	1	19.0 (.75)	3/4	95.2 (3.75)	225.0 (8.86)	266.7 (10.50)	98.0 (3.86)
TP20200-150	50.8 (2.00)	2	25.4 (1.00)	1	19.0 (.75)	3/4	95.2 (3.75)	225.0 (8.86)	274.0 (10.79)	98.0 (3.86)
TP20200-200	50.8 (2.00)	2	25.4 (1.00)	1	25.4 (1.00)	1	95.2 (3.75)	241.3 (9.50)	307.8 (12.12)	98.0 (3.86)
TP20250-080	50.8 (2.00)	2	30.2 (1.19)	1 1/4	19.0 (.75)	3/4	101.6 (4.00)	229.8 (9.05)	271.0 (10.67)	101.6 (4.00)
TP20250-100	50.8 (2.00)	2	30.2 (1.19)	1 1/4	19.0 (.75)	3/4	101.6 (4.00)	232.4 (9.15)	274.0 (10.79)	101.6 (4.00)
TP20250-150	50.8 (2.00)	2	30.2 (1.19)	1 1/4	19.0 (.75)	3/4	101.6 (4.00)	232.4 (9.15)	281.1 (11.07)	101.6 (4.00)
TP20250-200	50.8 (2.00)	2	30.2 (1.19)	1 1/4	25.4 (1.00)	1	101.6 (4.00)	248.6 (9.79)	315.2 (12.41)	101.6 (4.00)
TP20250-250	50.8 (2.00)	2	30.2 (1.19)	1 1/4	34.7 (1.25)	1 1/4	101.6 (4.00)	255.0 (10.04)	325.1 (12.80)	101.6 (4.00)
TP20300-080	50.8 (2.00)	2	30.2 (1.19)	1 1/4	19.0 (.75)	3/4	105.1 (4.14)	236.7 (9.32)	278.1 (10.95)	105.1 (4.14)
TP20300-100	50.8 (2.00)	2	30.2 (1.19)	1 1/4	19.0 (.75)	3/4	105.1 (4.14)	239.2 (9.42)	281.1 (11.07)	105.1 (4.14)
TP20300-150	50.8 (2.00)	2	30.2 (1.19)	1 1/4	19.0 (.75)	3/4	105.1 (4.14)	239.2 (9.42)	288.0 (11.34)	105.1 (4.14)
TP20300-200	50.8 (2.00)	2	30.2 (1.19)	1 1/4	25.4 (1.00)	1	105.1 (4.14)	255.7 (10.07)	322.3 (12.69)	105.1 (4.14)
TP20300-250	50.8 (2.00)	2	30.2 (1.19)	1 1/4	34.7 (1.25)	1 1/4	105.1 (4.14)	262.1 (10.32)	332.4 (13.09)	105.1 (4.14)
TP20300-300	63.5 (2.50)	2 1/2	30.2 (1.19)	1 1/4	30.2 (1.19)	1 1/4	105.1 (4.14)	262.1 (10.32)	339.5 (13.37)	105.1 (4.14)
TP20350-080	63.5 (2.50)	2 1/2	30.2 (1.19)	1 1/4	19.0 (.75)	3/4	110.4 (4.35)	244.3 (9.62)	285.4 (11.24)	110.2 (4.34)
TP20350-100	63.5 (2.50)	2 1/2	30.2 (1.19)	1 1/4	19.0 (.75)	3/4	110.4 (4.35)	246.8 (9.72)	288.5 (11.36)	110.2 (4.34)
TP20350-150	63.5 (2.50)	2 1/2	30.2 (1.19)	1 1/4	19.0 (.75)	3/4	110.4 (4.35)	246.8 (9.72)	295.6 (11.64)	110.2 (4.34)
TP20350-200	63.5 (2.50)	2 1/2	30.2 (1.19)	1 1/4	25.4 (1.00)	1	110.4 (4.35)	262.8 (10.35)	329.6 (12.98)	110.2 (4.34)
TP20350-250	63.5 (2.50)	2 1/2	30.2 (1.19)	1 1/4	34.7 (1.25)	1 1/4	110.4 (4.35)	269.2 (10.60)	339.5 (13.37)	110.2 (4.34)
TP20350-300	63.5 (2.50)	2 1/2	30.2 (1.19)	1 1/4	30.2 (1.19)	1 1/4	110.4 (4.35)	269.2 (10.60)	346.9 (13.66)	110.2 (4.34)
TP20400-080	61.7 (2.43)	2 1/2	34.7 (1.37)	1 1/2	19.0 (.75)	3/4	110.4 (4.35)	251.4 (9.90)	292.6 (11.52)	110.2 (4.34)
TP20400-100	61.7 (2.43)	2 1/2	34.7 (1.37)	1 1/2	19.0 (.75)	3/4	110.4 (4.35)	254.0 (10.00)	295.6 (11.64)	110.2 (4.34)
TP20400-150	61.7 (2.43)	2 1/2	34.7 (1.37)	1 1/2	19.0 (.75)	3/4	110.4 (4.35)	254.0 (10.00)	302.7 (11.92)	110.2 (4.34)
TP20400-200	61.7 (2.43)	2 1/2	34.7 (1.37)	1 1/2	25.4 (1.00)	1	110.4 (4.35)	270.2 (10.64)	336.8 (13.26)	110.2 (4.34)
TP20400-250	61.7 (2.43)	2 1/2	34.7 (1.37)	1 1/2	34.7 (1.25)	1 1/4	110.4 (4.35)	276.6 (10.89)	346.9 (13.66)	110.2 (4.34)
TP20400-300	61.7 (2.43)	2 1/2	34.7 (1.37)	1 1/2	30.2 (1.19)	1 1/4	110.4 (4.35)	276.6 (10.89)	354.0 (13.94)	110.2 (4.34)
TP20450-080	61.7 (2.43)	2 1/2	34.7 (1.37)	1 1/2	19.0 (.75)	3/4	118.3 (4.66)	258.5 (10.18)	299.7 (11.80)	110.2 (4.34)
TP20450-100	61.7 (2.43)	2 1/2	34.7 (1.37)	1 1/2	19.0 (.75)	3/4	118.3 (4.66)	261.1 (10.28)	302.7 (11.92)	110.2 (4.34)
TP20450-150	61.7 (2.43)	2 1/2	34.7 (1.37)	1 1/2	19.0 (.75)	3/4	118.3 (4.66)	261.1 (10.28)	309.8 (12.20)	110.2 (4.34)
TP20450-200	61.7 (2.43)	2 1/2	34.7 (1.37)	1 1/2	25.4 (1.00)	1	118.3 (4.66)	277.3 (10.92)	343.9 (13.54)	110.2 (4.34)
TP20450-250	61.7 (2.43)	2 1/2	34.7 (1.37)	1 1/2	34.7 (1.25)	1 1/4	118.3 (4.66)	283.7 (11.17)	354.0 (13.94)	110.2 (4.34)
TP20450-300	61.7 (2.43)	2 1/2	34.7 (1.37)	1 1/2	30.2 (1.19)	1 1/4	118.3 (4.66)	283.7 (11.17)	361.1 (14.22)	110.2 (4.34)

Dimensional Data

SAE 4-Bolt Connector Ports					
Size	D	E	F	G	H
3/4"	10.9 (.43)	22.2 (.875)	23.6 (.93)	47.6 (1.875)	3/8-16NC
1"	12.9 (.51)	26.1 (1.031)	26.1 (1.03)	52.3 (2.062)	3/8-16NC
1-1/4"	14.9 (.59)	30.1 (1.188)	29.2 (1.15)	58.7 (2.313)	7/16-14NC
1-1/2"	17.9 (.70)	35.7 (1.406)	34.7 (1.37)	69.8 (2.750)	1/2-13NC
2"	21.3 (.84)	42.8 (1.688)	38.8 (1.53)	77.7 (3.062)	1/2-13NC
2-1/2"	25.4 (1.00)	50.8 (2.000)	44.4 (1.75)	88.9 (3.500)	1/2-13NC

SAE 4-Bolt NPT Connectors are available. See Accessory Section.

PD Factors

Drive Shaft	Factors
#1 - 1/4 Spline	187
#3 - 1/4 Keyed	187
#5 - 1/4 Keyed	187
Coupling	110

The maximum size and number of sections of a tandem pump for a given application is limited to the torque capability of the input drive shaft and the spline coupling between the sections. To determine this capability, a "PD Factor" is used:

- P = PSI (The relief setting of each individual section).
- D = Displacement (In U.S. gallon per revolution of each section).

Example: Assume a double pump TP20450-450A-3D with front and rear sections on pressure at the same time at 2500 PSI.

- A. Drive Shaft:
 $PD = (2500) (.0394) + (2500) (.0394) = 197$ vs. 187.
 Capability of drive shaft is not OK.
- B. Coupling between front and rear sections:
 $PD = (2500) (.0394) = 98.5$ vs. 110.
 Capability of coupling is OK.

NOTE: If the rear section of this tandem pump was limited to 2000 PSI, the combination of both sections would be acceptable:

$PD = (2500) (.0394) + (2000) (.0394) = 177.3$ vs. 187.
 Capability of drive shaft is OK.

Inch equivalents for millimeter dimensions are shown in (**).

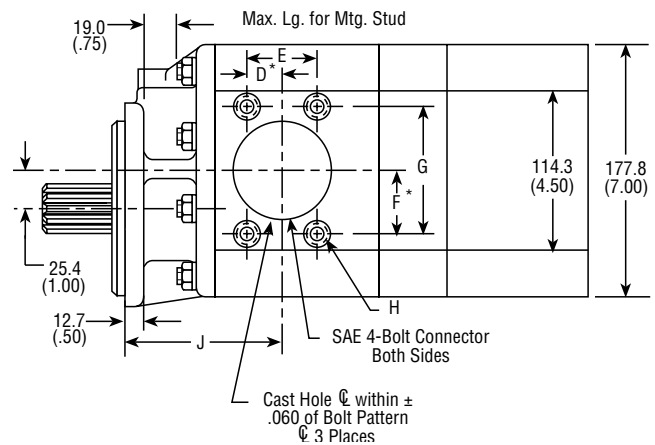
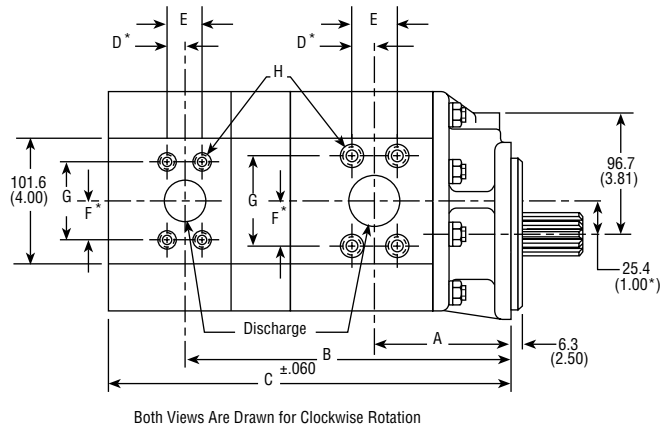
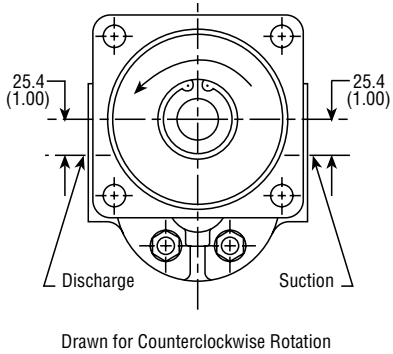
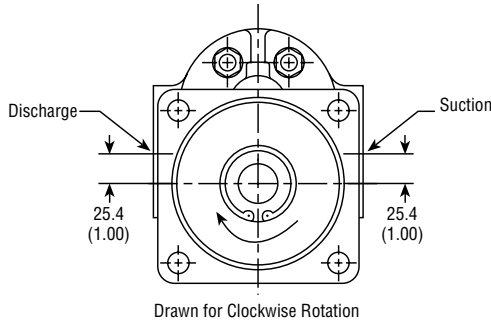

**Specifications
 for TP20 Series**

Description Gear Pump (Three-place)
 Flow Range To 98 GPM Per Section (370.9 LTR.)
 Displacements To 9.10 C.I.R. Per Section (149.12 CC's/REV.)
 Maximum Pressure to 2500 PSI (172 BAR)
 Maximum Speed to 2500 RPM
 Rotation A or C
 Bearing Journal
 Construction Aluminum or Cast Iron*

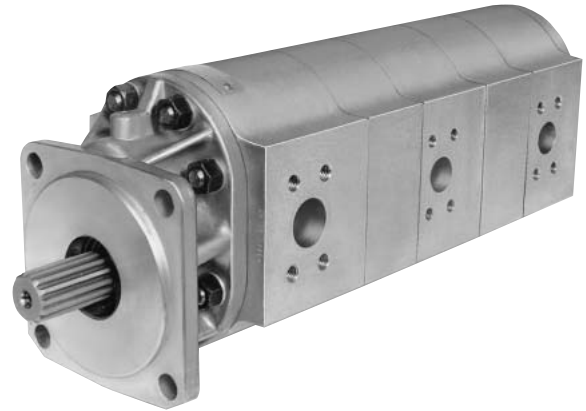

Performance Data Per Section

Pump Model	Section Size	Displacement/Revolution (Theoretical)					Maximum Pressure		Maximum Speed
		US Gallons	Cubic Inches	Liters	Cubic Centimeters	Imperial Gallons	PSI	BAR	RPM
TP20	100**	.0087	2.01	.0330	32.938	.0072	2500	172	2500
TP20	150	.0131	3.02	.0496	49.498	.0108	2500	172	2500
TP20	200	.0175	4.04	.0662	66.204	.0146	2500	172	2500
TP20	250	.0219	5.06	.0829	82.919	.0182	2500	172	2500
TP20	300	.0262	6.05	.0992	99.142	.0218	2500	172	2500
TP20	350	.0306	7.07	.1158	115.857	.0255	2500	172	2500
TP20	400	.0350	8.08	.1325	132.408	.0292	2500	172	2500
TP20	450	.0394	9.10	.1491	149.123	.0328	2500	172	2500

All data based on SAE 10W oil at 150°F.
 Available with Viton® Seals.

*Some models and sizes are available for pressure up to 3500 PSI. Cast-iron not available on all models. Consult factory for availability.



CAUTION: "Inlet vacuum" should not exceed 5" Hg at normal operating speed and temperature. Operation of pumps in excess of 5" Hg requires factory approval.

**100 Sizes Available for Rear Sections Only.

Dimensional Data

Front Section Suction & Discharge Ports						
Front Section	Hole Dia.	Suction	Hole Dia.	Disc.	E	F
20150	31.7 (1.25)	1-1/4"	19.0 (.75)	3/4"	91.4 (3.60)	123.6 (4.87)
20200	31.7 (1.25)	1-1/4"	25.4 (1.00)	1"	95.2 (3.75)	147.5 (5.81)
20250	38.1 (1.50)	1-1/2"	30.2 (1.19)	1-1/4"	101.6 (4.00)	154.6 (6.09)
20300	38.1 (1.50)	1-1/2"	30.2 (1.19)	1-1/4"	105.1 (4.14)	161.7 (6.37)
20350	38.1 (1.50)	1-1/2"	30.2 (1.19)	1-1/4"	110.4 (4.35)	169.1 (6.66)
20400	50.8 (2.00)	2"	34.7 (1.37)	1-1/2"	110.4 (4.35)	176.2 (6.94)
20450	50.8 (2.00)	2"	34.7 (1.37)	1-1/2"	118.3 (4.66)	183.6 (7.23)

Center and Rear Section Suction Ports						
Section Ctr-Rear	Hole Dia.	Common Suction	A	B	C	D
100-100	31.7 (1.25)	1-1/4"	77.4 (3.05)	181.1 (7.13)	222.7 (8.77)	77.4 (3.05)
150-100	38.1 (1.50)	1-1/2"	77.4 (3.05)	187.1 (7.37)	228.8 (9.01)	81.2 (3.20)
150-150	38.1 (1.50)	1-1/2"	77.4 (3.05)	187.1 (7.37)	235.9 (9.29)	81.2 (3.20)
200-100	38.1 (1.50)	1-1/2"	93.7 (3.69)	223.5 (8.80)	265.1 (10.44)	96.5 (3.80)
200-150	50.8 (2.00)	2"	93.7 (3.69)	223.5 (8.80)	272.2 (10.72)	96.5 (3.80)
200-200	50.8 (2.00)	2"	93.7 (3.69)	239.7 (9.44)	306.3 (12.06)	96.5 (3.80)
250-100	50.8 (2.00)	2"	100.0 (3.94)	230.6 (9.08)	272.2 (10.72)	100.0 (3.94)
250-150	50.8 (2.00)	2"	100.0 (3.94)	230.6 (9.08)	279.4 (11.00)	100.0 (3.94)
250-200	50.8 (2.00)	2"	100.0 (3.94)	246.8 (9.72)	313.4 (12.34)	100.0 (3.94)
250-250	50.8 (2.00)	2"	100.0 (3.94)	253.2 (9.97)	323.5 (12.74)	100.0 (3.94)
300-100	50.8 (2.00)	2"	103.6 (4.08)	237.9 (9.37)	279.4 (11.00)	103.6 (4.08)
300-150	50.8 (2.00)	2"	103.6 (4.08)	237.9 (9.37)	286.7 (11.29)	103.6 (4.08)
300-200	50.8 (2.00)	2"	103.6 (4.08)	254.2 (10.01)	320.8 (12.63)	103.6 (4.08)
300-250	50.8 (2.00)	2"	103.6 (4.08)	260.6 (10.26)	330.9 (13.03)	103.6 (4.08)
300-300	63.5 (2.50)	2-1/2"	103.6 (4.08)	260.6 (10.26)	338.013.31 ()	103.6 (4.08)

Center & Rear Discharge Ports		
Section Size	Discharge Port for Center & Rear Section	Hole Diameter
100	3/4"	19.0 (.75)
150	3/4"	19.0 (.75)
200	1"	25.4 (1.00)
250	1-1/4"	30.2 (1.19)
300	1-1/4"	30.2 (1.19)

Dimensional Data

SAE 4-Bolt Connector Ports					
Size	G	H	J	K	L
3/4"	10.9 (.43)	22.2 (.875)	23.6 (.93)	47.6 (1.875)	3/8-16NC
1"	12.9 (.51)	26.1 (1.031)	26.1 (1.03)	52.3 (2.062)	3/8-16NC
1-1/4"	14.9 (.59)	30.1 (1.188)	29.2 (1.15)	58.7 (2.313)	7/16-14NC
1-1/2"	17.9 (.70)	35.7 (1.406)	34.7 (1.37)	69.8 (2.750)	1/2-13NC
2"	21.3 (.84)	42.8 (1.688)	38.8 (1.53)	77.7 (3.062)	1/2-13NC
2-1/2"	25.4 (1.00)	50.8 (2.000)	44.4 (1.75)	88.9 (3.500)	1/2-13NC

SAE 4-Bolt NPT Connectors are available. See Accessory Section

PD Factors

Drive Shaft	Factors
#1 - 1 1/4 Spline	187
#3 - 1 1/4 Keyed	187
#5 - 1 1/4 Keyed	187
Coupling	110

The maximum size and number of sections of a tandem pump for a given application is limited to the torque capability of the input drive shaft and the spline coupling between the sections. To determine this capability, a "PD Factor" is used:

P = PSI (The relief setting of each individual section).
 D = Displacement (In U.S. gallon per revolution of each section).

Example: Assume a double pump TP20450-450A-3D with front and rear sections on pressure at the same time at 2500 PSI and with the rear section on pressure at 1500 PSI but not at the same time as the front and center sections.

A. Drive Shaft:
 $PD = (2500) (.0394) + (2000) (.0394) = 216.7$
 Capability is **not** OK.

The "PD" factor for a no. 3 shaft is 187; therefore, to operate all three sections at once (to relieve valve pressure) would exceed the torque capability of the drive shaft.

B. Coupling between front and center sections:
 $PD = (2000) (.0394) = 137.9$ vs. 110.
 Capability is **not** OK.

The "PD" factor for the coupling is 110. If the center and rear sections are on pressure at the same time. The coupling between the front and center sections must transmit the torque for the center and rear sections.

Inch equivalents for millimeter dimensions are shown in (**).

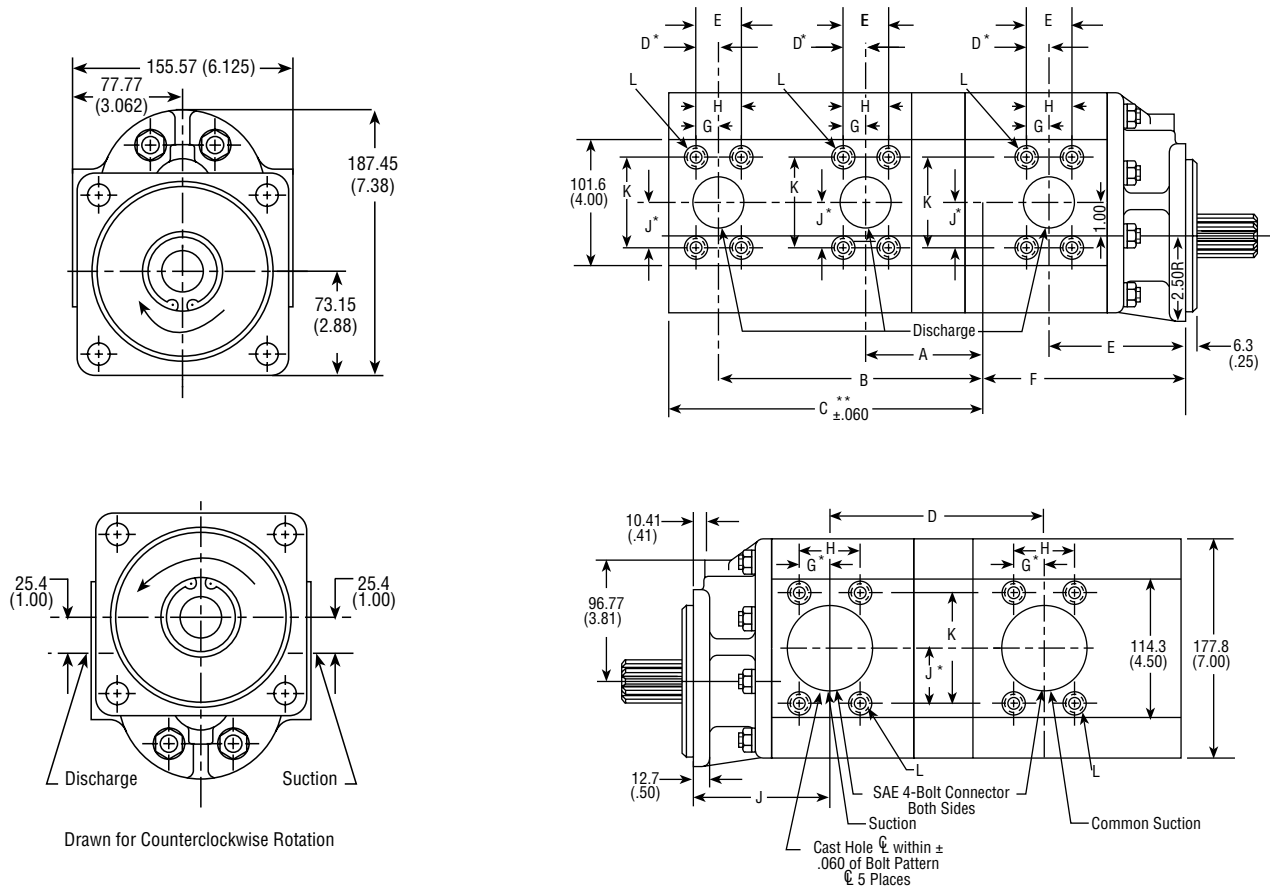

**Specifications
 for R20 Series**

Description Gear Pump
 Flow Range To 98 GPM (370.9 LTR)
 Displacements To 9.10 C.I.R.(149.12 CC's/REV.)
 Maximum Pressure to 2500 PSI (172 BAR)
 Maximum Speed to 2500 RPM
 Rotation Reversible
 Bearing Journal
 Construction Aluminum or Cast Iron*

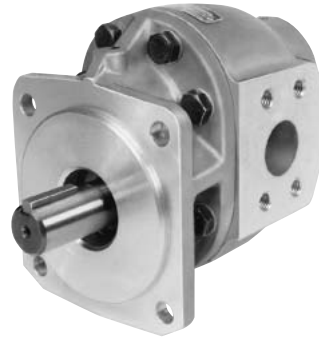

Performance Data

Pump Model	Section Size	Displacement/Revolution (Theoretical)					Maximum Pressure		Maximum Speed
		US Gallons	Cubic Inches	Liters	Cubic Centimeters	Imperial Gallons	PSI	BAR	RPM
R20	150	.0131	3.02	.0496	49.498	.0108	2500	172	2500
R20	200	.0175	4.04	.0662	66.204	.0146	2500	172	2500
R20	250	.0219	5.06	.0829	82.919	.0182	2500	172	2500
R20	300	.0262	6.05	.0992	99.142	.0218	2500 ⁽¹⁾	172	2500
R20	350	.0306	7.07	.1158	115.857	.0255	2500 ⁽²⁾	172	2500
R20	400	.0350	8.08	.1325	132.408	.0292	2500	172	2500
R20	450	.0394	9.10	.1491	149.123	.0328	2500	172	2500

Notes: (1) 2100 PSI maximum due to torque limitations of No. 4 shaft. (2) 1800 PSI maximum due to torque limitations of No. 4 shaft
 All data based on SAE 10W oil at 150°F. Available with Viton® Seals.

*Some models and sizes are available for pressure up to 3500 PSI. Cast-iron not available on all models. Consult factory for availability.



CAUTION: "Inlet vacuum" should not exceed 5" Hg at normal operating speed and temperature. Operation of pumps in excess of 5" Hg requires factory approval.

Dimensional Data

Mounting Dimensions								
PUMP SIZE	For B & C 4-Bolt & B & C 2-Bolt Flanges		SAE 4-Bolt Both Ports		SAE 4-Bolt Port Both Sides		Shipping Weights	
	A	B	Conn. Sz.	Hole Dia.	Conn. Sz.	Hole Dia.	lbs.	kgs.
R20150	104.6 (4.12)	167.8 (6.61)	—	—	1"	25.4 (1.00)	19	8.62
R20200	104.6 (4.12)	167.8 (6.61)	—	—	1"	25.4 (1.00)	20	9.07
R20250	104.6 (4.12)	167.8 (6.61)	1-1/4"	35.0 (1.38)	1-1/4"	31.7 (1.25)	21	9.53
R20300	104.6 (4.12)	175.2 (6.90)	1-1/2"	38.1 (1.50)	1-1/4"	31.7 (1.25)	22	9.98
R20350	110.4 (4.35)	182.3 (7.18)	1-1/2"	35.0 (1.38)	1-1/2"	38.1 (1.50)	23	10.4
R20400	110.4 (4.35)	189.7 (7.47)	—	—	1-1/2"	38.1 (1.50)	24	10.9
R20450	118.3 (4.66)	196.8 (7.75)	—	—	1-1/2"	38.1 (1.50)	25	11.3

SAE 4-Bolt Connector Ports					
Size	C	D	E	F	G
1"	12.9 (.51)	26.1 (1.031)	26.1 (1.03)	52.3 (2.062)	3/8-16NC
1-1/4"	14.9 (.59)	30.1 (1.188)	29.2 (1.15)	58.7 (2.313)	7/16-14NC
1-1/2"	17.7 (.70)	35.7 (1.406)	34.7 (1.37)	69.8 (2.750)	1/2-13NC

SAE 4-Bolt NPT Connectors are available. See Accessory Section

Inch equivalents for millimeter dimensions are shown in (**).

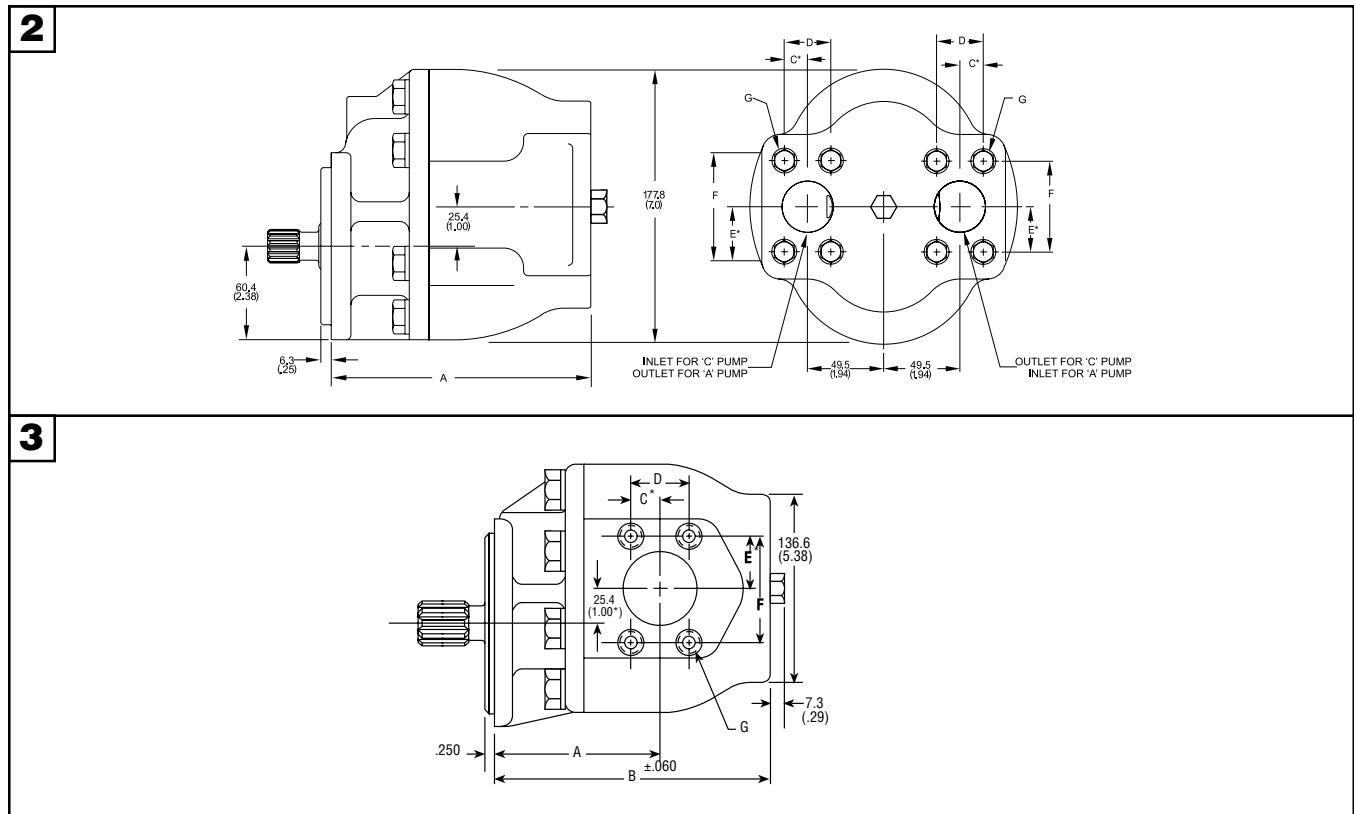

**Specifications
for PB20 Series**

Description Gear Pump
Flow Range To 98 GPM Per PB20 Section (370.9 LTR.)
Displacements To 9.10 C.I.R. Per Section (149.12 CC's/REV.)
Maximum Pressure to 2500 PSI (172 BAR)
Maximum Speed to 2500 RPM
Rotation A or C
Bearing Journal
Construction Aluminum or Cast Iron*

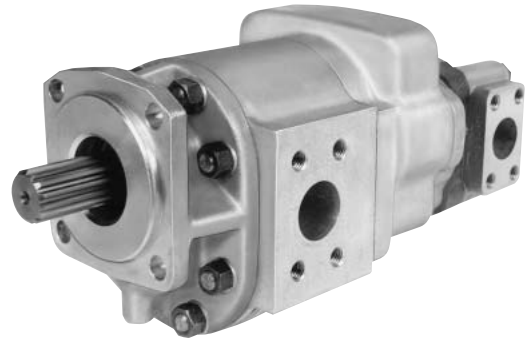

Performance Data

Pump Model	Section Size	Displacement/Revolution (Theoretical)					Maximum Pressure		Maximum Speed
		US Gallons	Cubic Inches	Liters	Cubic Centimeters	Imperial Gallons	PSI	BAR	RPM
PB20	100	.0087	2.01	.0330	32.938	.0072	2500	172	2500
PB20	150	.0131	3.02	.0496	49.498	.0108	2500	172	2500
PB20	200	.0175	4.04	.0662	66.204	.0146	2500	172	2500
PB20	250	.0219	5.06	.0829	82.919	.0182	2500	172	2500
PB20	300	.0262	6.05	.0992	99.142	.0218	2500	172	2500
PB20	350	.0306	7.07	.1158	115.857	.0255	2500	172	2500
PB20	400	.0350	8.08	.1325	132.408	.0292	2500	172	2500
PB20	450	.0394	9.10	.1491	149.123	.0328	2500	172	2500

All front section pumps are available with Viton® Seals.
*Cast-iron not available on all models. Consult factory for availability.

CAUTION: "Inlet vacuum" should not exceed 5" Hg at normal operating speed and temperature. Operation of pumps in excess of 5" Hg requires factory approval.

All data based on SAE 10W oil at 150° F.

Dimensional Data

PUMP MODEL	Port Sizes				MOUNTING DIMENSIONS		SHIP WT.	
	SUCTION		DISCHARGE		A	B	Lbs.	Kgs.
	Hole Dia 'P'	Con. Size	Hole Dia 'Q'	Con. Size				
PB20100	31.7 (1.25)	1/4"	19.0 (.75)	3/4"	91.4 (3.60)	202.1 (7.96)	22	8.21
PB20150	31.7 (1.25)	1/4"	19.0 (.75)	3/4"	91.4 (3.60)	210.3 (8.28)	22	8.21
PB20200	31.7 (1.25)	1/4"	25.4 (1.00)	1.00"	92.5 (3.75)	216.9 (8.54)	24	8.35
PB20250	38.1 (1.50)	1/2"	30.2 (1.19)	1/4"	101.6 (4.00)	224.0 (8.82)	25	9.33
PB20300	38.1 (1.50)	1/2"	30.2 (1.19)	1/4"	105.1 (4.14)	231.3 (9.11)	26	9.70
PB20350	38.1 (1.50)	1/2"	30.2 (1.19)	1/4"	110.4 (4.35)	238.2 (9.38)	30	11.19
PB20400	50.8 (2.00)	2.00"	34.7 (1.37)	1/2"	110.4 (4.35)	245.6 (9.67)	32	11.94
PB20450	50.8 (2.00)	2.00"	34.7 (1.37)	1/2"	118.3 (4.66)	252.7 (9.95)	36	13.43

CONNECTOR CHART					
Con. Size	F	G	H	J	K
3/4"	10.9 (.43)	22.2 (.875)	23.6 (.93)	47.6 (1.875)	3/8-16NC
1.00	12.9 (.51)	26.1 (1.031)	26.1 (1.03)	52.3 (2.062)	3/8-16NC
1 1/4"	14.9 (.59)	30.1 (1.188)	29.2 (1.15)	58.7 (2.313)	7/16-14NC
1 1/2"	17.7 (.70)	35.7 (1.406)	34.7 (1.37)	69.8 (2.750)	1/2-13NC
2.00	21.3 (.84)	42.8 (1.688)	38.8 (1.53)	77.7 (3.062)	1/2-13NC

SAE 4-Bolt NPT Connectors are available. See Accessory Section.

SECTION SIZES	Port Sizes								MOUNTING DIMENSIONS			SHIPPING WEIGHT	
	SUCTION				DISCHARGE				A	C	D	Lbs.	Kgs.
	Hole Dia.	Front Sect. Conn.	Hole Dia.	Ctr Sect. Conn.	Hole Dia.	Front Sect. Conn.	Hole Dia.	Ctr Sect. Conn.					
PB20150-100A & C	31.7 (1.25)	1/4"	31.7 (1.25)	1/4"	19.0 (.75)	3/4"	19.0 (.75)	3/4"	91.4 (3.60)	202.1 (7.96)	295.1 (11.62)	36	13.43
PB20150-150A & C	31.7 (1.25)	1/4"	31.7 (1.25)	1/4"	19.0 (.75)	3/4"	19.0 (.75)	3/4"	91.4 (3.60)	202.1 (7.96)	302.2 (11.90)	36	13.43
PB20200-150A & C	31.7 (1.25)	1/4"	31.7 (1.25)	1/4"	25.4 (1.00)	1.00"	19.0 (.75)	3/4"	95.2 (3.75)	225.0 (8.86)	326.6 (12.86)	37	13.80
PB20200-200A & C	31.7 (1.25)	1/4"	31.7 (1.25)	1/4"	25.4 (1.00)	1.00"	25.4 (1.00)	1.00"	95.2 (3.75)	241.3 (9.50)	362.9 (14.29)	42	15.67
PB20250-150A & C	38.1 (1.50)	1/2"	31.7 (1.25)	1/4"	30.2 (1.19)	1/4"	19.0 (.75)	3/4"	101.6 (4.00)	232.1 (9.14)	333.7 (13.14)	43	16.04
PB20250-200A & C	38.1 (1.50)	1/2"	31.7 (1.25)	1/4"	30.2 (1.19)	1/4"	25.4 (1.00)	1.00"	101.6 (4.00)	248.6 (9.79)	370.0 (14.57)	45	16.79
PB20250-250A & C	38.1 (1.50)	1/2"	38.1 (1.50)	1/2"	30.2 (1.19)	1/4"	30.2 (1.19)	1/4"	101.6 (4.00)	254.7 (10.03)	377.1 (14.85)	46	17.16
PB20300-150A & C	38.1 (1.50)	1/2"	31.7 (1.25)	1/4"	30.2 (1.19)	1/4"	19.0 (.75)	3/4"	105.1 (4.14)	239.5 (9.43)	341.1 (13.43)	42	15.67
PB20300-200A & C	38.1 (1.50)	1/2"	31.7 (1.25)	1/4"	30.2 (1.19)	1/4"	25.4 (1.00)	1.00"	105.1 (4.14)	255.7 (10.07)	377.4 (14.86)	43	16.04
PB20300-250A & C	38.1 (1.50)	1/2"	38.1 (1.50)	1/2"	30.2 (1.19)	1/4"	30.2 (1.19)	1/4"	105.1 (4.14)	262.1 (10.32)	384.5 (15.14)	45	16.79
PB20300-300A & C	38.1 (1.50)	1/2"	38.1 (1.50)	1/2"	30.2 (1.19)	1/4"	30.2 (1.19)	1/4"	105.1 (4.14)	265.6 (10.46)	391.9 (15.43)	52	19.40
PB20350-150A & C	38.1 (1.50)	1/2"	31.7 (1.25)	1/4"	30.2 (1.19)	1/4"	19.0 (.75)	3/4"	110.4 (4.35)	246.3 (9.70)	347.9 (13.70)	44	16.41
PB20350-200A & C	38.1 (1.50)	1/2"	31.7 (1.25)	1/4"	30.2 (1.19)	1/4"	25.4 (1.00)	1.00"	110.4 (4.35)	267.8 (10.35)	384.5 (15.14)	45	16.79
PB20350-250A & C	38.1 (1.50)	1/2"	38.1 (1.50)	1/2"	30.2 (1.19)	1/4"	30.2 (1.19)	1/4"	110.4 (4.35)	269.7 (10.60)	391.9 (15.43)	48	17.90
PB20350-300A & C	38.1 (1.50)	1/2"	38.1 (1.50)	1/2"	30.2 (1.19)	1/4"	30.2 (1.19)	1/4"	110.4 (4.35)	272.7 (10.74)	399.0 (15.71)	54	20.14
PB20400-150A & C	50.8 (2.00)	2.00"	31.7 (1.25)	1/4"	34.7 (1.37)	1/2"	19.0 (.75)	3/4"	110.4 (4.35)	253.4 (9.98)	354.8 (13.97)	43	16.04
PB20400-200A & C	50.8 (2.00)	2.00"	31.7 (1.25)	1/4"	34.7 (1.37)	1/2"	19.0 (.75)	1.00"	110.4 (4.35)	270.0 (10.63)	391.9 (15.43)	49	18.28
PB20400-250A & C	50.8 (2.00)	2.00"	38.1 (1.50)	1/2"	34.7 (1.37)	1/2"	30.2 (1.19)	1/4"	110.4 (4.35)	276.3 (10.88)	399.0 (15.71)	51	19.02
PB20400-300A & C	50.8 (2.00)	2.00"	38.1 (1.50)	1/2"	34.7 (1.37)	1/2"	30.2 (1.19)	1/4"	110.4 (4.35)	279.9 (11.02)	406.1 (15.99)	55	20.52
PB20450-150A & C	50.8 (2.00)	2.00"	31.7 (1.25)	1/4"	34.7 (1.37)	1/2"	19.0 (.75)	3/4"	118.3 (4.66)	260.8 (10.27)	362.2 (14.26)	48	17.90
PB20450-200A & C	50.8 (2.00)	2.00"	31.7 (1.25)	1/4"	34.7 (1.37)	1/2"	25.4 (1.00)	1.00"	118.3 (4.66)	277.3 (10.92)	399.0 (15.71)	50	18.68
PB20450-250A & C	50.8 (2.00)	2.00"	38.1 (1.50)	1/2"	34.7 (1.37)	1/2"	30.2 (1.19)	1/4"	118.3 (4.66)	283.7 (11.17)	406.1 (15.99)	52	19.40
PB20450-300A & C	50.8 (2.00)	2.00"	38.1 (1.50)	1/2"	34.7 (1.37)	1/2"	30.2 (1.19)	1/4"	118.3 (4.66)	287.2 (11.31)	413.5 (16.28)	56	20.89

Dimensional Data

Inch equivalents for millimeter dimensions are shown in (**).

PB20 Series Front Section — One Place with 2-Bolt Transition Plate

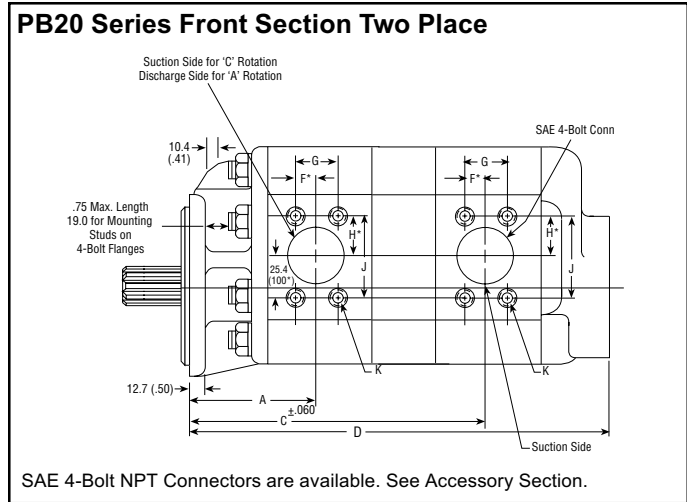
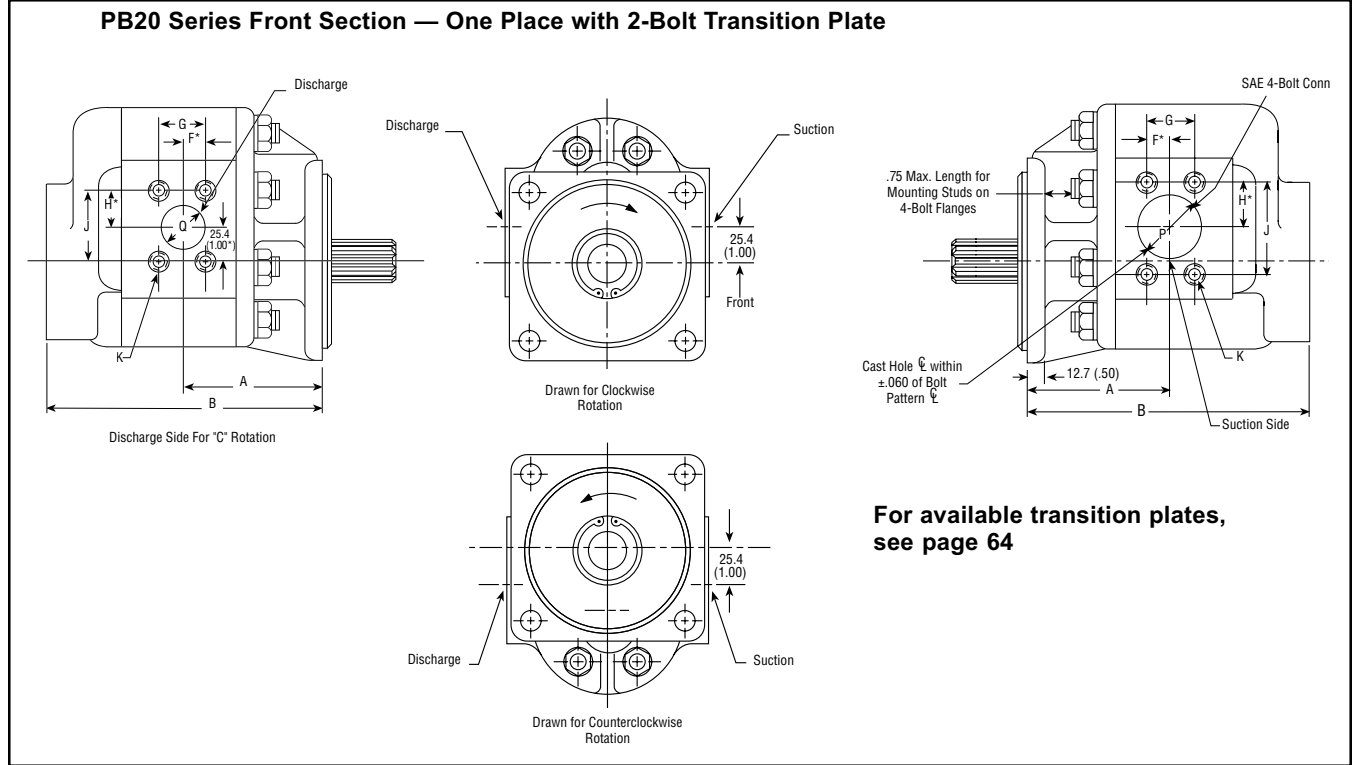

**Specifications
 for NST20 Series**

Description Flow-Sensitive Unloading Gear Pumps
 Combined Flow Range To 98 GPM Per Section (370.9 LTR.)
 Displacements... To 9.10 C.I.R Each Section (149.12 CC's/REV.)
 Maximum Pressure to 2500 PSI (172 BAR)
 Maximum Speed to 2500 RPM
 Rotation A or C
 Bearings Journal
 Construction Aluminum

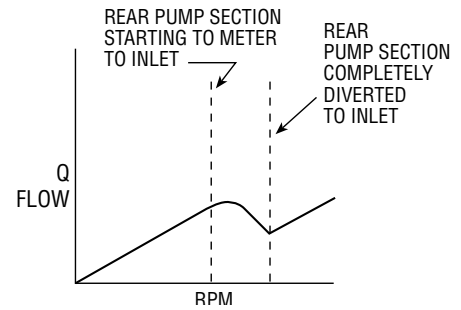
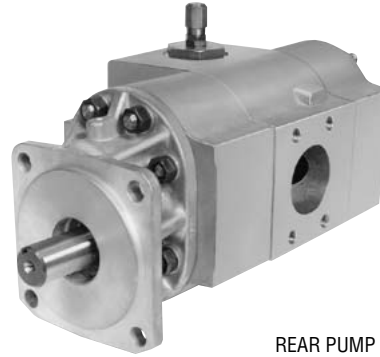

Tandem Pump with Flow Sensitive Unloading Valve

At low pump speeds the flow from both pump sections is to the circuit. As speed increases, the rear pump section begins to bypass internally to the inlet of the front pump section. After approximately a 400 RPM spread, the rear pump is completely bypassing and only the flow of the front pump is to the circuit. The bypass set point is field adjustable within approximately ±200 RPM.

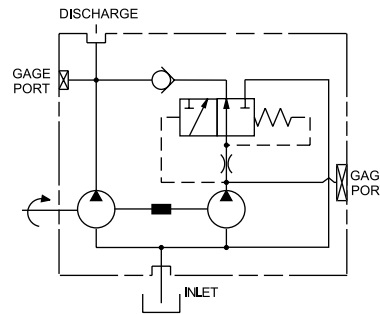

Performance Data Per Section

Pump Model	Section Size	Displacement/Revolution (Theoretical)					Maximum Pressure		Maximum Speed
		US Gallons	Cubic Inches	Liters	Cubic Centimeters	Imperial Gallons	PSI	BAR	
NST20	150	.0131	3.02	.0496	49.849	.0108	2500	172	2500
NST20	200	.0175	4.04	.0662	66.204	.0146	2500	172	2500
NST20	250	.0219	5.06	.0829	82.909	.0182	2500	172	2500
NST20	300	.0262	6.05	.0992	99.142	.0218	2500	172	2500
NST20	350	.0306	7.07	.1158	115.857	.0255	2500	172	2500
NST20	400	.0350	8.08	.1325	132.408	.0292	2500	172	2500
NST20	450	.0394	9.10	.1491	149.123	.0328	2500	172	2500

All data based on SAE 10W oil at 150 F. Available with Viton® Seals.

CAUTION: "Inlet vacuum" should not exceed 5" Hg at normal operating speed and temperature. Operation of pumps in excess of 5" Hg requires factory approval.

Dimensional Data

MOUNTING DIMENSIONS								
FRONT SECTION SIZE	REAR SECTION SIZE	CONN. SIZE	DISCHARGE FRONT SECTION HOLE DIA.	MOUNTING DIMENSIONS			SHIPPING WEIGHTS	
				A	B	C	lbs.	kgs.
20150	—150	1"	23.6 (.93)	91.4 (3.60)	179.5 (7.07)	322.0 (12.68)	56	20.9
	—200	1"	23.6 (.93)	91.4 (3.60)	179.5 (7.07)	343.9 (13.54)	57	21.3
	—250	1"	23.6 (.93)	91.4 (3.60)	179.5 (7.07)	353.8 (13.93)	58	21.7
	—300	1"	23.6 (.93)	91.4 (3.60)	179.5 (7.07)	361.1 (14.22)	60	22.4
	—350	1"	23.6 (.93)	91.4 (3.60)	179.5 (7.07)	351.2 (13.83)	62	23.1
	—400	1"	23.6 (.93)	91.4 (3.60)	179.5 (7.07)	358.3 (14.11)	64	23.9
	—450	1"	23.6 (.93)	91.4 (3.60)	179.5 (7.07)	365.7 (14.40)	66	24.6
20200	—150	1-1/2"	30.2 (1.19)	95.2 (3.75)	202.4 (7.97)	344.9 (13.58)	58	21.7
	—200	1-1/2"	30.2 (1.19)	95.2 (3.75)	202.4 (7.97)	366.7 (14.44)	59	22.0
	—250	1-1/2"	30.2 (1.19)	95.2 (3.75)	202.4 (7.97)	376.3 (14.83)	60	22.4
	—300	1-1/2"	30.2 (1.19)	95.2 (3.75)	202.4 (7.97)	383.7 (15.11)	62	23.1
	—350	1-1/2"	30.2 (1.19)	95.2 (3.75)	202.4 (7.97)	373.8 (14.72)	64	23.9
	—400	1-1/2"	30.2 (1.19)	95.2 (3.75)	202.4 (7.97)	381.0 (15.00)	66	24.6
	—450	1-1/2"	30.2 (1.19)	95.2 (3.75)	202.4 (7.97)	388.3 (15.29)	68	25.4
20250	—150	1-1/2"	30.2 (1.19)	101.6 (4.00)	209.5 (8.25)	352.0 (13.86)	59	21.7
	—200	1-1/2"	30.2 (1.19)	101.6 (4.00)	209.5 (8.25)	373.6 (14.71)	60	22.4
	—250	1-1/2"	30.2 (1.19)	101.6 (4.00)	209.5 (8.25)	383.7 (15.11)	62	23.1
	—300	1-1/2"	30.2 (1.19)	101.6 (4.00)	209.5 (8.25)	390.9 (15.39)	64	23.9
	—350	1-1/2"	30.2 (1.19)	101.6 (4.00)	209.5 (8.25)	381.0 (15.00)	66	24.6
	—400	1-1/2"	30.2 (1.19)	101.6 (4.00)	209.5 (8.25)	388.1 (15.28)	68	25.4
	—450	1-1/2"	30.2 (1.19)	101.6 (4.00)	209.5 (8.25)	395.4 (15.57)	70	26.1
20300	—150	1-1/2"	30.2 (1.19)	105.1 (4.14)	216.9 (8.54)	359.4 (14.15)	60	22.4
	—200	1-1/2"	30.2 (1.19)	105.1 (4.14)	216.9 (8.54)	381.0 (15.00)	64	23.9
	—250	1-1/2"	30.2 (1.19)	105.1 (4.14)	216.9 (8.54)	391.1 (15.40)	66	24.6
	—300	1-1/2"	30.2 (1.19)	105.1 (4.14)	216.9 (8.54)	398.2 (15.68)	68	25.4
	—350	1-1/2"	30.2 (1.19)	105.1 (4.14)	216.9 (8.54)	388.3 (15.29)	70	26.1
	—400	1-1/2"	30.2 (1.19)	105.1 (4.14)	216.9 (8.54)	395.4 (15.57)	72	26.9
	—450	1-1/2"	30.2 (1.19)	105.1 (4.14)	216.9 (8.54)	402.8 (15.86)	74	27.6
20350	—150	1-1/2"	30.2 (1.19)	110.4 (4.35)	224.0 (8.82)	366.5 (14.43)	62	23.1
	—200	1-1/2"	30.2 (1.19)	110.4 (4.35)	224.0 (8.82)	388.1 (15.28)	64	23.9
	—250	1-1/2"	30.2 (1.19)	110.4 (4.35)	224.0 (8.82)	398.2 (15.68)	66	24.6
	—300	1-1/2"	30.2 (1.19)	110.4 (4.35)	224.0 (8.82)	405.3 (15.96)	70	26.1
	—350	1-1/2"	30.2 (1.19)	110.4 (4.35)	224.0 (8.82)	395.4 (15.57)	72	26.9
	—400	1-1/2"	30.2 (1.19)	110.4 (4.35)	224.0 (8.82)	402.5 (15.85)	74	27.6
	—450	1-1/2"	30.2 (1.19)	110.4 (4.35)	224.0 (8.82)	409.9 (16.14)	76	28.4
20400	—150	1-1/2"	34.7 (1.37)	110.4 (4.35)	231.1 (9.10)	373.6 (14.71)	64	23.9
	—200	1-1/2"	34.7 (1.37)	110.4 (4.35)	231.1 (9.10)	395.2 (15.56)	66	24.6
	—250	1-1/2"	34.7 (1.37)	110.4 (4.35)	231.1 (9.10)	405.3 (15.96)	68	25.4
	—300	1-1/2"	34.7 (1.37)	110.4 (4.35)	231.1 (9.10)	412.4 (16.24)	70	26.1
	—350	1-1/2"	34.7 (1.37)	110.4 (4.35)	231.1 (9.10)	402.5 (15.85)	72	26.9
	—400	1-1/2"	34.7 (1.37)	110.4 (4.35)	231.1 (9.10)	409.7 (16.13)	76	28.4
	—450	1-1/2"	34.7 (1.37)	110.4 (4.35)	231.1 (9.10)	417.0 (16.42)	78	29.1
20450	—150	1-1/2"	34.7 (1.37)	118.3 (4.66)	238.5 (9.39)	381.0 (15.00)	66	24.6
	—200	1-1/2"	34.7 (1.37)	118.3 (4.66)	238.5 (9.39)	402.5 (15.85)	68	25.4
	—250	1-1/2"	34.7 (1.37)	118.3 (4.66)	238.5 (9.39)	412.7 (16.25)	70	26.1
	—300	1-1/2"	34.7 (1.37)	118.3 (4.66)	238.5 (9.39)	419.8 (16.53)	74	27.6
	—350	1-1/2"	34.7 (1.37)	118.3 (4.66)	238.5 (9.39)	409.9 (16.14)	76	28.4
	—400	1-1/2"	34.7 (1.37)	118.3 (4.66)	238.5 (9.39)	417.0 (16.42)	78	29.1
	—450	1-1/2"	34.7 (1.37)	118.3 (4.66)	238.5 (9.39)	424.4 (16.71)	80	29.9

SAE 4-BOLT CONNECTOR PORTS					
Size	F	G	H	J	K
1"	12.9 (.51)	26.1 (1.03)	26.1 (1.03)	52.3 (2.06)	3/8-16NC
1-1/2"	17.7 (.70)	35.5 (1.40)	34.7 (1.37)	69.8 (2.75)	1/2-13NC
2-1/2"	25.4 (1.00)	50.8 (2.00)	44.4 (1.75)	88.9 (3.50)	1/2-13NC



Dimensional Data

Inch equivalents for millimeter dimensions are shown in (**).

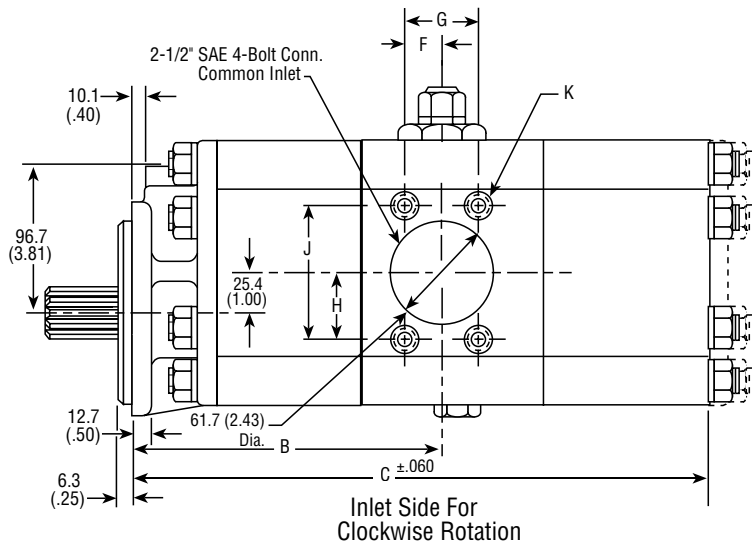
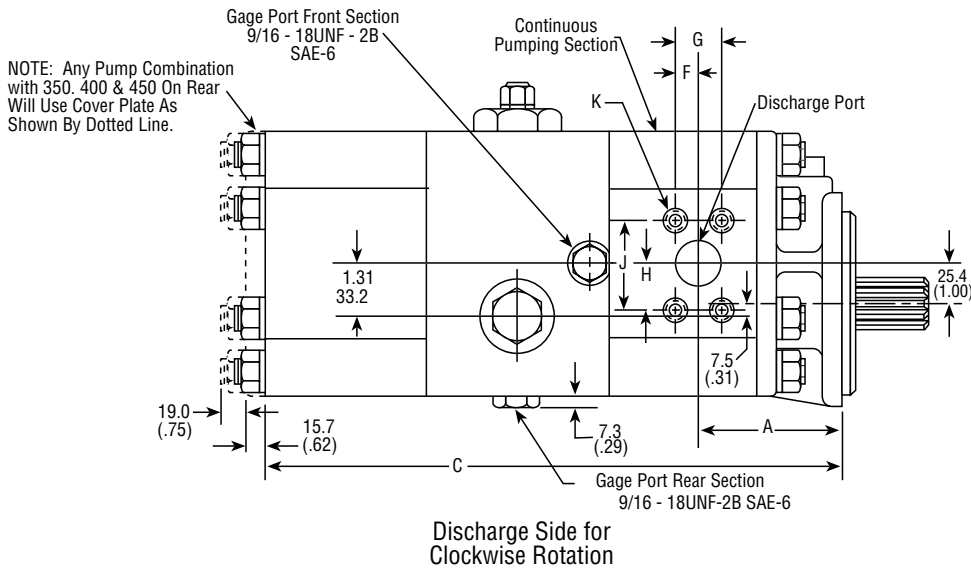
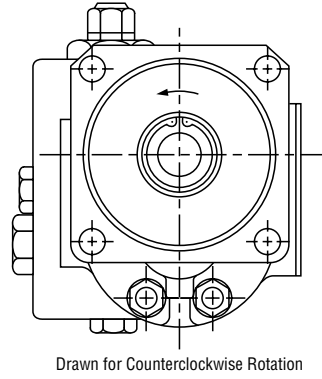
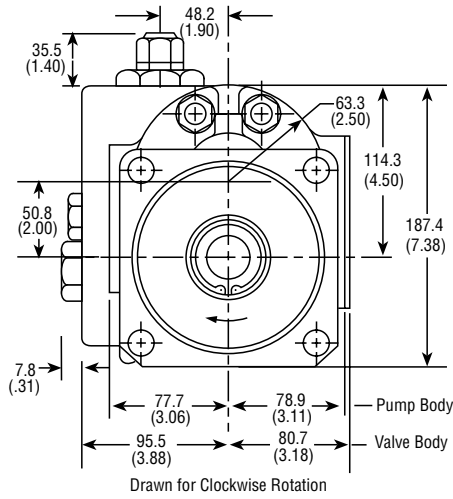

**Specifications
 for NSD20 Series**

Description Flow-Sensitive Unloading Gear Pumps
 Combined Flow Range To 98 GPM Per Section (370.9 LTR)
 Displacements... To 9.10 C.I.R. Each Section (149.12 CC's/REV.)
 Maximum Pressure to 2500 PSI (172 BAR)
 Maximum Speed to 2500 RPM
 Rotation A or C
 Bearings Journal
 Construction Aluminum

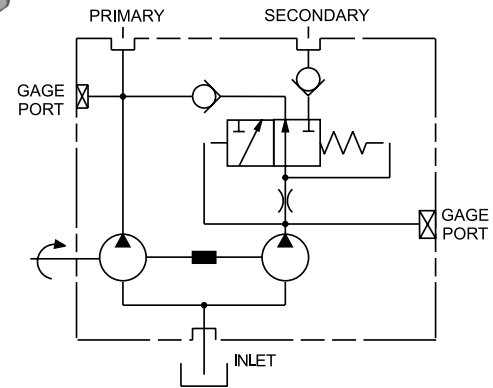
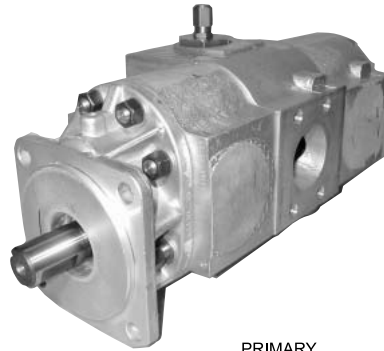

**Tandem Pump with Flow-Sensitive-Unloading Valve
 and Power Beyond Port For the Unloaded Pump**

This system consists of a tandem pump and unloading valve with the unloading valve being sensitive to pump speed. The system has primary and secondary discharge ports such that both pumping sections are diverted to the primary port at low pump speeds. At an intermediate pump speed the rear pump section is metered from the primary port and a portion is diverted to the secondary port. At a predetermined higher speed, the rear pumping section is completely diverted to the secondary port while all of the front pumping section flow is maintained at the primary port.

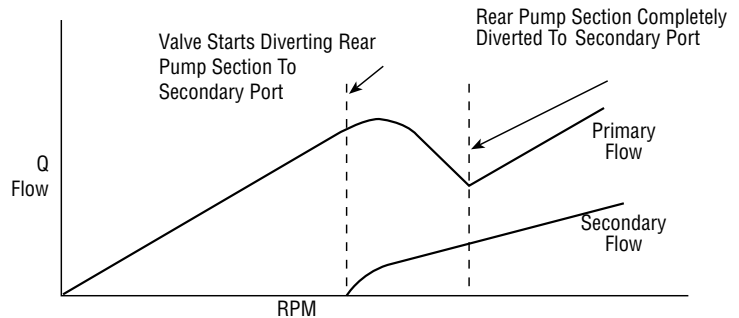

Performance Data Per Section

Pump Model	Section Size	Displacement/Revolution (Theoretical)					Maximum Pressure		Maximum Speed RPM
		US Gallons	Cubic Inches	Liters	Cubic Centimeters	Imperial Gallons	PSI	BAR	
NSD20	150	.0131	3.02	.0496	49.849	.0108	2500	172	2500
NSD20	200	.0175	4.04	.0662	66.204	.0146	2500	172	2500
NSD20	250	.0219	5.06	.0829	82.919	.0182	2500	172	2500
NSD20	300	.0262	6.05	.0992	99.142	.0218	2500	172	2500
NSD20	350	.0306	7.07	.1158	115.857	.0255	2500	172	2500
NSD20	400	.0350	8.08	.1325	132.408	.0292	2500	172	2500
NSD20	450	.0394	9.10	.1491	149.123	.0328	2500	172	2500

All data based on SAE 10W oil at 150°F. Available with Viton® Seals.



CAUTION: "Inlet vacuum" should not exceed 5" Hg at normal operating speed and temperature. Operation of pumps in excess of 5" Hg requires factory approval.

MOUNTING DIMENSIONS								
FRONT SECTION SIZE	REAR SECTION SIZE	CONN. SIZE	DISCHARGE FRONT SECTION HOLE DIA.	DISCHARGE FRONT SECTION			SHIPPING WEIGHTS	
				A	B	C	lbs.	kgs.
20150	—150	1"	23.6 (.93)	91.4 (3.60)	179.5 (7.07)	322.0 (12.68)	56	20.9
	—200	1"	23.6 (.93)	91.4 (3.60)	179.5 (7.07)	343.9 (13.54)	57	21.3
	—250	1"	23.6 (.93)	91.4 (3.60)	179.5 (7.07)	353.8 (13.93)	58	21.7
	—300	1"	23.6 (.93)	91.4 (3.60)	179.5 (7.07)	361.1 (14.22)	60	22.4
	—350	1"	23.6 (.93)	91.4 (3.60)	179.5 (7.07)	351.2 (13.83)	62	23.1
	—400	1"	23.6 (.93)	91.4 (3.60)	179.5 (7.07)	358.3 (14.11)	64	23.9
	—450	1"	23.6 (.93)	91.4 (3.60)	179.5 (7.07)	365.7 (14.40)	66	24.6
20200	—150	1-1/2"	30.2 (1.19)	95.2 (3.75)	202.4 (7.97)	344.9 (13.58)	58	21.7
	—200	1-1/2"	30.2 (1.19)	95.2 (3.75)	202.4 (7.97)	366.7 (14.44)	59	22.0
	—250	1-1/2"	30.2 (1.19)	95.2 (3.75)	202.4 (7.97)	376.3 (14.83)	60	22.4
	—300	1-1/2"	30.2 (1.19)	95.2 (3.75)	202.4 (7.97)	383.7 (15.11)	62	23.1
	—350	1-1/2"	30.2 (1.19)	95.2 (3.75)	202.4 (7.97)	373.8 (14.72)	64	23.9
	—400	1-1/2"	30.2 (1.19)	95.2 (3.75)	202.4 (7.97)	381.0 (15.00)	66	24.6
	—450	1-1/2"	30.2 (1.19)	95.2 (3.75)	202.4 (7.97)	388.3 (15.29)	68	25.4
20250	—150	1-1/2"	30.2 (1.19)	101.6 (4.00)	209.5 (8.25)	352.0 (13.86)	59	21.7
	—200	1-1/2"	30.2 (1.19)	101.6 (4.00)	209.5 (8.25)	373.6 (14.71)	60	22.4
	—250	1-1/2"	30.2 (1.19)	101.6 (4.00)	209.5 (8.25)	383.7 (15.11)	62	23.1
	—300	1-1/2"	30.2 (1.19)	101.6 (4.00)	209.5 (8.25)	390.9 (15.39)	64	23.9
	—350	1-1/2"	30.2 (1.19)	101.6 (4.00)	209.5 (8.25)	381.0 (15.00)	66	24.6
	—400	1-1/2"	30.2 (1.19)	101.6 (4.00)	209.5 (8.25)	388.1 (15.28)	68	25.4
	—450	1-1/2"	30.2 (1.19)	101.6 (4.00)	209.5 (8.25)	395.4 (15.57)	70	26.1
20300	—150	1-1/2"	30.2 (1.19)	105.1 (4.14)	216.9 (8.54)	359.4 (14.15)	60	22.4
	—200	1-1/2"	30.2 (1.19)	105.1 (4.14)	216.9 (8.54)	381.0 (15.00)	64	23.9
	—250	1-1/2"	30.2 (1.19)	105.1 (4.14)	216.9 (8.54)	391.1 (15.40)	66	24.6
	—300	1-1/2"	30.2 (1.19)	105.1 (4.14)	216.9 (8.54)	398.2 (15.68)	68	25.4
	—350	1-1/2"	30.2 (1.19)	105.1 (4.14)	216.9 (8.54)	388.3 (15.29)	70	26.1
	—400	1-1/2"	30.2 (1.19)	105.1 (4.14)	216.9 (8.54)	395.4 (15.57)	72	26.9
	—450	1-1/2"	30.2 (1.19)	105.1 (4.14)	216.9 (8.54)	402.8 (15.86)	74	27.6
20350	—150	1-1/2"	30.2 (1.19)	110.4 (4.35)	224.0 (8.82)	366.5 (14.43)	62	23.1
	—200	1-1/2"	30.2 (1.19)	110.4 (4.35)	224.0 (8.82)	388.1 (15.28)	64	23.9
	—250	1-1/2"	30.2 (1.19)	110.4 (4.35)	224.0 (8.82)	398.2 (15.68)	66	24.6
	—300	1-1/2"	30.2 (1.19)	110.4 (4.35)	224.0 (8.82)	405.3 (15.96)	70	26.1
	—350	1-1/2"	30.2 (1.19)	110.4 (4.35)	224.0 (8.82)	395.4 (15.57)	72	26.9
	—400	1-1/2"	30.2 (1.19)	110.4 (4.35)	224.0 (8.82)	402.5 (15.85)	74	27.6
	—450	1-1/2"	30.2 (1.19)	110.4 (4.35)	224.0 (8.82)	409.9 (16.14)	76	28.4
20400	—150	1-1/2"	34.7 (1.37)	110.4 (4.35)	231.1 (9.10)	373.6 (14.71)	64	23.9
	—200	1-1/2"	34.7 (1.37)	110.4 (4.35)	231.1 (9.10)	395.2 (15.56)	66	24.6
	—250	1-1/2"	34.7 (1.37)	110.4 (4.35)	231.1 (9.10)	405.3 (15.96)	68	25.4
	—300	1-1/2"	34.7 (1.37)	110.4 (4.35)	231.1 (9.10)	412.4 (16.24)	70	26.1
	—350	1-1/2"	34.7 (1.37)	110.4 (4.35)	231.1 (9.10)	402.5 (15.85)	72	26.9
	—400	1-1/2"	34.7 (1.37)	110.4 (4.35)	231.1 (9.10)	409.7 (16.13)	76	28.4
	—450	1-1/2"	34.7 (1.37)	110.4 (4.35)	231.1 (9.10)	417.0 (16.42)	78	29.1
20450	—150	1-1/2"	34.7 (1.37)	118.3 (4.66)	238.5 (9.39)	381.0 (15.00)	66	24.6
	—200	1-1/2"	34.7 (1.37)	118.3 (4.66)	238.5 (9.39)	402.5 (15.85)	68	25.4
	—250	1-1/2"	34.7 (1.37)	118.3 (4.66)	238.5 (9.39)	412.7 (16.25)	70	26.1
	—300	1-1/2"	34.7 (1.37)	118.3 (4.66)	238.5 (9.39)	419.8 (16.53)	74	27.6
	—350	1-1/2"	34.7 (1.37)	118.3 (4.66)	238.5 (9.39)	409.9 (16.14)	76	28.4
	—400	1-1/2"	34.7 (1.37)	118.3 (4.66)	238.5 (9.39)	417.0 (16.42)	78	29.1
	—450	1-1/2"	34.7 (1.37)	118.3 (4.66)	238.5 (9.39)	424.4 (16.71)	80	29.9

SAE 4-BOLT CONNECTOR PORTS					
Size	F	G	H	J	K
1"	12.9 (.51)	26.1 (1.03)	26.1 (1.03)	52.3 (2.06)	3/8-16NC
1-1/4"	14.7 (.58)	29.4 (1.16)	29.3 (1.15)	58.6 (2.31)	7/16-14NC
1-1/2"	17.7 (.70)	35.5 (1.40)	34.7 (1.37)	69.8 (2.75)	1/2-13NC
2-1/2"	25.4 (1.00)	50.8 (2.00)	44.4 (1.75)	88.9 (3.50)	1/2-13NC

Dimensional Data

Inch equivalents for millimeter dimensions are shown in (**).

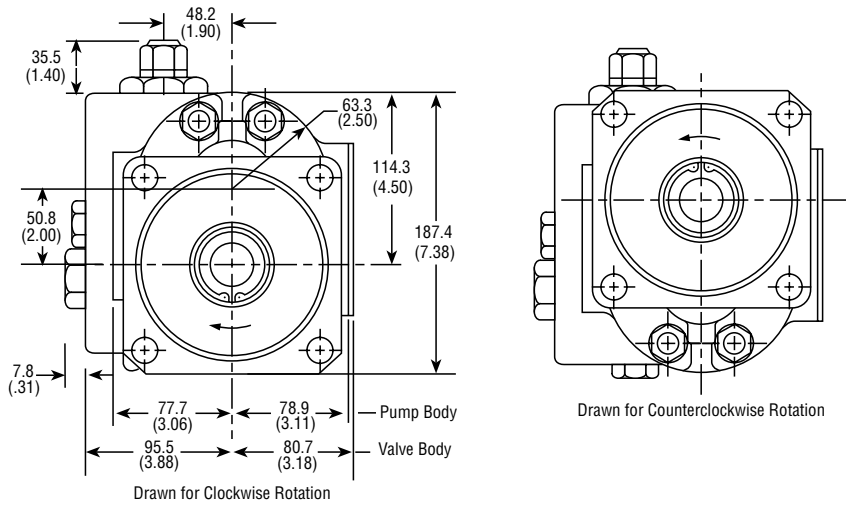

Drawn for Counterclockwise Rotation

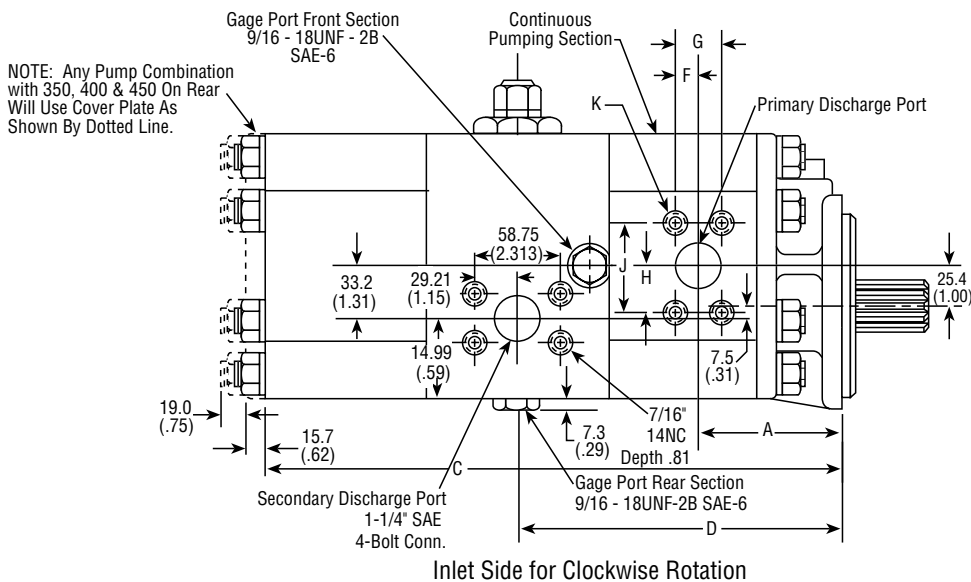
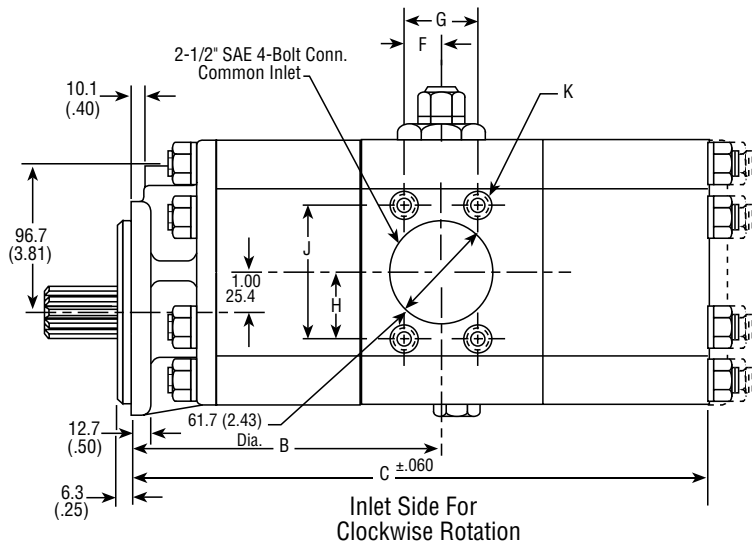

NOTE: Any Pump Combination with 350, 400 & 450 On Rear Will Use Cover Plate As Shown By Dotted Line.

**Specifications
 for NSH20 Series**

Description Pressure-Sensitive Unloading Gear Pumps
 Combined Flow Range To 98 GPM Per Section (370.9 LTR)
 Displacements ... To 9.10 C.I.R. Each Section (149.12 CC's/REV.)
 Maximum Pressure to 2500 PSI (172 BAR)
 Maximum Speed to 2500 RPM
 Rotation A or C
 Bearings Journal
 Construction Aluminum



Tandem Pump with Pressure-Sensitive Unloading Valve

The NSH pump system uses an unloading valve to divert the flow from one section of a tandem pump. The system is designed to limit the hydraulic horsepower, and thus limit the horsepower taken from the prime mover. Flow is supplied from both pumping sections at low, working pressure and from only the front pumping section at high pressure. As the system pressure increases to a predetermined value, a pilot relief valve opens, causing the main spool to divert the rear pumping section to the common inlet port, while the front pumping section continues to supply fluid to the system.

When the system pressure decreases to the predetermined value for which it was set, the relief valve closes, causing the main spool to divert the unloaded flow of the rear pumping section back into the system. The rear section can be manually unloaded at any time, regardless of system pressure, by venting the manual unload pilot port.

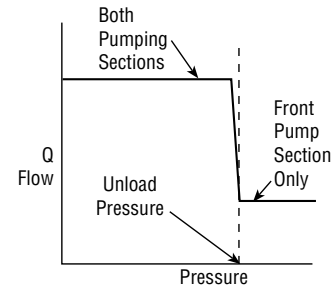
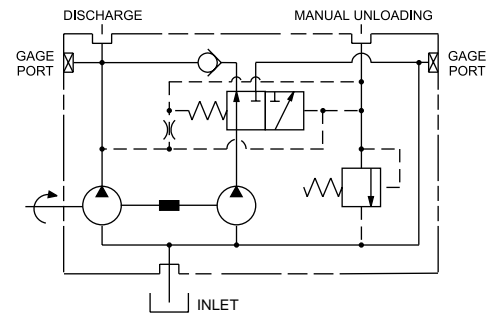

Performance Data Per Section

Pump Model	Section Size	Displacement/Revolution (Theoretical)					Maximum Pressure		Maximum Speed RPM
		US Gallons	Cubic Inches	Liters	Cubic Centimeters	Imperial Gallons	PSI	BAR	
NSH20	150	.0131	3.02	.0496	49.849	.0108	2500	172	2500
NSH20	200	.0175	4.04	.0662	66.204	.0146	2500	172	2500
NSH20	250	.0219	5.06	.0829	82.919	.0182	2500	172	2500
NSH20	300	.0262	6.05	.0992	99.142	.0218	2500	172	2500
NSH20	350	.0306	7.07	.1158	115.857	.0255	2500	172	2500
NSH20	400	.0350	8.08	.1325	132.408	.0292	2500	172	2500
NSH20	450	.0394	9.10	.1491	149.123	.0328	2500	172	2500

All data based on SAE 10W oil at 150°F. Available with Viton® Seals.



CAUTION: "Inlet vacuum" should not exceed 5" Hg at normal operating speed and temperature. Operation of pumps in excess of 5" Hg requires factory approval.

Dimensional Data

MOUNTING DIMENSIONS								
FRONT SECTION SIZE	REAR SECTION SIZE	CONN. SIZE	DISCHARGE FRONT SECTION HOLE DIA.	MOUNTING DIMENSIONS			SHIPPING WEIGHTS	
				A	B	C	lbs.	kgs.
20150	—150	1"	23.6 (.93)	91.4 (3.60)	179.5 (7.07)	322.0 (12.68)	56	20.9
	—200	1"	23.6 (.93)	91.4 (3.60)	179.5 (7.07)	343.9 (13.54)	57	21.3
	—250	1"	23.6 (.93)	91.4 (3.60)	179.5 (7.07)	353.8 (13.93)	58	21.7
	—300	1"	23.6 (.93)	91.4 (3.60)	179.5 (7.07)	361.1 (14.22)	60	22.4
	—350	1"	23.6 (.93)	91.4 (3.60)	179.5 (7.07)	351.2 (13.83)	62	23.1
	—400	1"	23.6 (.93)	91.4 (3.60)	179.5 (7.07)	358.3 (14.11)	64	23.9
	—450	1"	23.6 (.93)	91.4 (3.60)	179.5 (7.07)	365.7 (14.40)	66	24.6
20200	—150	1-1/2"	30.2 (1.19)	95.2 (3.75)	202.4 (7.97)	344.9 (13.58)	58	21.7
	—200	1-1/2"	30.2 (1.19)	95.2 (3.75)	202.4 (7.97)	366.7 (14.44)	59	22.0
	—250	1-1/2"	30.2 (1.19)	95.2 (3.75)	202.4 (7.97)	376.3 (14.83)	60	22.4
	—300	1-1/2"	30.2 (1.19)	95.2 (3.75)	202.4 (7.97)	383.7 (15.11)	62	23.1
	—350	1-1/2"	30.2 (1.19)	95.2 (3.75)	202.4 (7.97)	373.8 (14.72)	64	23.9
	—400	1-1/2"	30.2 (1.19)	95.2 (3.75)	202.4 (7.97)	381.0 (15.00)	66	24.6
	—450	1-1/2"	30.2 (1.19)	95.2 (3.75)	202.4 (7.97)	388.3 (15.29)	68	25.4
20250	—150	1-1/2"	30.2 (1.19)	101.6 (4.00)	209.5 (8.25)	352.0 (13.86)	59	21.7
	—200	1-1/2"	30.2 (1.19)	101.6 (4.00)	209.5 (8.25)	373.6 (14.71)	60	22.4
	—250	1-1/2"	30.2 (1.19)	101.6 (4.00)	209.5 (8.25)	383.7 (15.11)	62	23.1
	—300	1-1/2"	30.2 (1.19)	101.6 (4.00)	209.5 (8.25)	390.9 (15.39)	64	23.9
	—350	1-1/2"	30.2 (1.19)	101.6 (4.00)	209.5 (8.25)	381.0 (15.00)	66	24.6
	—400	1-1/2"	30.2 (1.19)	101.6 (4.00)	209.5 (8.25)	388.1 (15.28)	68	25.4
	—450	1-1/2"	30.2 (1.19)	101.6 (4.00)	209.5 (8.25)	395.4 (15.57)	70	26.1
20300	—150	1-1/2"	30.2 (1.19)	105.1 (4.14)	216.9 (8.54)	359.4 (14.15)	60	22.4
	—200	1-1/2"	30.2 (1.19)	105.1 (4.14)	216.9 (8.54)	381.0 (15.00)	64	23.9
	—250	1-1/2"	30.2 (1.19)	105.1 (4.14)	216.9 (8.54)	391.1 (15.40)	66	24.6
	—300	1-1/2"	30.2 (1.19)	105.1 (4.14)	216.9 (8.54)	398.2 (15.68)	68	25.4
	—350	1-1/2"	30.2 (1.19)	105.1 (4.14)	216.9 (8.54)	388.3 (15.29)	70	26.1
	—400	1-1/2"	30.2 (1.19)	105.1 (4.14)	216.9 (8.54)	395.4 (15.57)	72	26.9
	—450	1-1/2"	30.2 (1.19)	105.1 (4.14)	216.9 (8.54)	402.8 (15.86)	74	27.6
20350	—150	1-1/2"	30.2 (1.19)	110.4 (4.35)	224.0 (8.82)	366.5 (14.43)	62	23.1
	—200	1-1/2"	30.2 (1.19)	110.4 (4.35)	224.0 (8.82)	388.1 (15.28)	64	23.9
	—250	1-1/2"	30.2 (1.19)	110.4 (4.35)	224.0 (8.82)	398.2 (15.68)	66	24.6
	—300	1-1/2"	30.2 (1.19)	110.4 (4.35)	224.0 (8.82)	405.3 (15.96)	70	26.1
	—350	1-1/2"	30.2 (1.19)	110.4 (4.35)	224.0 (8.82)	395.4 (15.57)	72	26.9
	—400	1-1/2"	30.2 (1.19)	110.4 (4.35)	224.0 (8.82)	402.5 (15.85)	74	27.6
	—450	1-1/2"	30.2 (1.19)	110.4 (4.35)	224.0 (8.82)	409.9 (16.14)	76	28.4
20400	—150	1-1/2"	34.7 (1.37)	110.4 (4.35)	231.1 (9.10)	373.6 (14.71)	64	23.9
	—200	1-1/2"	34.7 (1.37)	110.4 (4.35)	231.1 (9.10)	395.2 (15.56)	66	24.6
	—250	1-1/2"	34.7 (1.37)	110.4 (4.35)	231.1 (9.10)	405.3 (15.96)	68	25.4
	—300	1-1/2"	34.7 (1.37)	110.4 (4.35)	231.1 (9.10)	412.4 (16.24)	70	26.1
	—350	1-1/2"	34.7 (1.37)	110.4 (4.35)	231.1 (9.10)	402.5 (15.85)	72	26.9
	—400	1-1/2"	34.7 (1.37)	110.4 (4.35)	231.1 (9.10)	409.7 (16.13)	76	28.4
	—450	1-1/2"	34.7 (1.37)	110.4 (4.35)	231.1 (9.10)	417.016.42 ()	78	29.1
20450	—150	1-1/2"	34.7 (1.37)	118.3 (4.66)	238.5 (9.39)	381.0 (15.00)	66	24.6
	—200	1-1/2"	34.7 (1.37)	118.3 (4.66)	238.5 (9.39)	402.5 (15.85)	68	25.4
	—250	1-1/2"	34.7 (1.37)	118.3 (4.66)	238.5 (9.39)	412.7 (16.25)	70	26.1
	—300	1-1/2"	34.7 (1.37)	118.3 (4.66)	238.5 (9.39)	419.8 (16.53)	74	27.6
	—350	1-1/2"	34.7 (1.37)	118.3 (4.66)	238.5 (9.39)	409.9 (16.14)	76	28.4
	—400	1-1/2"	34.7 (1.37)	118.3 (4.66)	238.5 (9.39)	417.0 (16.42)	78	29.1
	—450	1-1/2"	34.7 (1.37)	118.3 (4.66)	238.5 (9.39)	424.4 (16.71)	80	29.9

SAE 4-BOLT CONNECTOR PORTS					
Size	F	G	H	J	K
1"	12.9 (.51)	26.1 (1.03)	26.1 (1.03)	52.3 (2.06)	3/8-16NC
1-1/2"	17.7 (.70)	35.5 (1.40)	34.7 (1.37)	69.8 (2.75)	1/2-13NC
2-1/2"	25.4 (1.00)	50.8 (2.00)	44.4 (1.75)	88.9 (3.50)	1/2-13NC



Dimensional Data

Inch equivalents for millimeter dimensions are shown in (**).

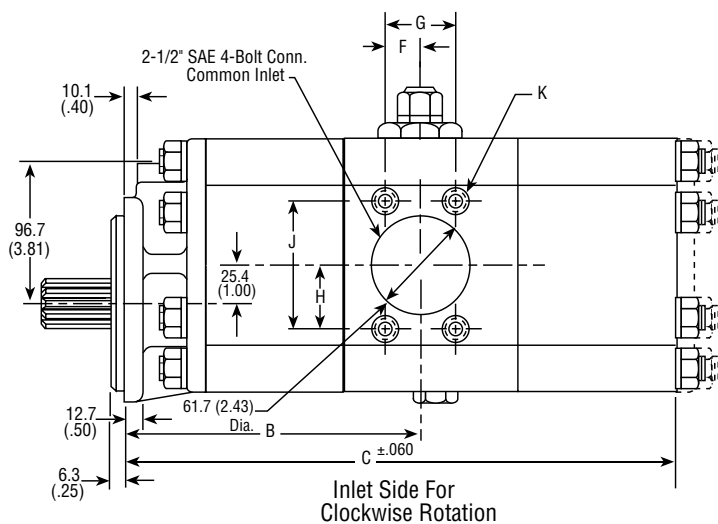
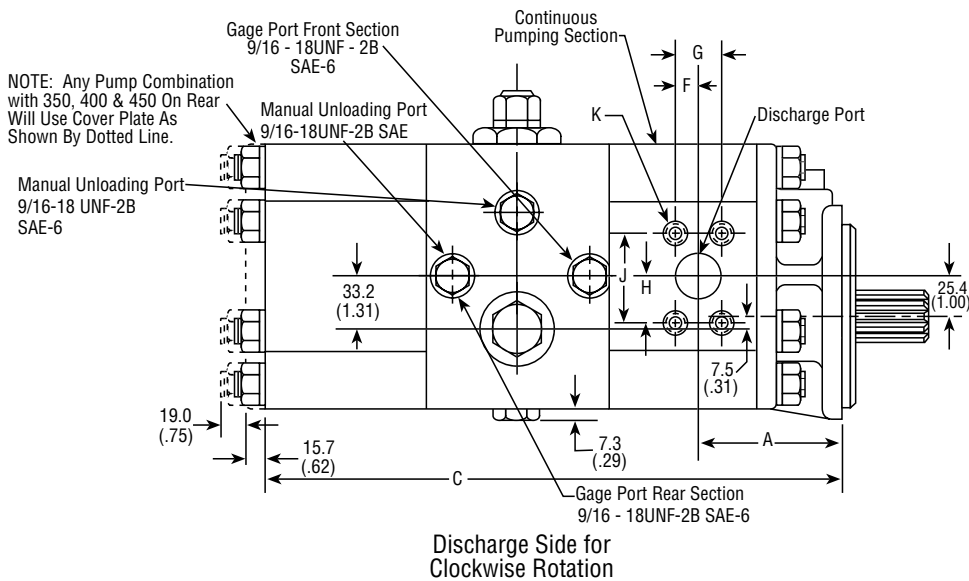
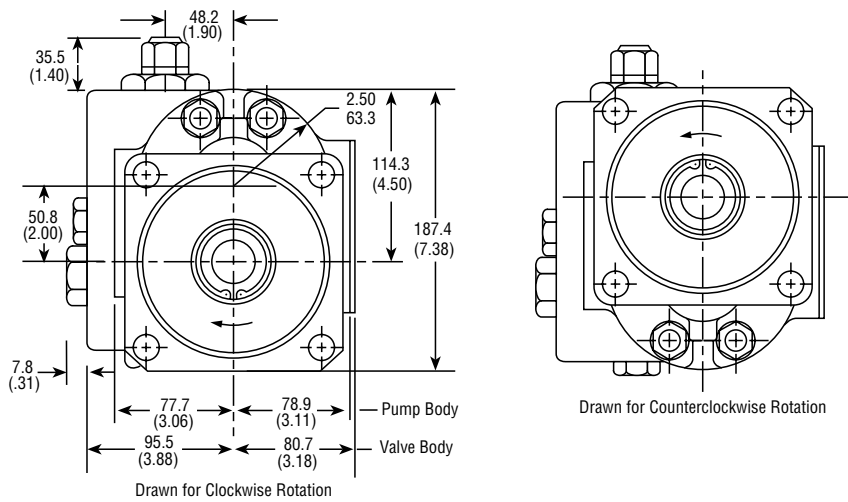

**Specifications
 for NDS20 Series**

Description Pressure-Summation Unloading Gear Pumps
 Combined Flow Range To 98 GPM Per Section (370.9 LTR.)
 Displacements To 9.10 C.I.R. Each Section(149.12 CC's/REV.)
 Maximum Pressure to 2500 PSI (172 BAR)
 Maximum Speed to 2500 RPM
 Rotation A or C
 Bearings Journal
 Construction Aluminum

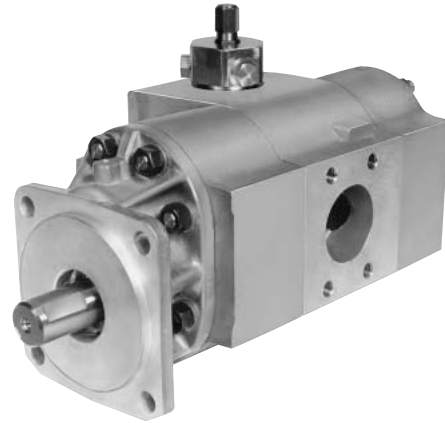

**Tandem Pump with Pressure-Summation
 Unloading Valve**

The NDS pump system is essentially the same as the NSH system, except the unloading pressure signal is the summation of the internal pressure, plus an external pressure from another pumping system. The NDS system is useful in limiting the horsepower withdrawn from the prime mover in a multiple pump circuit system.

If System B is operating at minimum pressure, then the NDS circuit (System A) can operate at a high pressure-high flow before unloading the rear pumping section.

If System B is operating at high pressure, then the NDS circuit (System A) would unload the rear pumping section at a lower pressure to avoid overloading the engine. This relationship can be seen in the chart which illustrates the unloading characteristics for the NDS system, when used in conjunction with another hydraulic pump (system B).

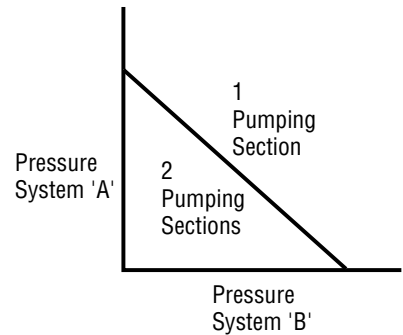
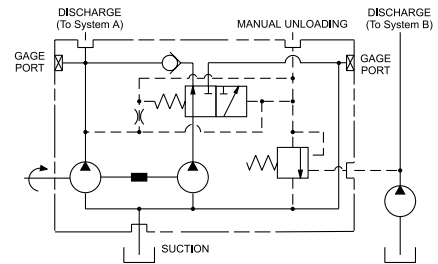

Performance Data Per Section

Pump Model	Section Size	Displacement/Revolution (Theoretical)					Maximum Pressure		Maximum Speed
		US Gallons	Cubic Inches	Liters	Cubic Centimeters	Imperial Gallons	PSI	BAR	
NDS20	150	.0131	3.02	.0496	49.849	.0108	2500	172	2500
NDS20	200	.0175	4.04	.0662	66.204	.0146	2500	172	2500
NDS20	250	.0219	5.06	.0829	82.919	.0182	2500	172	2500
NDS20	300	.0262	6.05	.0992	99.142	.0218	2500	172	2500
NDS20	350	.0306	7.07	.1158	115.857	.0255	2500	172	2500
NDS20	400	.0350	8.08	.1325	132.408	.0292	2500	172	2500
NDS20	450	.0394	9.10	.1491	149.123	.0328	2500	172	2500

All data based on SAE 10W oil at 150°F. Available with Viton® Seals.



CAUTION: "Inlet vacuum" should not exceed 5" Hg at normal operating speed and temperature. Operation of pumps in excess of 5" Hg requires factory approval.

Dimensional Data

MOUNTING DIMENSIONS								
FRONT SECTION SIZE	REAR SECTION SIZE	CONN. SIZE	DISCHARGE FRONT SECTION HOLE DIA.	MOUNTING DIMENSIONS			SHIPPING WEIGHTS	
				A	B	C	lbs.	kgs.
20150	—150	1"	23.6 (.93)	91.4 (3.60)	179.5 (7.07)	322.0 (12.68)	56	20.9
	—200	1"	23.6 (.93)	91.4 (3.60)	179.5 (7.07)	343.9 (13.54)	57	21.3
	—250	1"	23.6 (.93)	91.4 (3.60)	179.5 (7.07)	353.8 (13.93)	58	21.7
	—300	1"	23.6 (.93)	91.4 (3.60)	179.5 (7.07)	361.1 (14.22)	60	22.4
	—350	1"	23.6 (.93)	91.4 (3.60)	179.5 (7.07)	351.2 (13.83)	62	23.1
	—400	1"	23.6 (.93)	91.4 (3.60)	179.5 (7.07)	358.3 (14.11)	64	23.9
	—450	1"	23.6 (.93)	91.4 (3.60)	179.5 (7.07)	365.7 (14.40)	66	24.6
20200	—150	1-1/2"	30.2 (1.19)	95.2 (3.75)	202.4 (7.97)	344.9 (13.58)	58	21.7
	—200	1-1/2"	30.2 (1.19)	95.2 (3.75)	202.4 (7.97)	366.7 (14.44)	59	22.0
	—250	1-1/2"	30.2 (1.19)	95.2 (3.75)	202.4 (7.97)	376.3 (14.83)	60	22.4
	—300	1-1/2"	30.2 (1.19)	95.2 (3.75)	202.4 (7.97)	383.7 (15.11)	62	23.1
	—350	1-1/2"	30.2 (1.19)	95.2 (3.75)	202.4 (7.97)	373.8 (14.72)	64	23.9
	—400	1-1/2"	30.2 (1.19)	95.2 (3.75)	202.4 (7.97)	381.0 (15.00)	66	24.6
	—450	1-1/2"	30.2 (1.19)	95.2 (3.75)	202.4 (7.97)	388.3 (15.29)	68	25.4
20250	—150	1-1/2"	30.2 (1.19)	101.6 (4.00)	209.5 (8.25)	352.0 (13.86)	59	21.7
	—200	1-1/2"	30.2 (1.19)	101.6 (4.00)	209.5 (8.25)	373.6 (14.71)	60	22.4
	—250	1-1/2"	30.2 (1.19)	101.6 (4.00)	209.5 (8.25)	383.7 (15.11)	62	23.1
	—300	1-1/2"	30.2 (1.19)	101.6 (4.00)	209.5 (8.25)	390.9 (15.39)	64	23.9
	—350	1-1/2"	30.2 (1.19)	101.6 (4.00)	209.5 (8.25)	381.0 (15.00)	66	24.6
	—400	1-1/2"	30.2 (1.19)	101.6 (4.00)	209.5 (8.25)	388.1 (15.28)	68	25.4
	—450	1-1/2"	30.2 (1.19)	101.6 (4.00)	209.5 (8.25)	395.4 (15.57)	70	26.1
20300	—150	1-1/2"	30.2 (1.19)	105.1 (4.14)	216.9 (8.54)	359.4 (14.15)	60	22.4
	—200	1-1/2"	30.2 (1.19)	105.1 (4.14)	216.9 (8.54)	381.0 (15.00)	64	23.9
	—250	1-1/2"	30.2 (1.19)	105.1 (4.14)	216.9 (8.54)	391.1 (15.40)	66	24.6
	—300	1-1/2"	30.2 (1.19)	105.1 (4.14)	216.9 (8.54)	398.2 (15.68)	68	25.4
	—350	1-1/2"	30.2 (1.19)	105.1 (4.14)	216.9 (8.54)	388.3 (15.29)	70	26.1
	—400	1-1/2"	30.2 (1.19)	105.1 (4.14)	216.9 (8.54)	395.4 (15.57)	72	26.9
	—450	1-1/2"	30.2 (1.19)	105.1 (4.14)	216.9 (8.54)	402.8 (15.86)	74	27.6
20350	—150	1-1/2"	30.2 (1.19)	110.4 (4.35)	224.0 (8.82)	366.5 (14.43)	62	23.1
	—200	1-1/2"	30.2 (1.19)	110.4 (4.35)	224.0 (8.82)	388.1 (15.28)	64	23.9
	—250	1-1/2"	30.2 (1.19)	110.4 (4.35)	224.0 (8.82)	398.2 (15.68)	66	24.6
	—300	1-1/2"	30.2 (1.19)	110.4 (4.35)	224.0 (8.82)	405.3 (15.96)	70	26.1
	—350	1-1/2"	30.2 (1.19)	110.4 (4.35)	224.0 (8.82)	395.4 (15.57)	72	26.9
	—400	1-1/2"	30.2 (1.19)	110.4 (4.35)	224.0 (8.82)	402.5 (15.85)	74	27.6
	—450	1-1/2"	30.2 (1.19)	110.4 (4.35)	224.0 (8.82)	409.9 (16.14)	76	28.4
20400	—150	1-1/2"	34.7 (1.37)	110.4 (4.35)	231.1 (9.10)	373.6 (14.71)	64	23.9
	—200	1-1/2"	34.7 (1.37)	110.4 (4.35)	231.1 (9.10)	395.2 (15.56)	66	24.6
	—250	1-1/2"	34.7 (1.37)	110.4 (4.35)	231.1 (9.10)	405.3 (15.96)	68	25.4
	—300	1-1/2"	34.7 (1.37)	110.4 (4.35)	231.1 (9.10)	412.4 (16.24)	70	26.1
	—350	1-1/2"	34.7 (1.37)	110.4 (4.35)	231.1 (9.10)	402.5 (15.85)	72	26.9
	—400	1-1/2"	34.7 (1.37)	110.4 (4.35)	231.1 (9.10)	409.7 (16.13)	76	28.4
	—450	1-1/2"	34.7 (1.37)	110.4 (4.35)	231.1 (9.10)	417.0 (16.42)	78	29.1
20450	—150	1-1/2"	34.7 (1.37)	118.3 (4.66)	238.5 (9.39)	381.0 (15.00)	66	24.6
	—200	1-1/2"	34.7 (1.37)	118.3 (4.66)	238.5 (9.39)	402.5 (15.85)	68	25.4
	—250	1-1/2"	34.7 (1.37)	118.3 (4.66)	238.5 (9.39)	412.7 (16.25)	70	26.1
	—300	1-1/2"	34.7 (1.37)	118.3 (4.66)	238.5 (9.39)	419.8 (16.53)	74	27.6
	—350	1-1/2"	34.7 (1.37)	118.3 (4.66)	238.5 (9.39)	409.9 (16.14)	76	28.4
	—400	1-1/2"	34.7 (1.37)	118.3 (4.66)	238.5 (9.39)	417.0 (16.42)	78	29.1
	—450	1-1/2"	34.7 (1.37)	118.3 (4.66)	238.5 (9.39)	424.4 (16.71)	80	29.9

SAE 4-BOLT CONNECTOR PORTS					
Size	F	G	H	J	K
1"	12.9 (.51)	26.1 (1.03)	26.1 (1.03)	52.3 (2.06)	3/8-16NC
1-1/2"	17.7 (.70)	35.5 (1.40)	34.7 (1.37)	69.8 (2.75)	1/2-13NC
2-1/2"	25.4 (1.00)	50.8 (2.00)	44.4 (1.75)	88.9 (3.50)	1/2-13NC

Dimensional Data

Inch equivalents for millimeter dimensions are shown in (**).

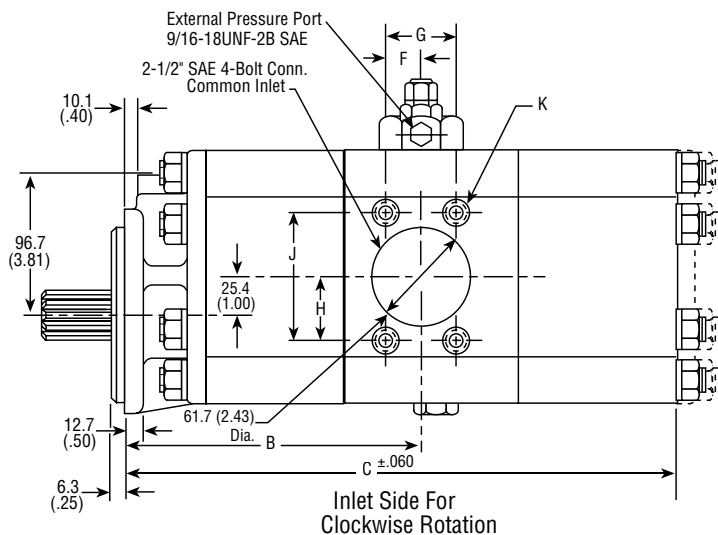
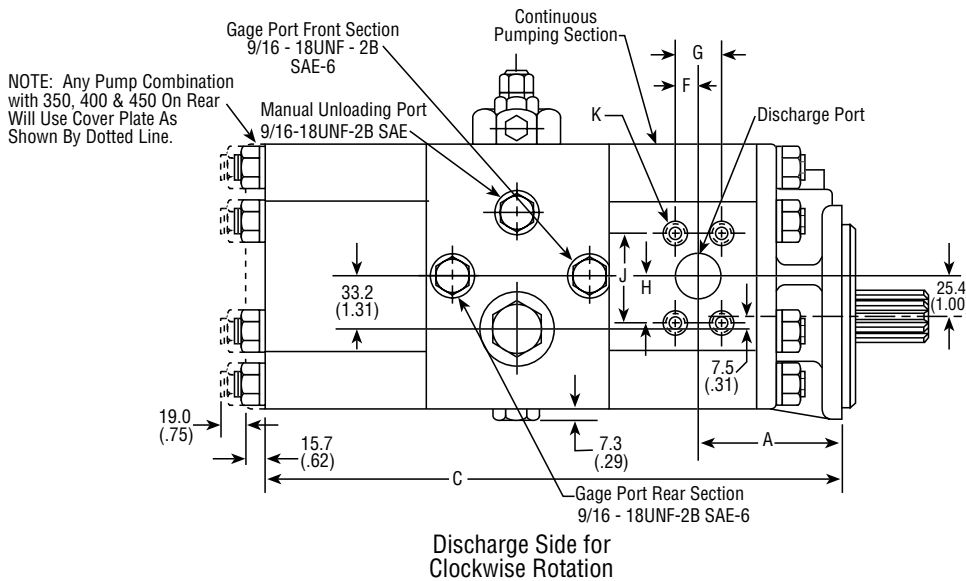
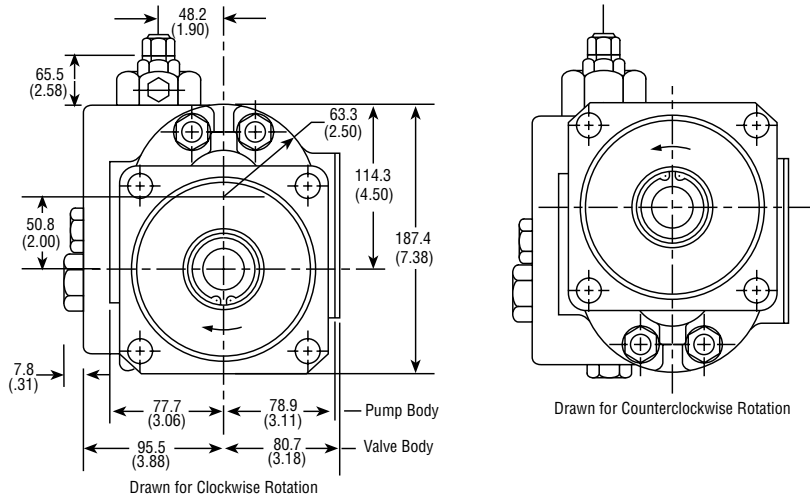

**Specifications
 for NSHD20 Series**

Description..... Flow-Sensing and Pressure-Sensing
 Unloading Gear Pumps

Combined Flow Range To 98 GPM Per Section (370.9 LTR)

Displacements To 9.10 C.I.R. Each Section (149.12 CC's/REV.)

Maximum Pressure to 2500 PSI (172 BAR)

Maximum Speed to 2500 RPM

Rotation A or C

Bearings..... Journal

Construction Aluminum

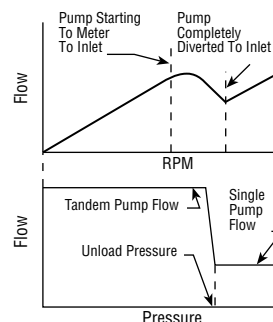
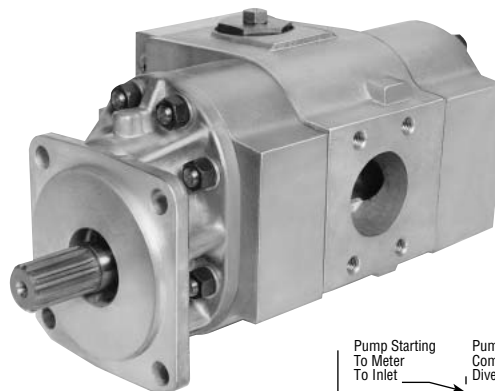

**Tandem Pump with Flow-Sensing and
 Pressure-Sensing Unloading Valve**

This system consists of a tandem pump and an unloading valve. The unloading valve is actuated by either a flow signal (pump speed) or a pressure signal, thus combining the features of the NST and NSH systems into a single system.

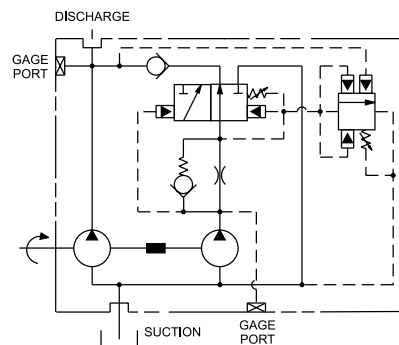

Performance Data Per Section

Pump Model	Section Size	Displacement/Revolution (Theoretical)					Maximum Pressure		Maximum Speed
		US Gallons	Cubic Inches	Liters	Cubic Centimeters	Imperial Gallons	PSI	BAR	RPM
NSHD20	150	.0131	3.02	.0496	49.849	.0108	2500	172	2500
NSHD20	200	.0175	4.04	.0662	66.204	.0146	2500	172	2500
NSHD20	250	.0219	5.06	.0829	82.919	.0182	2500	172	2500
NSHD20	300	.0262	6.05	.0992	99.142	.0218	2500	172	2500
NSHD20	350	.0306	7.07	.1158	115.857	.0255	2500	172	2500
NSHD20	400	.0350	8.08	.1325	132.408	.0292	2500	172	2500
NSHD20	450	.0394	9.10	.1491	149.123	.0328	2500	172	2500

All data based on SAE 10W oil at 150°F. Available with Viton® Seals.



CAUTION: "Inlet vacuum" should not exceed 5" Hg at normal operating speed and temperature. Operation of pumps in excess of 5" Hg requires factory approval.

Dimensional Data

MOUNTING DIMENSIONS									
FRONT SECTION SIZE	REAR SECTION SIZE	CONN. SIZE	DISCHARGE FRNT. SCTN. HOLE DIA.					SHIPPINGWEIGHTS	
				A	B	C	D	lbs.	kgs.
20150	—150	1"	23.6 (.93)	91.4 (3.60)	179.5 (7.07)	322.0 (12.68)	133.8 (5.27)	56	20.9
	—200	1"	23.6 (.93)	91.4 (3.60)	179.5 (7.07)	343.9 (13.54)	133.8 (5.27)	57	21.3
	—250	1"	23.6 (.93)	91.4 (3.60)	179.5 (7.07)	353.8 (13.93)	133.8 (5.27)	58	21.7
	—300	1"	23.6 (.93)	91.4 (3.60)	179.5 (7.07)	361.1 (14.22)	133.8 (5.27)	60	22.4
	—350	1"	23.6 (.93)	91.4 (3.60)	179.5 (7.07)	351.2 (13.83)	133.8 (5.27)	62	23.1
	—400	1"	23.6 (.93)	91.4 (3.60)	179.5 (7.07)	358.3 (14.11)	133.8 (5.27)	64	23.9
	—450	1"	23.6 (.93)	91.4 (3.60)	179.5 (7.07)	365.7 (14.40)	133.8 (5.27)	66	24.6
20200	—150	1-1/2"	30.2 (1.19)	95.2 (3.75)	202.4 (7.97)	344.9 (13.58)	156.7 (6.17)	58	21.7
	—200	1-1/2"	30.2 (1.19)	95.2 (3.75)	202.4 (7.97)	366.7 (14.44)	156.7 (6.17)	59	22.0
	—250	1-1/2"	30.2 (1.19)	95.2 (3.75)	202.4 (7.97)	376.3 (14.83)	156.7 (6.17)	60	22.4
	—300	1-1/2"	30.2 (1.19)	95.2 (3.75)	202.4 (7.97)	383.7 (15.11)	156.7 (6.17)	62	23.1
	—350	1-1/2"	30.2 (1.19)	95.2 (3.75)	202.4 (7.97)	373.8 (14.72)	156.7 (6.17)	64	23.9
	—400	1-1/2"	30.2 (1.19)	95.2 (3.75)	202.4 (7.97)	381.0 (15.00)	156.7 (6.17)	66	24.6
	—450	1-1/2"	30.2 (1.19)	95.2 (3.75)	202.4 (7.97)	388.3 (15.29)	156.7 (6.17)	68	25.4
20250	—150	1-1/2"	30.2 (1.19)	101.6 (4.00)	209.5 (8.25)	352.0 (13.86)	163.8 (6.45)	59	21.7
	—200	1-1/2"	30.2 (1.19)	101.6 (4.00)	209.5 (8.25)	373.6 (14.71)	163.8 (6.45)	60	22.4
	—250	1-1/2"	30.2 (1.19)	101.6 (4.00)	209.5 (8.25)	383.7 (15.11)	163.8 (6.45)	62	23.1
	—300	1-1/2"	30.2 (1.19)	101.6 (4.00)	209.5 (8.25)	390.9 (15.39)	163.8 (6.45)	64	23.9
	—350	1-1/2"	30.2 (1.19)	101.6 (4.00)	209.5 (8.25)	381.0 (15.00)	163.8 (6.45)	66	24.6
	—400	1-1/2"	30.2 (1.19)	101.6 (4.00)	209.5 (8.25)	388.1 (15.28)	163.8 (6.45)	68	25.4
	—450	1-1/2"	30.2 (1.19)	101.6 (4.00)	209.5 (8.25)	395.4 (15.57)	163.8 (6.45)	70	26.1
20300	—150	1-1/2"	30.2 (1.19)	105.1 (4.14)	216.9 (8.54)	359.4 (14.15)	171.1 (6.74)	60	22.4
	—200	1-1/2"	30.2 (1.19)	105.1 (4.14)	216.9 (8.54)	381.0 (15.00)	171.1 (6.74)	64	23.9
	—250	1-1/2"	30.2 (1.19)	105.1 (4.14)	216.9 (8.54)	391.1 (15.40)	171.1 (6.74)	66	24.6
	—300	1-1/2"	30.2 (1.19)	105.1 (4.14)	216.9 (8.54)	398.2 (15.68)	171.1 (6.74)	68	25.4
	—350	1-1/2"	30.2 (1.19)	105.1 (4.14)	216.9 (8.54)	388.3 (15.29)	171.1 (6.74)	70	26.1
	—400	1-1/2"	30.2 (1.19)	105.1 (4.14)	216.9 (8.54)	395.4 (15.57)	171.1 (6.74)	72	26.9
	—450	1-1/2"	30.2 (1.19)	105.1 (4.14)	216.9 (8.54)	402.8 (15.86)	171.1 (6.74)	74	27.6
20350	—150	1-1/2"	30.2 (1.19)	110.4 (4.35)	224.0 (8.82)	366.5 (14.43)	178.3 (7.02)	62	23.1
	—200	1-1/2"	30.2 (1.19)	110.4 (4.35)	224.0 (8.82)	388.1 (15.28)	178.3 (7.02)	64	23.9
	—250	1-1/2"	30.2 (1.19)	110.4 (4.35)	224.0 (8.82)	398.2 (15.68)	178.3 (7.02)	66	24.6
	—300	1-1/2"	30.2 (1.19)	110.4 (4.35)	224.0 (8.82)	405.3 (15.96)	178.3 (7.02)	70	26.1
	—350	1-1/2"	30.2 (1.19)	110.4 (4.35)	224.0 (8.82)	395.4 (15.57)	178.3 (7.02)	72	26.9
	—400	1-1/2"	30.2 (1.19)	110.4 (4.35)	224.0 (8.82)	402.5 (15.85)	178.3 (7.02)	74	27.6
	—450	1-1/2"	30.2 (1.19)	110.4 (4.35)	224.0 (8.82)	409.9 (16.14)	178.3 (7.02)	76	28.4
20400	—150	1-1/2"	34.7 (1.37)	110.4 (4.35)	231.1 (9.10)	373.6 (14.71)	185.4 (7.30)	64	23.9
	—200	1-1/2"	34.7 (1.37)	110.4 (4.35)	231.1 (9.10)	395.2 (15.56)	185.4 (7.30)	66	24.6
	—250	1-1/2"	34.7 (1.37)	110.4 (4.35)	231.1 (9.10)	405.3 (15.96)	185.4 (7.30)	68	25.4
	—300	1-1/2"	34.7 (1.37)	110.4 (4.35)	231.1 (9.10)	412.4 (16.24)	185.4 (7.30)	70	26.1
	—350	1-1/2"	34.7 (1.37)	110.4 (4.35)	231.1 (9.10)	402.5 (15.85)	185.4 (7.30)	72	26.9
	—400	1-1/2"	34.7 (1.37)	110.4 (4.35)	231.1 (9.10)	409.7 (16.13)	185.4 (7.30)	76	28.4
	—450	1-1/2"	34.7 (1.37)	110.4 (4.35)	231.1 (9.10)	417.0 (16.42)	185.4 (7.30)	78	29.1
20450	—150	1-1/2"	34.7 (1.37)	118.3 (4.66)	238.5 (9.39)	381.0 (15.00)	192.7 (7.59)	66	24.6
	—200	1-1/2"	34.7 (1.37)	118.3 (4.66)	238.5 (9.39)	402.5 (15.85)	192.7 (7.59)	68	25.4
	—250	1-1/2"	34.7 (1.37)	118.3 (4.66)	238.5 (9.39)	412.7 (16.25)	192.7 (7.59)	70	26.1
	—300	1-1/2"	34.7 (1.37)	118.3 (4.66)	238.5 (9.39)	419.8 (16.53)	192.7 (7.59)	74	27.6
	—350	1-1/2"	34.7 (1.37)	118.3 (4.66)	238.5 (9.39)	409.9 (16.14)	192.7 (7.59)	76	28.4
	—400	1-1/2"	34.7 (1.37)	118.3 (4.66)	238.5 (9.39)	417.0 (16.42)	192.7 (7.59)	78	29.1
	—450	1-1/2"	34.7 (1.37)	118.3 (4.66)	238.5 (9.39)	424.4 (16.71)	192.7 (7.59)	80	29.9

Dimensional Data

Inch equivalents for millimeter dimensions are shown in (**).

SAE 4-BOLT CONNECTOR PORTS					
Size	F	G	H	J	K
1"	12.9 (.51)	26.1 (1.03)	26.1 (1.03)	52.3 (2.06)	3/8-16NC
1-1/2"	17.7 (.70)	35.5 (1.40)	34.7 (1.37)	69.8 (2.75)	1/2-13NC
2-1/2"	25.4 (1.00)	50.8 (2.00)	44.4 (1.75)	88.9 (3.50)	1/2-13NC

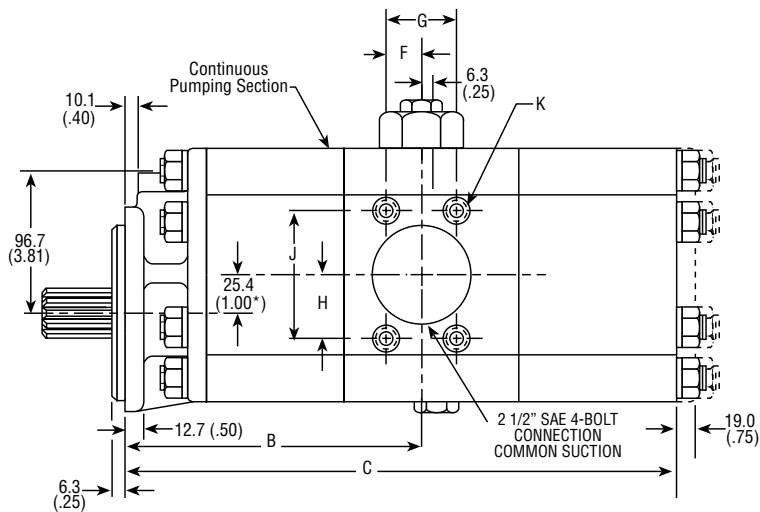
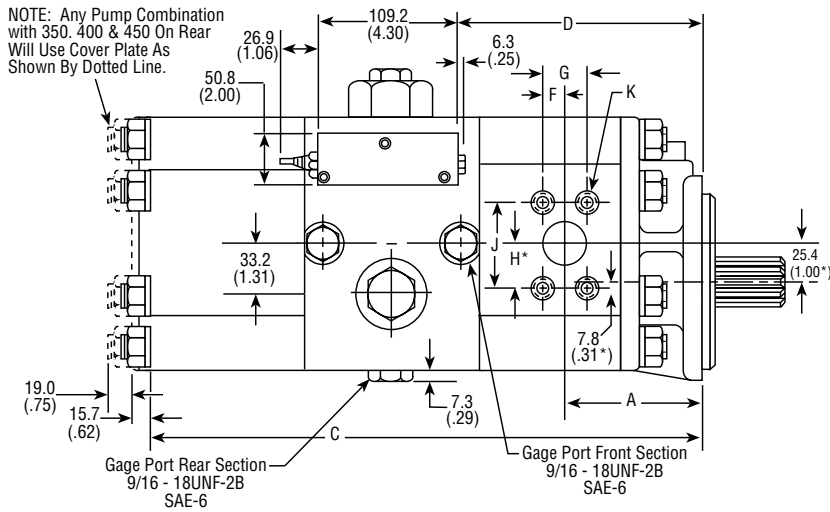
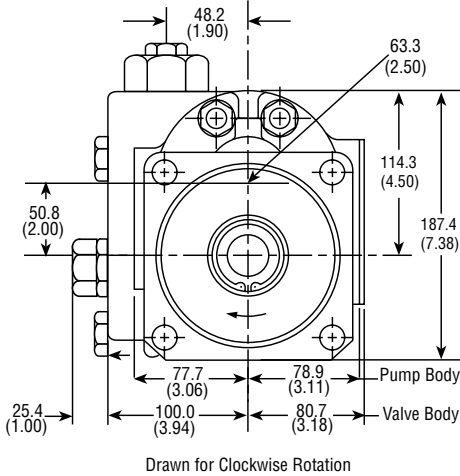
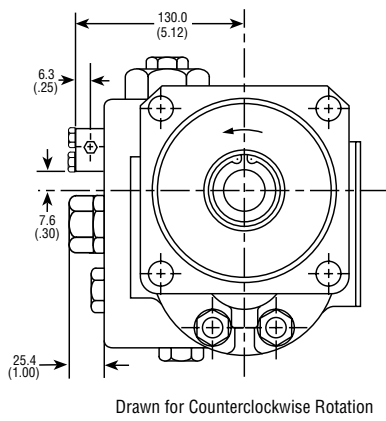

**Specifications
 for PSH20 Series**

Description Air-Actuated Unloading Pump
 Combined Flow Range ... To 98 GPM Per Selection (370.9 LTR.)
 Displacements... To 9.10 C.I.R. Each Section (149.12 CC's/REV.)
 Maximum Pressure to 2500 PSI (172 BAR)
 Maximum Speed to 2500 RPM
 Rotation A or C
 Bearings Journal
 Construction Aluminum

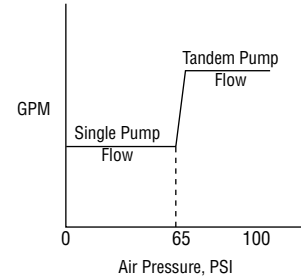

Tandem Pump With Air-Actuated Unloading Valve

This tandem pump with air-actuated unloading valve is commonly used to select either the combined flow rate of both pump sections. or the flow rate of only one pump section.

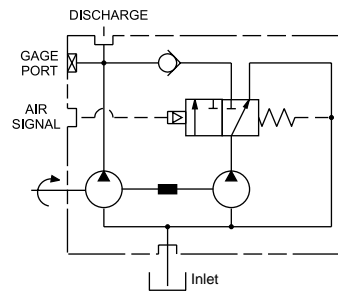

Performance Data Per Section

Pump Model	Section Size	Displacement/Revolution (Theoretical)					Maximum Pressure		Maximum Speed
		US Gallons	Cubic Inches	Liters	Cubic Centimeters	Imperial Gallons	PSI	BAR	
PSH20	150	.0131	3.02	.0496	49.489	.0108	2500	172	2500
PSH20	200	.0175	4.04	.0662	66.204	.0146	2500	172	2500
PSH20	250	.0219	5.06	.0829	82.919	.0182	2500	172	2500
PSH20	300	.0262	6.05	.0992	99.142	.0218	2500	172	2500
PSH20	350	.0306	7.07	.1158	115.857	.0255	2500	172	2500
PSH20	400	.0350	8.08	.1325	132.408	.0292	2500	172	2500
PSH20	450	.0394	9.10	.1491	149.123	.0328	2500	172	2500

All data based on SAE 10W oil at 150°F. Available with Viton® Seals.



CAUTION: "Inlet vacuum" should not exceed 5" Hg at normal operating speed and temperature. Operation of pumps in excess of 5" Hg requires factory approval.

Dimensional Data

MOUNTING DIMENSIONS								
FRONT SECTION SIZE	REAR SECTION SIZE	CONN. SIZE	DISCHARGE FRONT SECTION HOLE DIA.	MOUNTING DIMENSIONS			SHIPPING WEIGHTS	
				A	B	C	lbs.	kgs.
20150	—150	1"	23.6 (.93)	91.4 (3.60)	195.0 (7.68)	352.0 (13.86)	56	20.9
	—200	1"	23.6 (.93)	91.4 (3.60)	195.0 (7.68)	371.8 (14.64)	57	21.3
	—250	1"	23.6 (.93)	91.4 (3.60)	195.0 (7.68)	382.0 (15.04)	58	21.7
	—300	1"	23.6 (.93)	91.4 (3.60)	195.0 (7.68)	389.1 (15.32)	60	22.4
	—350	1"	23.6 (.93)	91.4 (3.60)	195.0 (7.68)	379.2 (14.93)	62	23.1
	—400	1"	23.6 (.93)	91.4 (3.60)	195.0 (7.68)	386.3 (15.21)	64	23.9
—450	1"	23.6 (.93)	91.4 (3.60)	195.0 (7.68)	393.7 (15.50)	66	24.6	
20200	—200	1-1/2"	30.2 (1.19)	95.2 (3.75)	215.1 (8.47)	391.9 (15.43)	59	22.0
	—250	1-1/2"	30.2 (1.19)	95.2 (3.75)	215.1 (8.47)	402.0 (15.83)	60	22.4
	—300	1-1/2"	30.2 (1.19)	95.2 (3.75)	215.1 (8.47)	409.1 (16.11)	62	23.1
	—350	1-1/2"	30.2 (1.19)	95.2 (3.75)	215.1 (8.47)	399.2 (15.72)	64	23.9
	—400	1-1/2"	30.2 (1.19)	95.2 (3.75)	215.1 (8.47)	406.4 (16.00)	66	24.6
	—450	1-1/2"	30.2 (1.19)	95.2 (3.75)	215.1 (8.47)	413.7 (16.29)	68	25.4
20250	—250	1-1/2"	30.2 (1.19)	101.6 (4.00)	222.2 (8.75)	409.1 (16.11)	62	23.1
	—300	1-1/2"	30.2 (1.19)	101.6 (4.00)	222.2 (8.75)	416.3 (16.39)	64	23.9
	—350	1-1/2"	30.2 (1.19)	101.6 (4.00)	222.2 (8.75)	406.4 (16.00)	66	24.6
	—400	1-1/2"	30.2 (1.19)	101.6 (4.00)	222.2 (8.75)	413.5 (16.28)	68	25.4
	—450	1-1/2"	30.2 (1.19)	101.6 (4.00)	222.2 (8.75)	420.8 (16.57)	70	26.1
20300	—300	1-1/2"	30.2 (1.19)	105.1 (4.14)	229.3 (9.03)	423.4 (16.67)	68	25.4
	—350	1-1/2"	30.2 (1.19)	105.1 (4.14)	229.3 (9.03)	413.5 (16.28)	70	26.1
	—400	1-1/2"	30.2 (1.19)	105.1 (4.14)	229.3 (9.03)	420.6 (16.56)	72	26.9
	—450	1-1/2"	30.2 (1.19)	105.1 (4.14)	229.3 (9.03)	427.9 (16.85)	74	27.6
20350	—350	1-1/2"	30.2 (1.19)	110.4 (4.35)	236.7 (9.32)	420.8 (16.57)	72	26.9
	—400	1-1/2"	30.2 (1.19)	110.4 (4.35)	236.7 (9.32)	427.9 (16.85)	74	27.6
	—450	1-1/2"	30.2 (1.19)	110.4 (4.35)	236.7 (9.32)	435.3 (17.14)	76	28.4
20400	—400	1-1/2"	34.7 (1.37)	110.4 (4.35)	243.8 (9.60)	435.1 (17.13)	76	28.4
	—450	1-1/2"	34.7 (1.37)	110.4 (4.35)	243.8 (9.60)	442.4 (17.42)	78	29.1
20450	—450	1-1/2"	34.7 (1.37)	118.3 (4.66)	251.2 (9.89)	449.8 (17.71)	80	29.9

SAE 4-BOLT CONNECTOR PORTS					
Size	F	G	H	J	K
1"	12.9 (.51)	26.1 (1.03)	26.1 (1.03)	52.3 (2.06)	3/8-16NC
1-1/2"	17.7 (.70)	35.5 (1.40)	34.7 (1.37)	69.8 (2.75)	1/2-13NC
2-1/2"	25.4 (1.00)	50.8 (2.00)	44.4 (1.75)	88.9 (3.50)	1/2-13NC

Inch equivalents for millimeter dimensions are shown in (**).

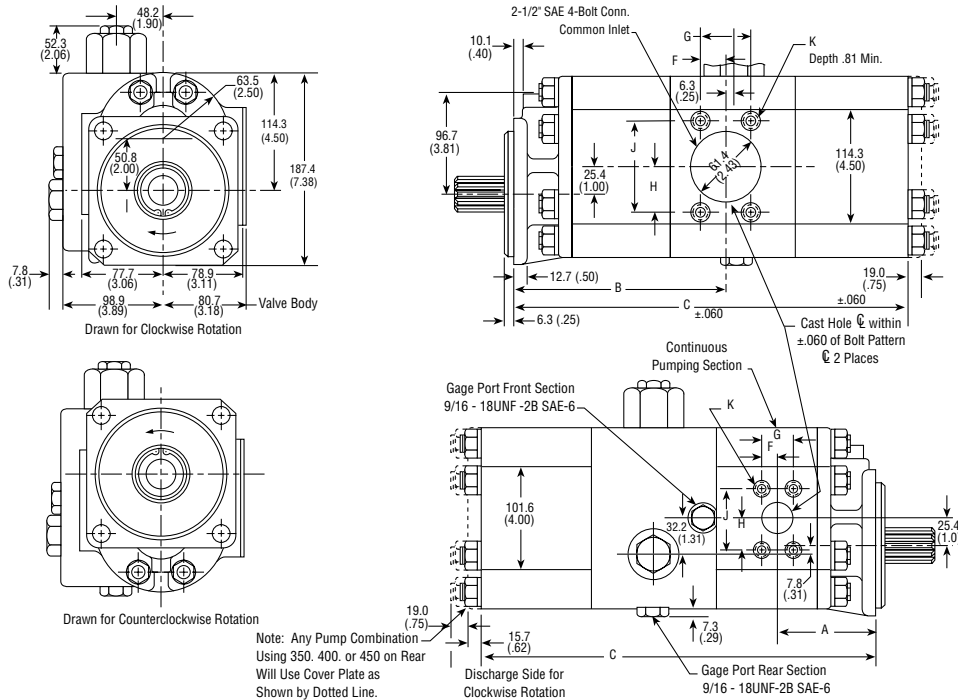

Shafts Available for 20 Series

Inch equivalents for millimeter dimensions are shown in (**).

<p>1 SAE 'C' 1-1/4" 14-Tooth Spline Flat Root Side Fit Torque limit 655 Lbs. Ft. (888. Nm) Available in all sizes.</p> <p>"Single" Pumps only "Tandem" Pumps only</p> <p>Spline Data Diametral Pitch 12/24 Pressure Angle 30° No. Of Teeth 14</p>	<p>2 1" Dia. Straight Shaft Torque limit 341 Lbs. Ft. (462.3 Nm)</p> <p>CAUTION: Due to shaft torque limitations. Consult the Factory for approval before applying this shaft in models of -350 size and larger pumps. Not available for tandem pumps.</p>	<p>3 SAE 'C' 1-1/4" 14 Straight Shaft Torque limit 655 Lbs. Ft. (888. Nm) Available on all sizes.</p>
<p>4 7/8" Dia. 13 Tooth Spline Flat Root Side Fit Torque limit 184 Lbs. Ft. (249.4 Nm)</p> <p>CAUTION: Due to shaft torque limitations. Consult the Factory for approval before applying this shaft in models of -350 size and larger pumps. Not available for tandem pumps.</p> <p>Spline Data Diametral Pitch 16/32 Pressure Angle 30° No. Of Teeth 13</p>	<p>5 1-1/4" Straight Shaft Torque limit 655 Lbs. Ft. (888. Nm) Available on all sizes</p>	

Mounting Flanges Available for 20 Series

<p>D SAE 'C' 4-Bolt</p>	<p>E SAE 'B' 4-Bolt</p>	<p>F SAE 'C' 2-Bolt</p>
<p>H 4-Bolt For P.T.O. Assembly 220 (SPL. 3.25 Pilot Dia.) Not Available for Tandem Pumps</p>	<p>M 'M' Pad Mount Not Available for Tandem Pumps</p>	<p>N SAE 'B' 2-Bolt</p>

Couplings Available for 20 Series Piggy Back Style

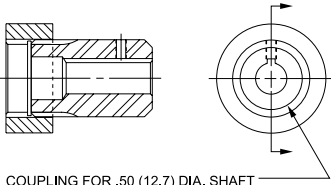
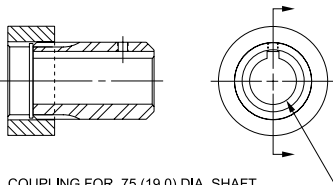
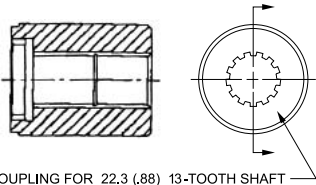
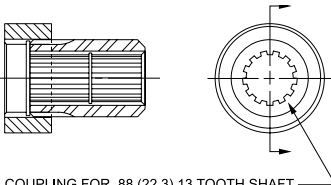
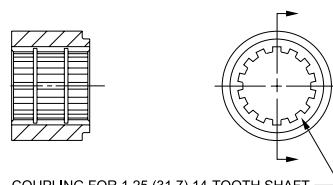
<p>50 1/2" Straight Kit No. 13974 with 1/8" Square Key</p>  <p>COUPLING FOR .50 (12.7) DIA. SHAFT WITH .125 (3.1) SQUARE KEY</p>	<p>75 3/4" Straight Kit No. 13975 with 3/16" Square Key</p>  <p>COUPLING FOR .75 (19.0) DIA. SHAFT WITH .19 (4.8) SQUARE KEY</p>	<p>88 7/8" 13 Tooth Kit No. 13976</p>  <p>COUPLING FOR 22.3 (.88) 13-TOOTH SHAFT</p> <p>Spline Data Diametral Pitch 16/32 Major Dia.875-.870 Minor Dia.7533-.7583</p>
<p>90 7/8" 13 Tooth Kit No. 13977</p>  <p>COUPLING FOR .88 (22.3) 13 TOOTH SHAFT</p> <p>Spline Data Diametral Pitch 16/32 Major Dia.875-.870 Minor Dia.7533-.7583</p>	<p>125 1-1/4" 14 Tooth Kit No. 13978</p>  <p>COUPLING FOR 1.25 (31.7) 14-TOOTH SHAFT</p> <p>Spline Data Diametral Pitch 16/32 Major Dia. 1.255-1.251 Minor Dia. 1.086-1.091</p>	<p>Inch equivalents for millimeter dimensions are shown in (**).</p>

Transition Plates Available for 20 Series Piggy Back Style

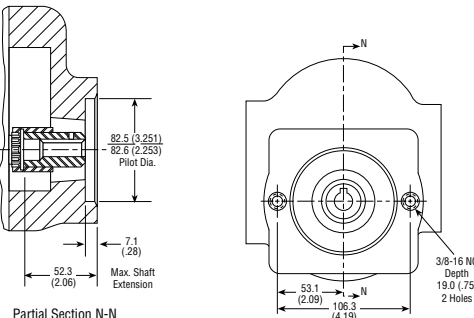
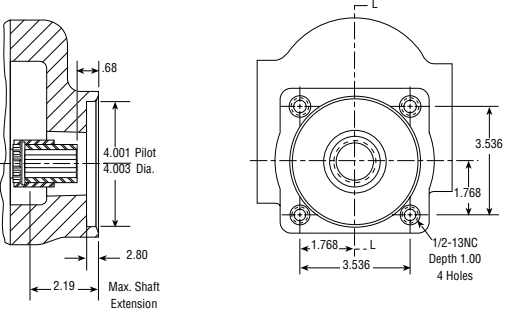
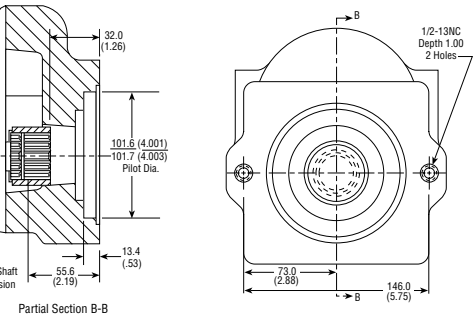
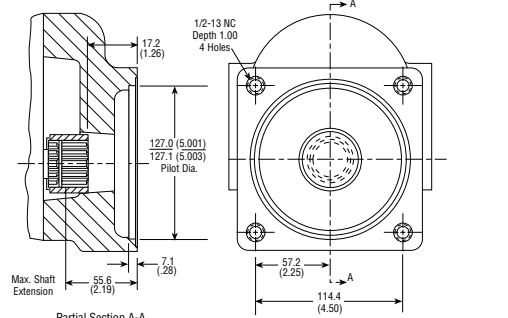
<p>A 2-Bolt 'A'—Shown with No. 50 Coupling</p>  <p>Partial Section N-N</p> <p>82.5 (3.251) Pilot Dia. 82.6 (2.253) 7.1 (.28) Max. Shaft Extension 52.3 (2.06) 53.1 (2.09) N 106.3 (4.19) N 3/8-16 NC Depth 19.0 (.75) 2 Holes</p>	<p>B 4-Bolt 'B'—Shown with No. 90 Coupling</p>  <p>Partial Section L-L</p> <p>68 4.001 Pilot 4.003 Dia. 2.80 2.19 Max. Shaft Extension 3.536 1.768 L 3.536 1/2-13NC Depth 1.00 4 Holes</p>
<p>C 2-Bolt 'B'—Shown with No. 125 Coupling</p>  <p>Partial Section B-B</p> <p>32.0 (1.26) 101.6 (4.001) Pilot Dia. 101.7 (4.003) 13.4 (.53) Max. Shaft Extension 55.6 (2.19) 73.0 (2.88) B 146.0 (5.75) B 1/2-13NC Depth 1.00 2 Holes</p>	<p>D 4-Bolt 'C'—Shown with No. 125 Coupling</p>  <p>Partial Section A-A</p> <p>17.2 (1.26) 127.0 (5.001) Pilot Dia. 127.1 (5.003) 7.1 (.28) Max. Shaft Extension 55.6 (2.19) 57.2 (2.25) A 114.4 (4.50) A 1/2-13 NC Depth 1.00 4 Holes</p>

General Information for 25 Series

- Available in various configurations:
 - 25 – Single Section
 - TP25 – Tandem. 2 & 3 Place
 - PB25 – Piggy-back design – allowing for additional pumps.
 - Constructions:
 - Aluminum – For excellent power to weight ratio
 - or
 - Cast iron – for extra durability*
 - Journal bearings for long life and good over-hung load capability
 - Buna-N Seals are standard for petroleum and glycol based fluids. “Viton®E” seals are optional.
 - Pressure balanced plates for greater efficiency.
- * Cast iron is not available on all models. Consult factory for availability.

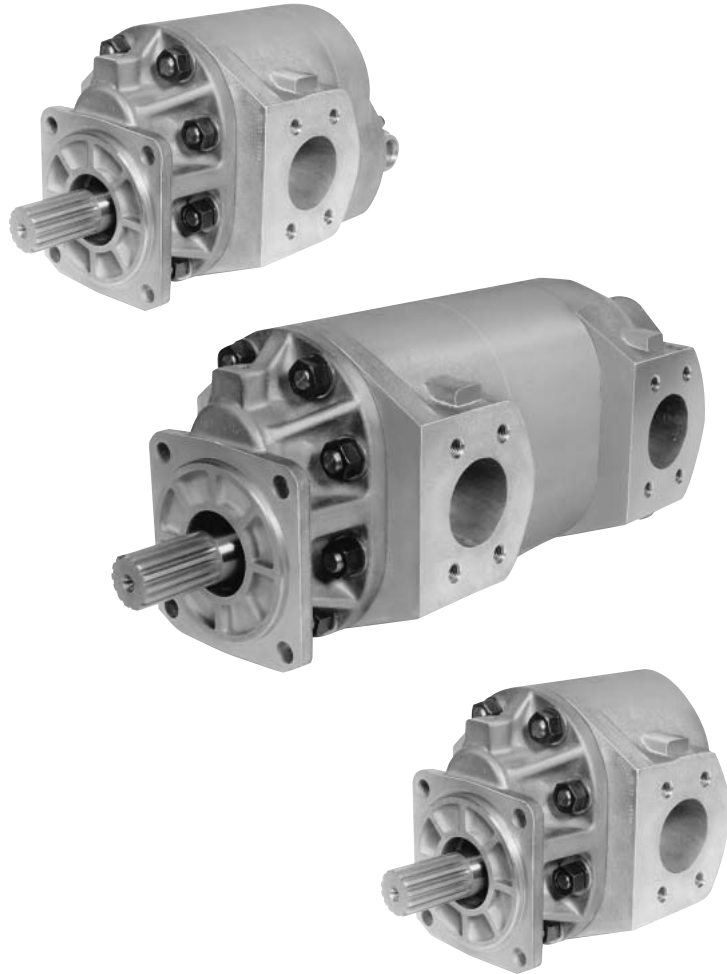

How to Order 25 Series:

Select the desired symbol (in the correct position) to construct a model code.

Assembly Example:

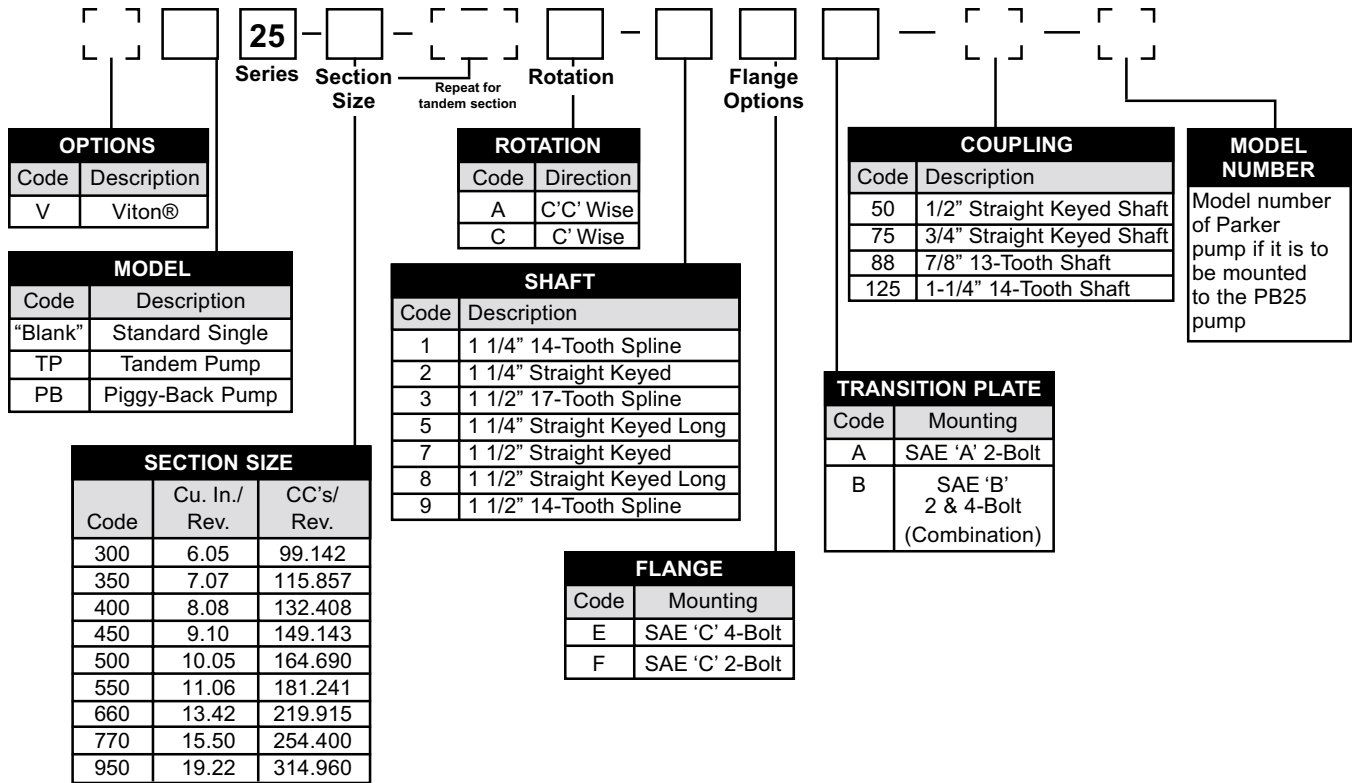

**Specifications
for 25 Series**

Description Gear Pumps
Flow Range To 208 GPM (787.3 LTR.)
Displacements To 19.22 C.I.R. (314.96 CC's/REV.)
Maximum Pressure to 3000 PSI (207 BAR)
Maximum Speed to 2500 RPM
Rotation A or C
Bearings Journal
Construction Aluminum
Cast Iron Available—Consult Factory

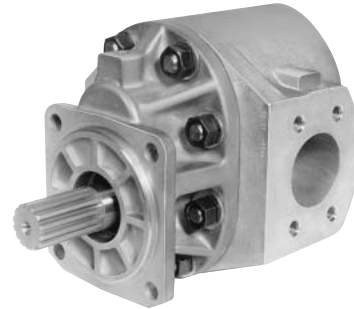

Performance Data

Pump Model	Section Size	Displacement/Revolution (Theoretical)					Maximum Pressure		Maximum Speed
		US Gallons	Cubic Inches	Liters	Cubic Centimeters	Imperial Gallons	PSI	BAR	RPM
25	300	.0262	6.05	.0992	99.142	.022	3000	207	2500
25	350	.0306	7.07	.1158	115.857	.025	3000	207	2500
25	400	.0350	8.08	.1324	132.408	.029	3000	207	2500
25	450	.0394	9.10	.1491	149.123	.033	3000	207	2500
25	500	.0435	10.05	.1647	164.690	.036	2500	172	2500
25	550	.0479	11.06	.1812	181.241	.040	2500	172	2500
25	660	.0581	13.42	.2200	219.915	.048	2500*	172*	2500
25	770	.0671	15.50	.2540	254.400	.056	2500*	172*	2500
25	950	.0832	19.22	.3150	314.960	.069	2500*	172*	2500

Available with Viton® Seals. All data based on SAE 10W oil at 150°F.
Cast-iron not available on all models. Consult factory for availability.
*Consult factory for application approval.



CAUTION: "Inlet vacuum" should not exceed 5" Hg at normal operating speed and temperature. Operation of pumps in excess of 5" Hg requires factory approval.

Dimensional Data

PUMP SIZE	MOUNTING DIMENSIONS							
	For 'C' 2-Bolt & 'C' 4-Bolt Flg.		SAE 4-Bolt Conn. Port		Conn. Hole Dia.		Shipping Weights	
	A	B	Suction	Disc.	Suction	Disc.	lbs.	kgs.
25300	128.5 (5.06)	223.7 (8.81)	2"	1-1/4"	50.8 (2.00)	31.7 (1.25)	41	18.60
25350	128.5 (5.06)	223.7 (8.81)	2"	1-1/4"	50.8 (2.00)	31.7 (1.25)	42	19.05
25400	128.5 (5.06)	223.7 (8.81)	2"	1-1/4"	50.8 (2.00)	31.7 (1.25)	43	19.50
25450	128.5 (5.06)	223.7 (8.81)	2"	1-1/4"	50.8 (2.00)	31.7 (1.25)	44	19.96
25500	123.9 (4.88)	219.2 (8.63)	2-1/2"	1-1/2"	63.5 (2.50)	38.1 (1.50)	45	20.41
25550	128.5 (5.06)	223.7 (8.81)	2-1/2"	1-1/2"	63.5 (2.50)	38.1 (1.50)	45	20.41
25660	34.8 (5.31)	230.1 (9.06)	2-1/2"	1-1/2"	63.5 (2.50)	38.1 (1.50)	46	20.87
25770	141.2 (5.56)	236.4 (9.31)	2-1/2"	1-1/2"	63.5 (2.50)	38.1 (1.50)	48	21.77
25950	157.7 (6.21)	252.7 (9.95)	3"	2"	76.2 (3.00)	50.8 (2.00)	49	22.23

SAE 4-Bolt Connector Ports								
Size	C	D	E	F	G	J		
						'A' Rotation	'C' Rotation	
1-1/4"	14.9 (.59)	30.1 (1.188)	29.2 (1.15)	58.7 (2.313)	7/16-14NC	38.1 (1.50)	25.4 (1.00)	
1-1/2"	17.7 (.70)	35.7 (1.406)	34.7 (1.37)	69.8 (2.750)	1/2-13NC	38.1 (1.50)	25.4 (1.00)	
2"	21.3 (.84)	42.8 (1.688)	38.8 (1.53)	77.7 (3.062)	1/2-13NC	38.1 (1.50)	25.4 (1.00)	
2-1/2"	25.4 (1.00)	50.8 (2.000)	44.4 (1.75)	88.9 (3.500)	1/2-13NC	38.1 (1.50)	25.4 (1.00)	
3"	30.7 (1.21)	61.9 (2.438)	53.0 (2.09)	106.3 (4.188)	5/8-11NC	38.1 (1.50)	25.4 (1.00)	

SAE 4-Bolt NPT Connectors are available. See Accessory Section

Inch equivalents for millimeter dimensions are shown in (**).

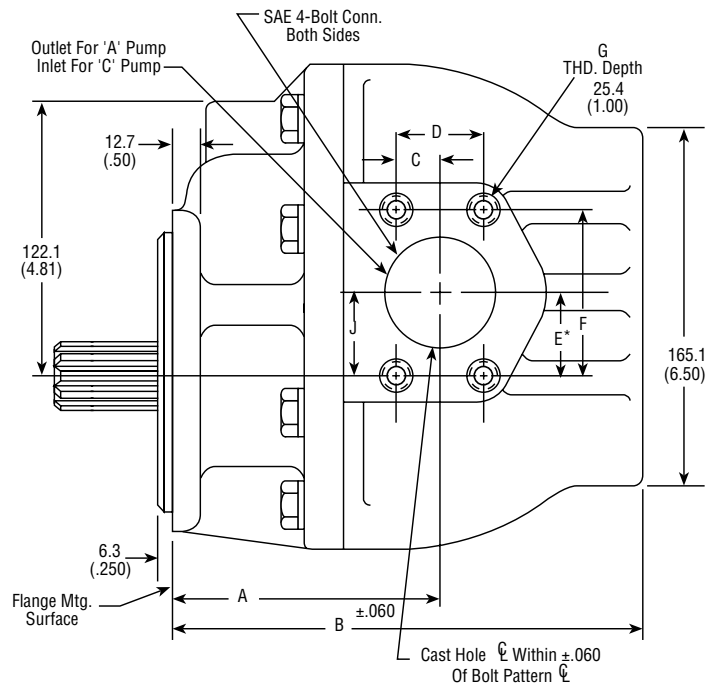

**Specifications
for TP25 Series**

Description Gear Pumps (Two-place)
Flow Range To 208 GPM Per Section (787.3 LTR)
Displacements To 19.22 C.I.R. each Section (319.96 cc's/rev.)
Maximum Pressure to 2500 PSI
Maximum Speed to 2500 RPM
Rotation A or C
Bearings Journal
Construction Aluminum
Cast Iron Available—Consult Factory



Performance Data Per Section

Pump Model	Section Size	Displacement/Revolution (Theoretical)					Maximum Pressure		Maximum Speed
		US Gallons	Cubic Inches	Liters	Cubic Centimeters	Imperial Gallons	PSI	BAR	RPM
TP25	550	.0479	11.06	.1812	181.241	.040	2500	172	2500
TP25	660	.0581	13.42	.2200	219.915	.048	2500*	172*	2500
TP25	770	.0671	15.50	.2540	254.400	.056	2500*	172*	2500
TP25	950	.0832	19.22	.3150	314.960	.069	2500*	172*	2500

Available with Viton® Seals. All data based on SAE 10W oil at 150°F.
Cast-iron not available on all models. Consult factory for availability.
*Consult factory for application approval.



CAUTION: "Inlet vacuum" should not exceed 5" Hg at normal operating speed and temperature. Operation of pumps in excess of 5" Hg requires factory approval.

Dimensional Data

MOUNTING DIMENSIONS									
PUMP SIZE	For 'C' 2-Bolt & 'C' 4-Bolt Flg.			SAE 4-Bolt Conn. Port		Connector Hole Diameter			
				For Both Sections		Front		Rear	
	A	B	C	Inlet	Outlet	Inlet	Outlet	Inlet	Outlet
TP25550 - 550 A & C	128.5 (5.06)	376.1 (14.81)	18.56 (471.4)	2-1/2"	1-1/2"	63.5 (2.50)	42.6 (1.68)	63.5 (2.50)	38.1 (1.50)
TP25660 - 550 A & C	137.9 (5.43)	482.0 (15.23)	18.98 (482.0)	2-1/2"	1-1/2"	63.5 (2.50)	42.6 (1.68)	63.5 (2.50)	38.1 (1.50)
TP25660 - 660 A & C	137.9 (5.43)	488.4 (15.48)	19.23 (488.4)	2-1/2"	1-1/2"	63.5 (2.50)	42.6 (1.68)	63.5 (2.50)	38.1 (1.50)
TP25770 - 550 A & C	147.5 (5.81)	491.3 (15.60)	19.35 (491.3)	2-1/2"	1-1/2"	63.5 (2.50)	42.6 (1.68)	63.5 (2.50)	38.1 (1.50)
TP25770 - 660 A & C	147.5 (5.81)	497.8 (15.85)	19.60 (497.8)	2-1/2"	1-1/2"	63.5 (2.50)	42.6 (1.68)	63.5 (2.50)	38.1 (1.50)
TP25770 - 770 A & C	147.5 (5.81)	504.1 (16.10)	19.85 (504.1)	2-1/2"	1-1/2"	63.5 (2.50)	42.6 (1.68)	63.5 (2.50)	38.1 (1.50)

MOUNTING DIMENSIONS											
PUMP SIZE	For 'C' 2-Bolt & 'C' 4-Bolt Flg.			SAE 4-Bolt Conn. Port				Connector Hole Diameter			
				Front Sect.		Rear Sect.		Front		Rear	
	A	B	C	Inlet	Outlet	Inlet	Outlet	Inlet	Outlet	Inlet	Outlet
TP25950 - 550 A & C	165.6 (6.52)	413.2 (16.22)	508.5 (20.02)	3"	2"	2-1/2"	1-1/2"	63.5 (2.50)	42.6 (1.68)	63.5 (2.50)	38.1 (1.50)
TP25950 - 660 A & C	165.6 (6.52)	419.6 (16.52)	514.8 (20.27)	3"	2"	2-1/2"	1-1/2"	63.5 (2.50)	42.6 (1.68)	63.5 (2.50)	38.1 (1.50)
TP25950 - 770 A & C	165.6 (6.52)	425.9 (16.77)	521.2 (20.52)	3"	2"	2-1/2"	1-1/2"	63.5 (2.50)	42.6 (1.68)	63.5 (2.50)	38.1 (1.50)
TP25950 - 950 A & C	165.6 (6.52)	442.4 (17.42)	537.4 (21.16)	3"	2"	3"	2"	63.5 (2.50)	42.6 (1.68)	63.5 (2.50)	50.8 (2.00)

SAE 4-Bolt Connector Ports							
Size	D	E	F	G	H	J	
						'A' Rotation	'C' Rotation
1-1/2"	19.7 (.70)	35.7 (1.406)	34.7 (1.37)	69.8 (2.750)	1/2-13NC	38.1 (1.50)	25.4 (1.00)
2-1/2"	25.4 (1.00)	50.8 (2.000)	44.4 (1.75)	88.9 (3.500)	1/2-13NC	38.1 (1.50)	25.4 (1.00)
3"	30.9 (1.22)	61.9 (2.438)	59.6 (2.35)	119.3 (4.700)	5/8-11NC	38.1 (1.50)	25.4 (1.00)

SAE 4-Bolt NPT Connectors are available. See Accessory Section

Inch equivalents for millimeter dimensions are shown in (**).

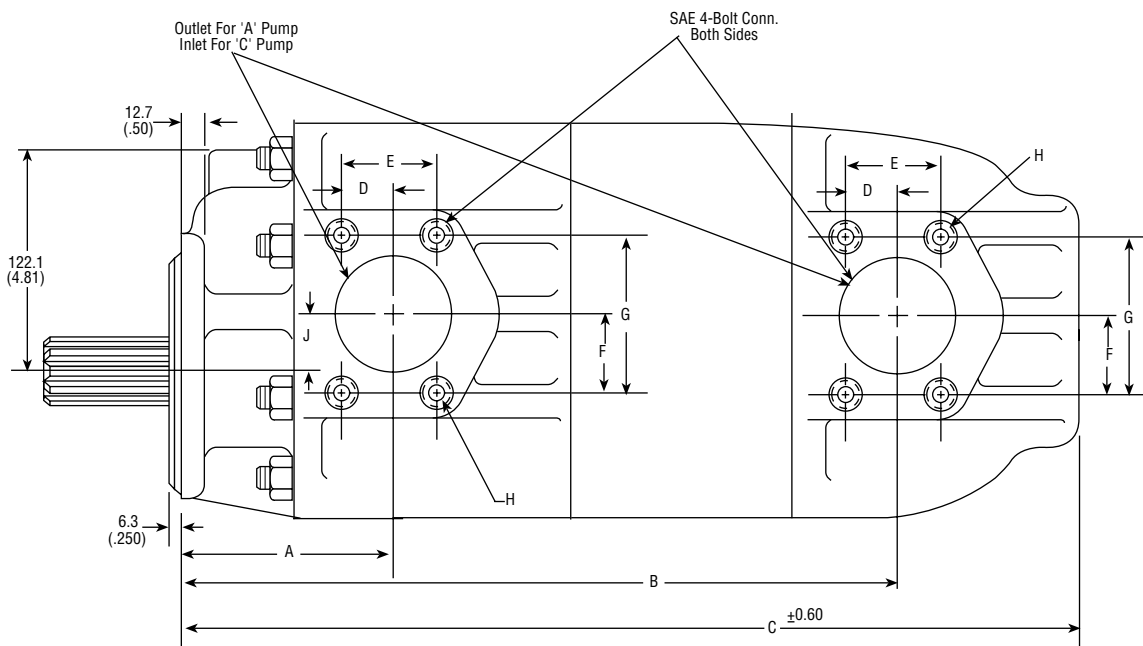

**Specifications
for PB25 Series**

Description Gear Pumps
Flow Range To 167 GPM (632.1 LTR.)
Displacements To 15.50 C.I.R. (254.40 CC's/REV.)
Maximum Pressure to 3000 PSI (207 BAR)
Maximum Speed to 2500 RPM
Rotation A or C
Bearings Journal
Construction Aluminum

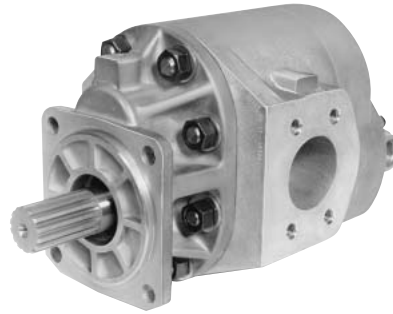

Performance Data

Pump Model	Section Size	Displacement/Revolution (Theoretical)					Maximum Pressure		Maximum Speed
		US Gallons	Cubic Inches	Liters	Cubic Centimeters	Imperial Gallons	PSI	BAR	
25	350	.0306	7.07	.1158	115.857	.025	3000	207	2500
25	400	.0350	8.08	.1324	132.408	.029	3000	207	2500
25	450	.0394	9.10	.1491	149.123	.033	3000	207	2500
25	500	.0435	10.05	.1647	164.690	.036	2500	172	2500
25	550	.0479	11.06	.1812	181.241	.040	2500	172	2500
25	660	.0581	13.42	.2200	219.915	.048	2500*	172*	2500
25	770	.0671	15.50	.2540	254.400	.056	2500*	172*	2500

Available with Viton® Seals. All data based on SAE 10W oil at 150 °F.
*Consult factory for application approval.



CAUTION: "Inlet vacuum" should not exceed 5" Hg at normal operating speed and temperature. Operation of pumps in excess of 5" Hg requires factory approval.

Dimensional Data

Mounting Dimensions								
Pump Size	For 'C' 2-Bolt & 'C' 4-Bolt Flg.		SAE 4-Bolt Conn. Port		L		Shipping Weights	
	A	B	Suction	Disc.	A Rotation	C Rotation	lbs.	kgs.
PB25350	123.9 (4.88)	266.4 (10.49)	2-1/2"	1-1/2"	38.1 (1.50)	25.4 (1.00)	52	19.40
PB25400	128.9 (5.06)	271.0 (10.67)	2-1/2"	1-1/2"	38.1 (1.50)	25.4 (1.00)	54	20.16
PB25450	128.9 (5.06)	271.0 (10.67)	2-1/2"	1-1/2"	38.1 (1.50)	25.4 (1.00)	56	20.90
PB25500	123.9 (4.88)	266.4 (10.49)	2-1/2"	1-1/2"	38.1 (1.50)	25.4 (1.00)	58	21.65
PB25550	128.9 (5.06)	271.0 (10.67)	2-1/2"	1-1/2"	38.1 (1.50)	25.4 (1.00)	60	22.39
PB25660	138.1 (5.44)	281.6 (11.09)	2-1/2"	1-1/2"	38.1 (1.50)	25.4 (1.00)	62	23.14
PB25770	147.5 (5.81)	291.0 (11.46)	2-1/2"	1-1/2"	38.1 (1.50)	25.4 (1.00)	64	23.88

SAE 4-Bolt Connector Ports					
Size	F	G	H	J	K
1-1/2"	17.7 (.70)	35.7 (1.406)	34.7 (1.37)	69.8 (2.750)	1/2-13NC
2-1/2"	25.4 (1.00)	50.8 (2.000)	44.4 (1.75)	88.9 (3.500)	1/2-13NC

SAE 4-Bolt connectors are available. See Accessory Section.

Inch equivalents for millimeter dimensions are shown in (**).

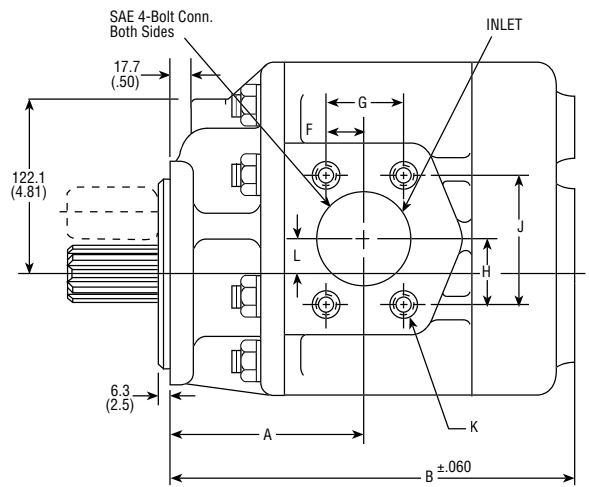
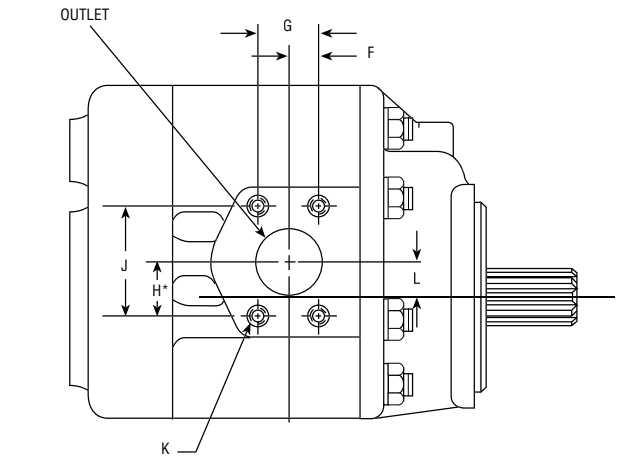
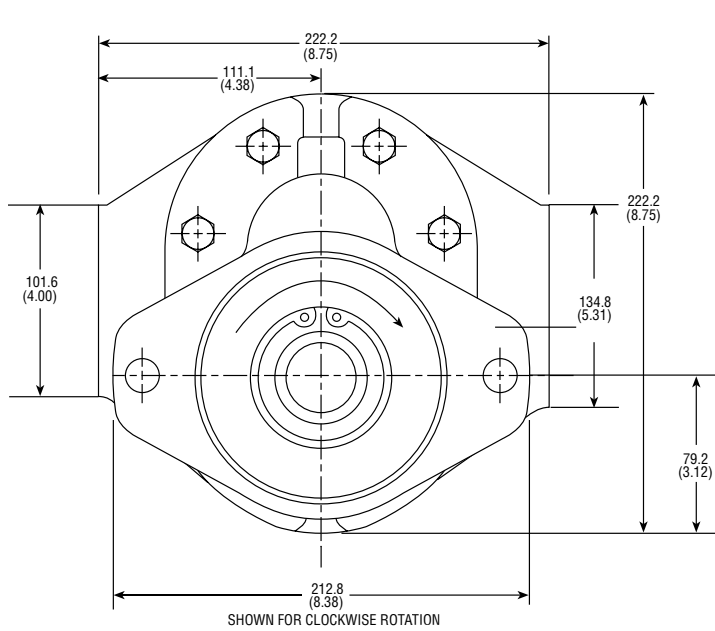

Shafts Available for 25 Series

Inch equivalents for millimeter dimensions are shown in (**).

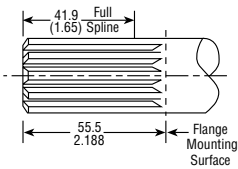
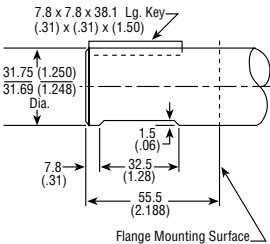
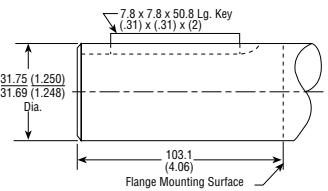
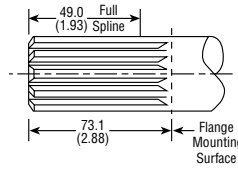
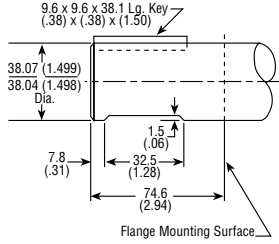
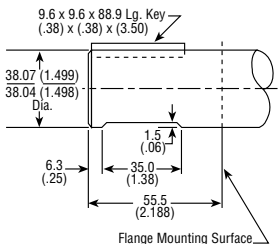
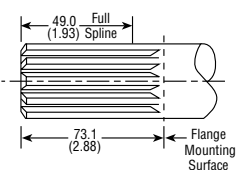
<p>1 SAE 'C' 1-1/4" 14 Tooth Spline Flat Root Side Fit Torque limit 655 Lbs. Ft. (888.0 Nm) Available for all single section sizes and PB25 sizes 350 to 660 only</p>  <p>Spline Data Diametral Pitch 12/24 Pressure Angle 30° No. Of Teeth 14</p>	<p>2 SAE 'C' 1-1/4" Straight Shaft Torque limit 655 Lbs. Ft. (888.0 Nm) Available for all single section sizes only</p> 	<p>5 1-1/4" Straight Shaft Torque limit 655 Lbs. Ft. (888.0 Nm) Available for all single section sizes only</p> 
<p>6 1-1/2" 17 Tooth Spline Flat Root Side Fit Torque limit 1180 Lbs. Ft. (1600.0 Nm) Available for TP25500, TP25550, TP25660 & TP25770 only</p>  <p>Spline Data Diametral Pitch 12/24 Pressure Angle 30° No. Of Teeth 17</p>	<p>7 1-1/2" Dia. Straight Shaft Torque limit 1180 Lbs. Ft. (1600.0 Nm) - Not available for all single section pumps Available for: TP25500, TP25550, TP25660, TP25770 & TP25950 PB25500, PB25550, PB25660 & PB25770</p> 	
<p>8 1-1/2" Dia. Straight Shaft Torque limit 1180 Lbs. Ft. (1600.0 Nm) Available for Tandem Pumps only, in sizes TP25500, TP25550, TP25660 & TP25770 only</p> 	<p>9 1-1/2" 14 Tooth Spline Flat Root Side Fit Torque limit 1180 Lbs. Ft. (1600.0 Nm)</p>  <p>Spline Data Diametral Pitch 10/20 Pressure Angle 30° No. Of Teeth 14</p>	

Mounting Flanges Available for 25 Series

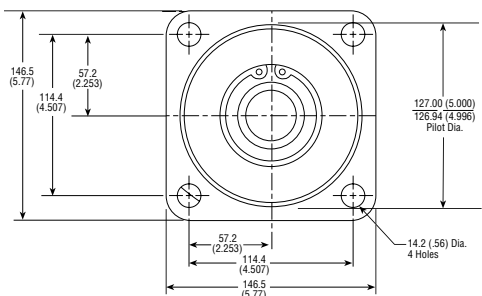
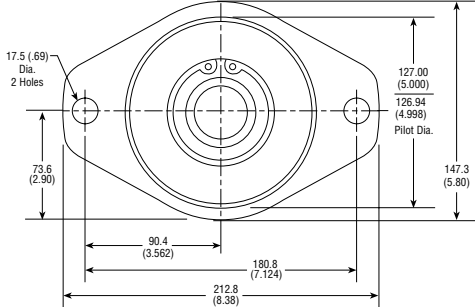
<p>E SAE 'C' 4-Bolt</p> 	<p>F SAE 'C' 2-Bolt</p> 
---	--

Couplings Available for 25 Series Piggy Back Style

<p>50 1/2" Straight</p> <p>Kit No. 13974</p>	<p>75 3/4" Straight</p> <p>Kit No. 13975</p>
<p>88 7/8" 13 Tooth Spline</p> <p>Kit No. 13976</p>	<p>125 1-1/4" 14 Tooth Spline</p> <p>Kit No. 13978</p>

Transition Plates Available for 25 Series Piggy Back Style

<p>A SAE 'A' 2-Bolt Shown with No. 50 Coupling</p> <p>Transition Plate for 2-Bolt 'A' Flange Shown With No. 50 Coupling</p> <p>Partial Section A-A</p>	<p>B SAE 'B' 2 & 4-Bolt Shown with No. 125 Coupling</p> <p>Transition Plate for 2-Bolt and 4-Bolt 'B' Flange Shown With No. 125 Coupling</p> <p>Partial Section M-M</p>
---	--

Inch equivalents for millimeter dimensions are shown in (**).

General Information for HP Series

■ Available in various configurations:

- HP7 – Single Section
- THP7 – Tandem, 2-Place

- HP8 – Single Section
- THP8 – Tandem, 2-Place

■ Construction:

- Aluminum body and flange for excellent power to weight ratio
- Journal bearings for long life and good over-hung load capability
- Buna-N Seals are standards for petroleum and glycol based fluids. “VitonE®” seals are optional.
- Pressure balanced plates for greater efficiency
- Aluminum construction for the best power to weight ratio
- Journal bearings for long life and good over-hung load capability
- Buna-N Seals are standard for petroleum and glycol based fluids. “Viton®E” seals are optional.
- Pressure-balanced plates for greater efficiency

■ HP7 - THP7 Features:

- Displacements to 10.74 C.I.R.
- Pressures to 4000 PSI

■ HP8 - THP8 Features:

- Displacements to 116.38 C.I.R.
- Pressures to 4000 PSI



How to Order HP Series:

Select the desired symbol (in the correct position) to construct a model code.

Assembly Example:

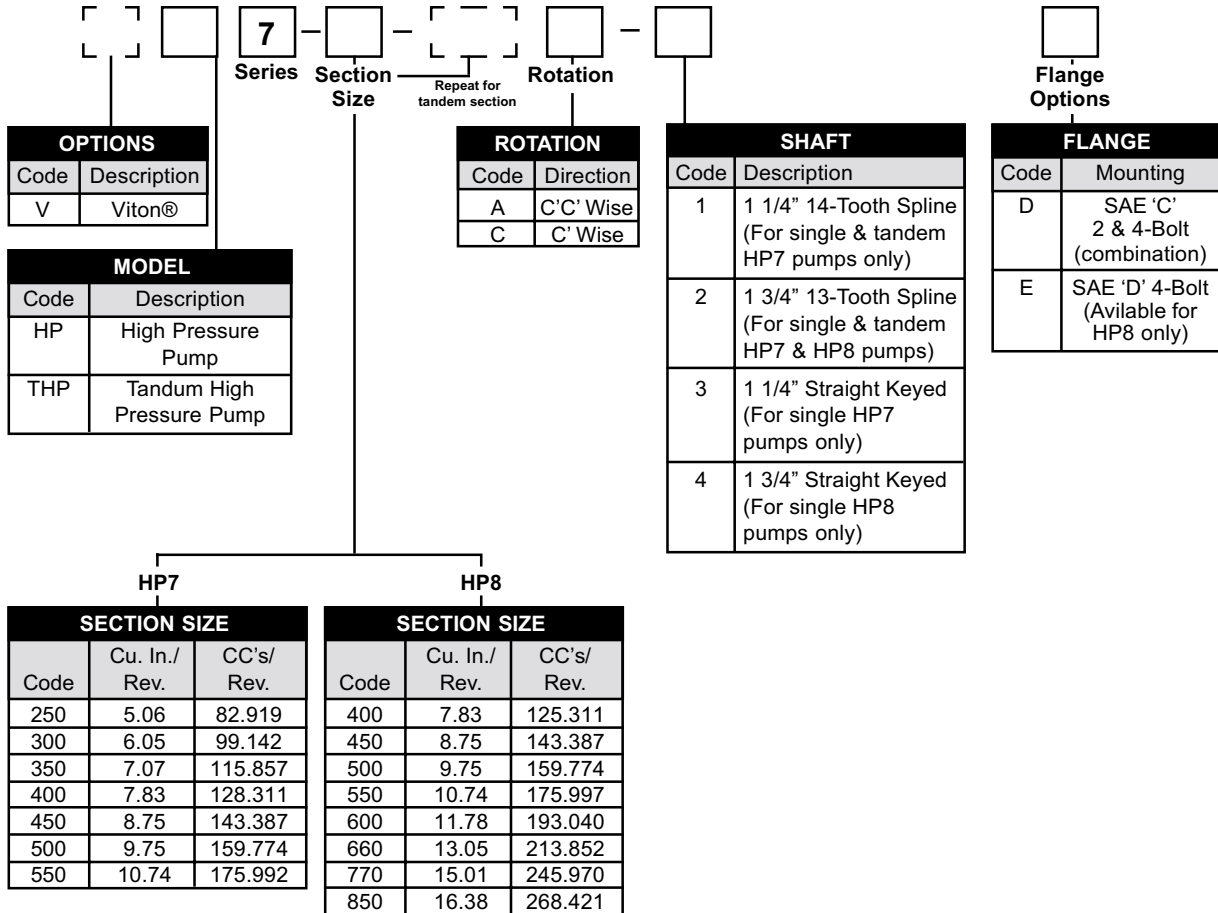

**Specifications
 for HP7-THP7 Series**

Description..... Gear Pumps
 Flow Range To 116 GPM Per Section (440.01 LTR.)
 Displacements To 10.74 C.I.R. Per Section (176.00 CC's/REV.)
 Maximum Pressure to 4000 PSI (276 BAR)
 Maximum Speed to 2500 RPM
 Rotation A or C
 Bearings..... Journal
 Construction Aluminum

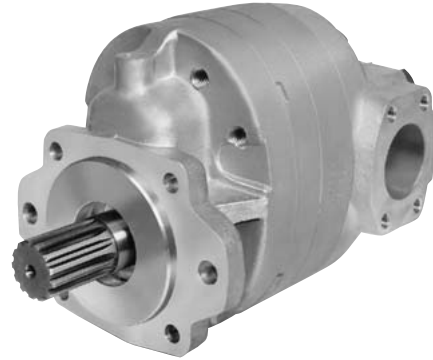

Performance Data Per Section

Pump Model	Section Size	Displacement/Revolution (Theoretical)					Maximum Pressure		Maximum Speed
		US Gallons	Cubic Inches	Liters	Cubic Centimeters	Imperial Gallons	PSI	BAR	RPM
HP7	250	.0219	5.06	.0829	82.919	.0182	4000	276	2500
HP7	300	.0262	6.05	.0991	99.142	.0218	4000	276	2500
HP7	350	.0306	7.07	.1159	115.857	.0255	4000	276	2500
HP7	400	.0339	7.83	.1283	128.311	.0282	4000	276	2500
HP7	450	.0379	8.75	.1434	143.387	.0316	3700	255	2500
HP7	500	.0422	9.75	.1598	159.774	.0351	3300	228	2500
HP7	550	.0465	10.74	.1760	175.997	.0387	3000	207	2500

All data based on SAE 10W oil at 150°F. Available with Viton® seals



CAUTION: "Inlet vacuum" should not exceed 5" Hg at normal operating speed and temperature. Operation of pumps in excess of 5" Hg requires factory approval.

Dimensional Data

Mounting Dimensions				
Size	A	B	C	D
HP7-250 A & C	184.4 (7.26)	197.1 (7.76)	249.4 (9.82)	197.1 (7.76)
HP7-300 A & C	190.2 (7.49)	202.9 (7.99)	255.2 (10.05)	202.9 (7.99)
HP7-350 A & C	195.8 (7.71)	208.5 (8.21)	260.8 (10.27)	208.5 (8.21)
HP7-400 A & C	200.4 (7.89)	213.1 (8.39)	265.4 (10.45)	213.1 (8.39)
HP7-450 A & C	205.7 (8.10)	218.4 (8.60)	270.7 (10.66)	218.4 (8.60)
HP7-500 A & C	211.3 (8.32)	224.0 (8.82)	276.3 (10.88)	224.0 (8.82)
HP7-550 A & C	216.9 (8.54)	229.6 (9.04)	281.9 (11.10)	229.6 (9.04)

Dimensional Data

Inch equivalents for millimeter dimensions are shown in (**).

SAE 4-Bolt connectors are available. See Accessory Section only

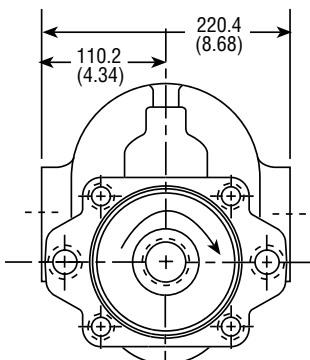
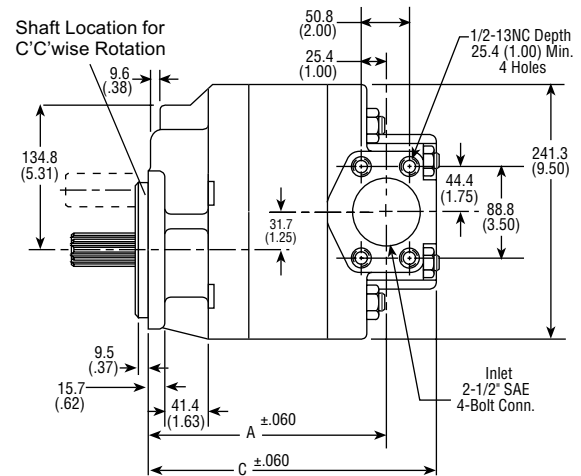
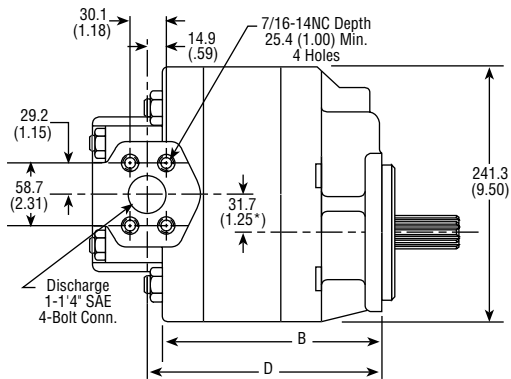
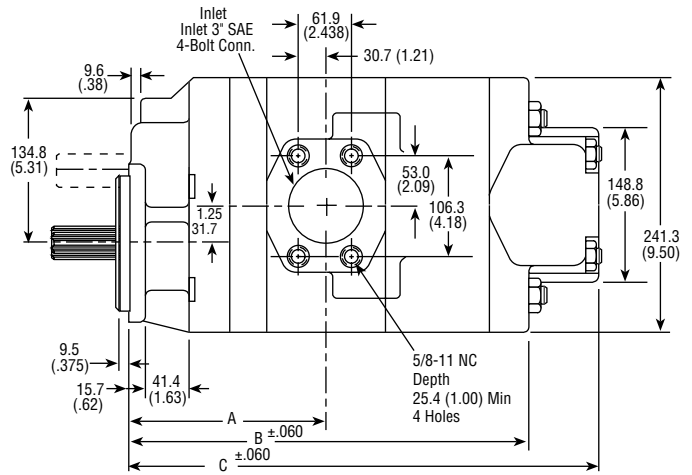
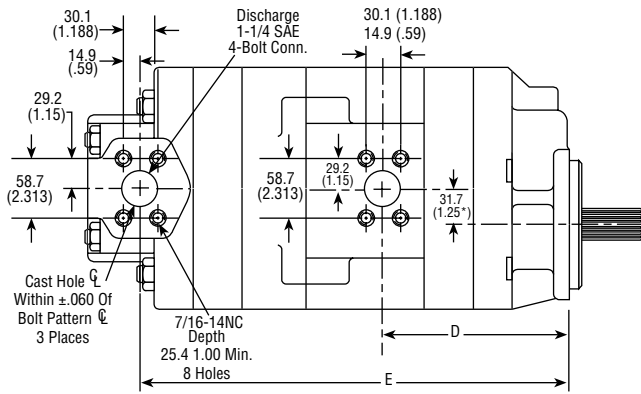

SHOWN FOR CLOCKWISE ROTATION

Dimensional Data

SAE 4-Bolt Connector Ports					
Combinations Avail.	A	B	C	D	E
THP7-250 - 250 A & C	206.7 (8.14)	432.3 (17.02)	497.3 (19.58)	187.4 (7.38)	445.0 (17.52)
THP7-300 - 250 A & C	212.3 (8.36)	437.8 (17.24)	502.9 (19.80)	193.0 (7.60)	450.5 (17.74)
THP7-300 - 300 A & C	212.3 (8.36)	443.4 (17.46)	508.5 (20.02)	193.0 (7.60)	456.1 (17.96)
THP7-350 - 250 A & C	212.3 (8.58)	443.4 (17.46)	508.5 (20.02)	198.6 (7.82)	456.1 (17.96)
THP7-350 - 300 A & C	212.3 (8.58)	449.0 (17.68)	514.0 (20.24)	198.6 (7.82)	461.7 (18.18)
THP7-350 - 350 A & C	121.3 (8.58)	454.6 (17.90)	519.6 (20.46)	198.6 (7.82)	467.3 (18.40)
THP7-400 - 250 A & C	222.5 (8.76)	448.0 (17.64)	513.0 (20.20)	203.2 (8.00)	460.7 (18.14)
THP7-400 - 300 A & C	222.5 (8.76)	453.6 (17.86)	518.6 (20.42)	203.2 (8.00)	466.3 (18.36)
THP7-400 - 350 A & C	222.5 (8.76)	459.2 (18.08)	524.2 (20.64)	203.2 (8.00)	471.9 (18.58)
THP7-400 - 400 A & C	222.5 (8.76)	463.8 (18.26)	528.8 (20.82)	203.2 (8.00)	476.5 (18.76)
THP7-450 - 250 A & C	227.8 (8.97)	453.6 (17.86)	518.6 (20.42)	208.5 (8.21)	466.3 (18.36)
THP7-450 - 300 A & C	227.8 (8.97)	454.2 (18.08)	524.2 (20.64)	208.5 (8.21)	471.9 (18.58)
THP7-450 - 350 A & C	227.8 (8.97)	464.8 (18.30)	529.8 (20.86)	208.5 (8.21)	477.5 (18.80)
THP7-450 - 400 A & C	227.8 (8.97)	469.1 (18.47)	534.1 (21.03)	208.5 (8.21)	481.8 (18.97)
THP7-450 - 450 A & C	227.8 (8.97)	474.4 (18.68)	539.4 (21.24)	208.5 (8.21)	487.1 (19.18)
THP7-500 - 250 A & C	233.6 (9.20)	459.2 (18.08)	524.2 (20.64)	214.3 (8.44)	471.9 (18.58)
THP7-500 - 300 A & C	233.6 (9.20)	464.8 (18.30)	529.8 (20.86)	214.3 (8.44)	477.5 (18.80)
THP7-500 - 350 A & C	233.6 (9.20)	470.4 (18.52)	535.4 (21.08)	214.3 (8.44)	483.1 (19.02)
THP7-500 - 400 A & C	233.6 (9.20)	474.9 (18.70)	540.0 (21.26)	214.3 (8.44)	487.6 (19.20)
THP7-500 - 450 A & C	233.6 (9.20)	480.5 (18.92)	545.5 (21.48)	214.3 (8.44)	493.2 (19.42)
THP7-500 - 500 A & C	233.6 (9.20)	486.1 (19.14)	551.1 (21.70)	214.3 (8.44)	498.8 (19.64)
THP7-550 - 250 A & C	239.2 (9.42)	464.8 (18.30)	529.8 (20.86)	219.9 (8.66)	477.5 (18.80)
THP7-550 - 300 A & C	239.2 (9.42)	470.4 (18.52)	535.4 (21.08)	219.9 (8.66)	483.1 (19.02)
THP7-550 - 350 A & C	239.2 (9.42)	475.9 (18.74)	541.0 (21.30)	219.9 (8.66)	488.6 (19.24)
THP7-550 - 400 A & C	239.2 (9.42)	480.5 (18.92)	545.5 (21.48)	219.9 (8.66)	493.2 (19.42)
THP7-550 - 450 A & C	239.2 (9.42)	486.1 (19.14)	551.1 (21.70)	219.9 (8.66)	498.8 (19.64)
THP7-550 - 500 A & C	239.2 (9.42)	491.7 (19.36)	556.2 (21.92)	219.9 (8.66)	504.4 (19.86)
THP7-550 - 550 A & C	239.2 (9.42)	497.3 (19.58)	562.3 (22.14)	219.9 (8.66)	510.0 (20.08)

**Specifications
for HP8-THP8 Series**

Description Gear Pumps
Flow Range To 177 GPM Per Section (670.0 LTR.)
Displacements To 16.38 C.I.R. Per Section (268.42 CC's/REV.)
Maximum Pressure to 4000 PSI (276 BAR)
Maximum Speed to 2500 RPM
Rotation A or C
Bearings Journal
Construction Aluminum



Performance Data Per Section

Pump Model	Section Size	Displacement/Revolution (Theoretical)					Maximum Pressure		Maximum Speed* RPM
		US Gallons	Cubic Inches	Liters	Cubic Centimeters	Imperial Gallons	PSI	BAR	
HP8	400	.0339	7.83	.1283	128.311	.028	4000	276	2500
HP8	450	.0379	8.75	.1434	143.387	.032	4000	276	2500
HP8	500	.0422	9.75	.1598	159.774	.035	4000	276	2500
HP8	550	.0465	10.74	.1760	175.997	.039	4000	276	2500
HP8	600	.0510	11.78	.1930	193.040	.042	4000	276	2500
HP8	660	.0565	13.05	.2138	213.852	.047	3600	248	2500
HP8	770	.0650	15.01	.2460	245.970	.054	3300	228	2500
HP8	850	.0709	16.38	.2683	268.421	.059	3000	207	2500

All data based on SAE 10W oil at 150°F. Available with Viton® seals.
Note: Pressurized suction required: Speeds to 2000 RPM require 0 PSI minimum.
*Speeds above 2000 RPM require the suction to be pressurized to 5 PSI minimum.

CAUTION: "Inlet vacuum" should not exceed 5" Hg at normal operating speed and temperature. Operation of pumps in excess of 5" Hg requires factory approval.

Dimensional Data

Inch equivalents for millimeter dimensions are shown in (**).

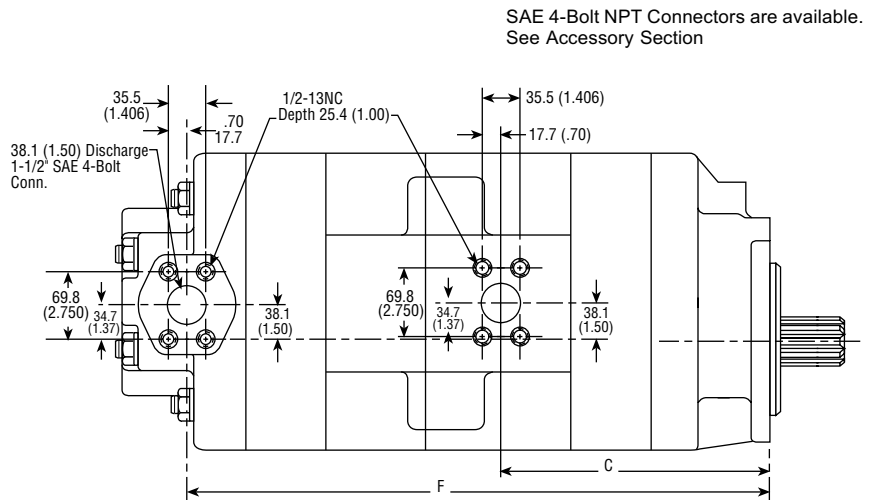
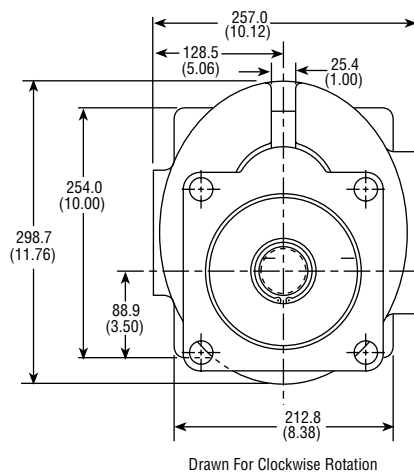

SAE 4-Bolt NPT Connectors are available. See Accessory Section

Dimensional Data

SAE 4-Bolt Connector Ports				
Combinations Avail.	C	D	E	F
THP8-400 - 400 A & C	250.6 (9.87)	532.8 (20.98)	606.0 (23.86)	544.0 (21.42)
THP8-450 - 400 A & C	254.7 (10.03)	536.9 (21.14)	610.1 (24.02)	548.1 (21.58)
THP8-450 - 450 A & C	254.7 (10.03)	541.0 (21.30)	614.1 (24.18)	552.1 (21.74)
THP8-500 - 400 A & C	259.9 (10.20)	541.2 (21.31)	614.4 (24.19)	552.4 (21.75)
THP8-500 - 450 A & C	259.9 (10.20)	545.3 (21.47)	618.4 (24.35)	556.5 (21.91)
THP8-500 - 500 A & C	259.9 (10.20)	549.6 (21.64)	622.8 (24.52)	560.8 (22.08)
THP8-550 - 400 A & C	263.3 (10.37)	545.5 (21.48)	618.7 (24.36)	556.7 (21.92)
THP8-550 - 450 A & C	263.3 (10.37)	549.6 (21.64)	622.8 (24.52)	560.8 (22.08)
THP8-550 - 500 A & C	263.3 (10.37)	553.9 (21.81)	627.1 (24.69)	565.1 (22.25)
THP8-550 - 550 A & C	263.3 (10.37)	558.2 (21.98)	631.4 (24.86)	569.4 (22.42)
THP8-600 - 400 A & C	267.9 (10.55)	550.1 (21.66)	623.3 (24.54)	561.3 (22.10)
THP8-600 - 450 A & C	267.9 (10.55)	554.2 (21.82)	627.3 (24.70)	565.4 (22.26)
THP8-600 - 500 A & C	267.9 (10.55)	558.5 (21.99)	631.6 (24.87)	569.7 (22.43)
THP8-600 - 550 A & C	267.9 (10.55)	562.8 (22.16)	636.0 (25.04)	574.0 (22.60)
THP8-600 - 600 A & C	267.9 (10.55)	567.4 (22.34)	649.5 (25.22)	578.6 (22.78)
THP8-660 - 400 A & C	273.5 (10.77)	555.7 (21.88)	628.9 (24.76)	566.9 (22.32)
THP8-660 - 450 A & C	273.5 (10.77)	559.8 (22.04)	632.9 (24.92)	570.9 (22.48)
THP8-660 - 500 A & C	273.5 (10.77)	564.1 (22.21)	637.2 (25.09)	575.3 (22.65)
THP8-660 - 550 A & C	273.5 (10.77)	568.4 (22.38)	641.6 (25.26)	579.6 (22.82)
THP8-660 - 600 A & C	273.5 (10.77)	573.0 (22.56)	646.1 (25.44)	584.2 (23.00)
THP8-660 - 660 A & C	273.5 (10.77)	578.6 (22.78)	651.7 (25.66)	589.7 (23.22)
THP8-770 - 400 A & C	282.4 (11.12)	564.6 (22.23)	637.7 (25.11)	575.8 (22.67)
THP8-770 - 450 A & C	282.4 (11.12)	568.7 (22.39)	641.8 (25.27)	579.8 (22.83)
THP8-770 - 500 A & C	282.4 (11.12)	573.0 (22.56)	646.1 (25.44)	584.2 (23.00)
THP8-770 - 550 A & C	282.4 (11.12)	577.3 (22.73)	650.4 (25.61)	588.5 (23.17)
THP8-770 - 600 A & C	282.4 (11.12)	581.9 (22.91)	655.0 (25.79)	593.0 (23.35)
THP8-770 - 660 A & C	282.4 (11.12)	587.5 (23.13)	660.6 (26.01)	598.6 (23.57)
THP8-770 - 770 A & C	282.4 (11.12)	596.3 (23.48)	669.5 (26.36)	607.5 (23.92)
THP8-850 - 400 A & C	288.5 (11.36)	570.7 (22.47)	643.8 (25.35)	581.9 (22.91)
THP8-850 - 450 A & C	288.5 (11.36)	574.8 (22.63)	647.9 (25.51)	585.9 (23.07)
THP8-850 - 500 A & C	288.5 (11.36)	579.1 (22.80)	652.2 (25.68)	590.2 (23.24)
THP8-850 - 550 A & C	288.5 (11.36)	583.4 (22.97)	656.5 (25.85)	594.6 (23.41)
THP8-850 - 600 A & C	288.5 (11.36)	588.0 (23.15)	661.1 (26.03)	599.1 (23.59)
THP8-850 - 660 A & C	288.5 (11.36)	593.5 (23.37)	666.7 (26.25)	604.7 (23.81)
THP8-850 - 770 A & C	288.5 (11.36)	602.4 (23.72)	675.6 (26.60)	613.6 (24.16)
THP8-850 - 850 A & C	288.5 (11.36)	608.5 (23.96)	681.7 (26.84)	619.7 (24.40)

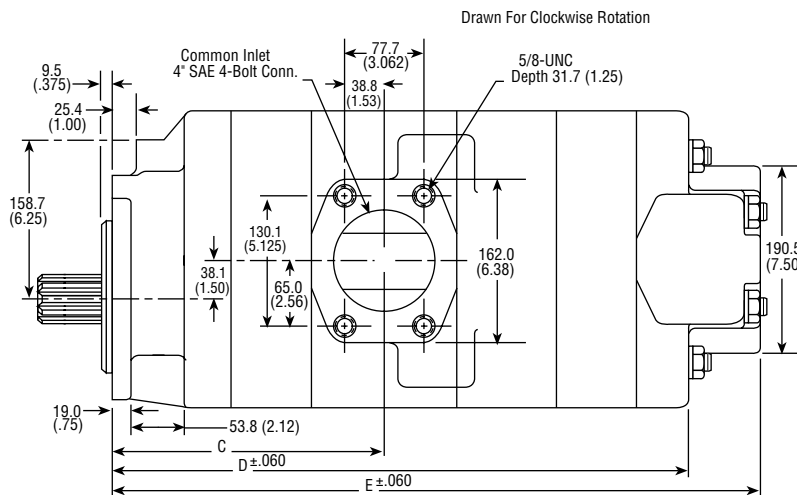

Inch equivalents for millimeter dimensions are shown in (**).

SAE 4-Bolt NPT Connectors are available. See Accessory Section

Dimensional Data

SAE 4-Bolt Connector Ports		
Combinations Avail.	A	B
HP8-400	239.52 (9.43)	301.5 (11.87)
HP8-450	243.59 (9.59)	305.56 (12.03)
HP8-500	247.9 (9.76)	309.88 (12.20)
HP8-550	252.22 (9.93)	314.20 (12.37)
HP8-600	256.79 (10.11)	318.77 (12.55)
HP8-660	262.38 (10.33)	324.36 (12.77)
HP8-770	271.27 (10.68)	333.25 (13.12)
HP8-850	277.37 (10.92)	339.34 (13.36)

Inch equivalents for millimeter dimensions are shown in (**).

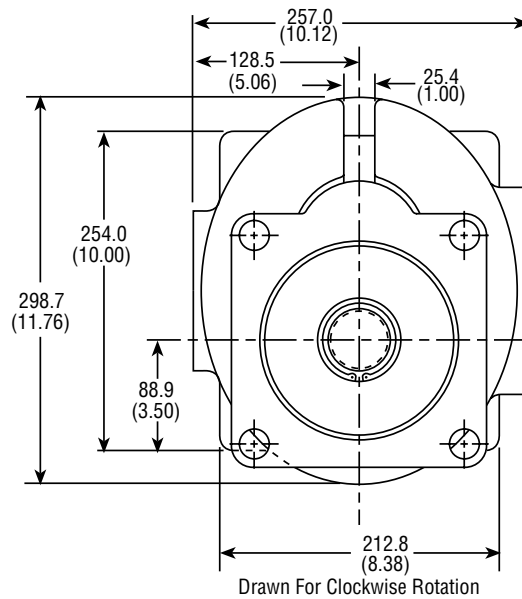
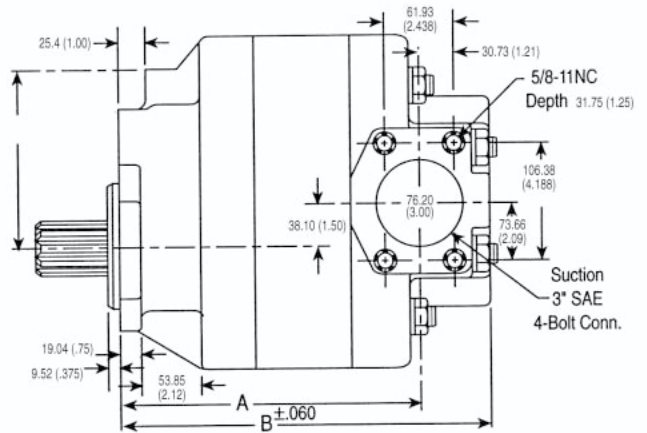
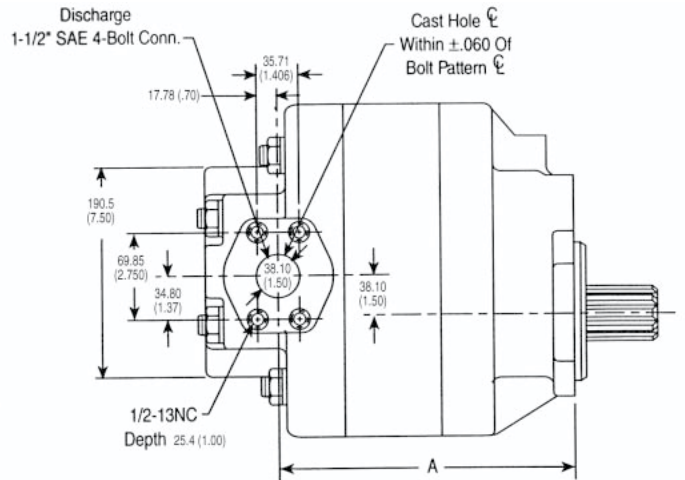

Shafts Available for HP Series

Inch equivalents for millimeter dimensions are shown in (**).

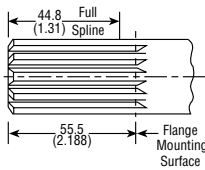
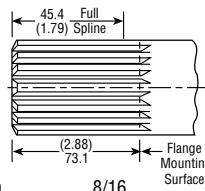
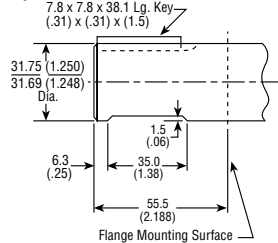
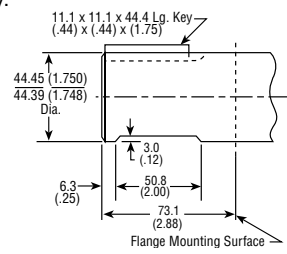
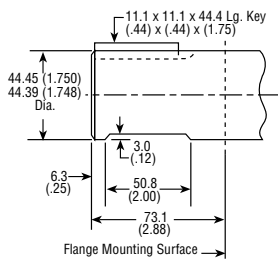
<p>1 1-1/4" 14 Tooth Spline Flat Root Side Fit Torque Limit 655 Lb. Ft. (888.0 Nm) Available for all Single section HP7 and Tandem THP7 sizes only.</p>  <p>Spline Data Diametral Pitch 12/24 Pressure Angle 30° No. Of Teeth 14</p>	<p>2 1-3/4" 13 Tooth Spline Flat Root Side Fit Torque Limit 1800 Lb. Ft. (2440.4 Nm) Available for all Single section HP7, HP8 and Tandem THP7 and THP8 sizes</p>  <p>Spline Data Diametral Pitch 8/16 Pressure Angle 30° No. Of Teeth 13</p>	<p>3 1-1/4" Straight Shaft for SINGLE Units Only Flat Root Side Fit Torque Limit 655 Lb. Ft. (880.0 Nm) Available for all Single section HP7 sizes only.</p> 
<p>3 1-3/4" Straight Shaft for TANDEM Units Only Flat Root Side Fit Torque Limit 1800 Lb. Ft. (2440.4 Nm) Available for all Tandem THP7 sizes only.</p> 	<p>4 1-3/4" Straight Shaft Torque Limit 1800 Lbs. Ft. (2440.4 Nm) Available for all Single section HP8 sizes only.</p> 	

Mounting Flanges Available for HP Series

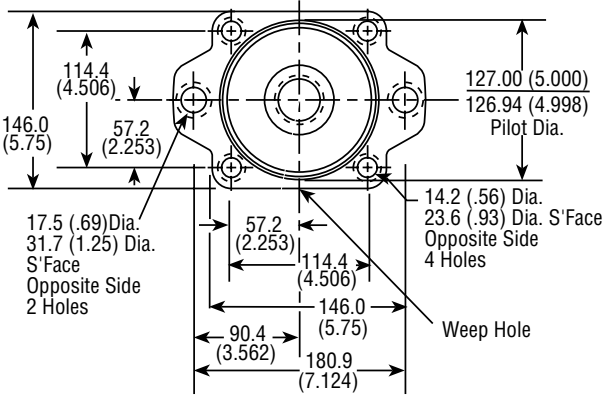
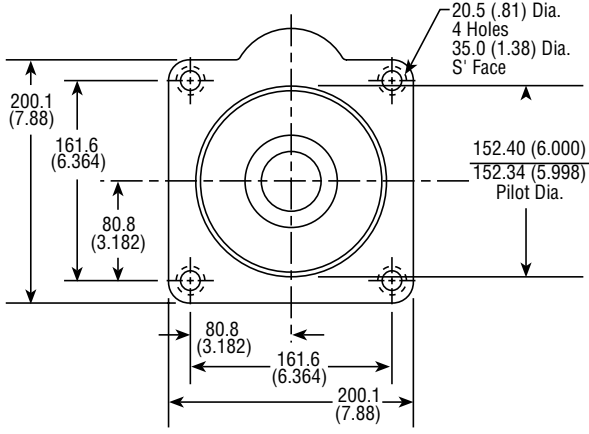
<p>D SAE 'C' 2- & 4 Bolt - HP7 & HP8</p> 	<p>E SAE 'D' 4-Bolt - HP8 Only</p> 
--	---

General Information for Gear Motor Series

■ Available is the following:

UM 16 – Uni- (single) directional motor not designed for series operation

M20 – Bi-directional, good for series operation

TM20 – Bi-directional, good for series operation

SPM20 – Bi-directional, good for series operation

M25 – Bi-directional, good for series operation

TM25 – Bi-directional, good for series operation

SPM25 – Bi-directional, good for series operation

■ Journal bearings for long life and good over-hung load capability

■ Buna-N-Seals are standard for petroleum and glycol based fluids “Viton®E” seals are optional.

■ Pressure balanced plates for greater efficiency.



How to Order Gear Motor Series:

Select the desired symbol (in the correct position) to construct a model code.

Assembly Example:

The diagram illustrates the construction of a model code for a gear motor. It shows a sequence of boxes representing different components: Options, Series (with '16' selected), Section Size, Repeat tandem section, Rotation, Flange Options, and another Section Size. Below these are detailed tables for each component.

OPTIONS	
Code	Description
V	Viton®

MODEL	
Code	Description
UM	Uni-directional Motor
M	Motor
TM	Tandem Motor
SPM	Series/Parrallel Motor

SERIES	
Code	Description
16	16
20	20
25	25

ROTATION	
Code	Direction
A	C' C' Wise
C	C' Wise

Note: M20, M25 TM25 and SPM25 leave blank for Bi-Rotational

UM16 SECTION SIZE		
Code	Cu. In./ Rev.	CC's/ Rev.
45	.878	14.39
65	1.270	20.81
85	1.663	27.25
100	1.964	32.18
115	2.241	36.72
150	2.934	48.08
180	3.511	57.54
200	3.904	63.98

M20 / SPM20 SECTION SIZE		
Code	Cu. In./ Rev.	CC's/ Rev.
150	3.02	49.85
200	4.04	66.20
250	5.06	82.92
300	6.05	99.14
350	7.07	115.86
400	8.08	132.41
450	9.10	149.12

M25 / TM25 / SPM25 SECTION SIZE		
Code	Cu. In./ Rev.	CC's/ Rev.
550	11.06	181.94
660	13.42	219.91
770	15.50	254.00

UM16 SHAFT	
Code	Description
2	7/8" 13-Tooth Spline
5	7/8" Straight Keyed
6	3/4" Straight Keyed

M20 / SPM20 SHAFT	
Code	Description
1	1 1/4" 14-Tooth Spline
2	1" Straight Keyed
3	1 1/4" Straight Keyed
4	7/8" 13-Tooth Spline
5	1 1/4" Straight Keyed Long

M25 SHAFT	
Code	Description
1	1 1/4" 14-Tooth Spline
2	1 1/4" Straight Keyed
5	1 1/4" Straight Keyed Long

TM25 & SPM25 SHAFT	
Code	Description
1	1 1/4" 14-Tooth Spline
6	1 1/2" 17-Tooth Spline
7	1 1/2" Straight Keyed
8	1 1/2" Straight Keyed Long
9	1 1/2" 14-Tooth Spline

COVER PLATE (UM16 ONLY)			
Code	Port	Inlet	Outlet
1	Side	#16 SAE (1-5/16"-12UN-2B)	#20 SAE (1-5/8"-12UN-2B)
2	Rear	3/4" NPT	1" NPT
3	Side	3/4" SAE 4-Bolt	1-1/4" SAE 4-Bolt
4	Side	3/4" NPT	1" NPT
5	Side	#12 SAE (1-1/16"-12UN-2B)	#20 SAE (1-5/8"-12UN-2B)
6	Rear	#12 SAE (1-1/16"-12UN-2B)	#16 SAE (1-5/16"-12UN-2B)
7	Rear	3/4" BSPT	1" BSPT
8	Side	3/4" BSPT	1" BSPT
9	Side	#16 SAE (1-5/16"-12UN-2B)	#20 SAE (1-5/8"-12UN-2B)
10	Side/Rear	#12 SAE (1-1/16"-12UN-2B)	1-1/4" 4-Bolt
11	Side	#12 SAE (1-1/16"-12UN-2B)	1-1/4" 4-Bolt

UM16 FLANGE	
Code	Mounting
D	SAE 'A' 2-Bolt
E	6-Bolt Round
F	Pad (Foot) Mount
G	SAE 'C' 4-Bolt
J	SAE 'B' 4-Bolt
N	SAE 'B' 2-Bolt

M20 / SPM20 FLANGE	
Code	Mounting
D	SAE 'C' 4-Bolt
E	SAE 'B' 4-Bolt
F	SAE 'C' 2-Bolt
M	Pad (Foot) Mount
N	SAE 'B' 2-Bolt

M25 / TM25 / SPM25 FLANGE	
Code	Mounting
E	SAE 'C' 4-Bolt
F	SAE 'C' 2-Bolt

Specifications for UM16 Series

UM16 Features Include:

- Uni- (single) Rotation Motor Rotation must be specified.
- Motor does not have a bearing drain and is not suitable for series operation.
- Journal bearings for long life and good over-hung load capability
- Buna-N Seals are standards for petroleum and glycol based fluids “Viton®” seals are optional.
- Pressure balanced plates for greater efficiency.

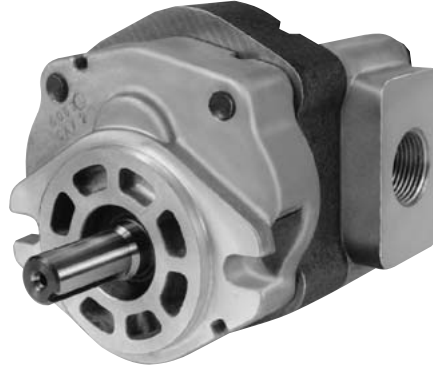

Description Gear Motors
 Flow Range To 42 GPM (158.9 LTR)
 Displacements To 3.90 C.I.R. (63.98 CC's/REV.)
 Maximum Pressure to 3000 PSI (207 BAR)
 Maximum Speed to 3600 RPM
 Rotation Uni-(Single) Direction
 Bearings Journal
 Construction Aluminum Flange & Cover
 with Cast Iron Gear Section

Performance Data

MOTOR MODELS	DISPLACEMENT/REVOLUTION (THEORETICAL)					TORQUE PER 1000 PSID*				POWER AT MAX.		MAXIMUM LIMITS				
	US GALLONS	CUBIC INCHES	LITERS	CUBIC CM'S	IMPERIAL GALLONS	START		RUN		RPM/MAX.PSID*		RELIEF SETTING		CONTINUOUS		
						LB.IN.	NM	LB.IN.	NM	H.P.	KW	PSI	BAR	PSI	BAR	RPM
UM16 - 45	0.0038	0.878	0.014	14.39	0.003	108	146	125	169	21	15.6	3000	207	1700	117	3600
UM16 - 65	0.0055	1.270	0.021	20.81	0.005	156	211	181	245	30	22.4	3000	207	1700	117	3600
UM16 - 85	0.0072	1.663	0.027	27.25	0.006	205	277	236	319	38	28.3	3000	207	1700	117	3400
UM16 - 100	0.0085	1.964	0.032	32.18	0.007	241	326	279	378	43	32.1	3000	207	1700	117	3300
UM16 - 115	0.0097	2.241	0.037	36.72	0.008	276	374	318	431	47	35.0	3000	207	1700	117	3100
UM16 - 150	0.0127	2.934	0.048	48.08	0.011	361	489	417	565	55	41.0	3000	207	1700	117	2800
UM16 - 180	0.0152	3.511	0.058	57.54	0.013	432	585	499	676	59	44.0	2200	152	1700	117	2500
UM16 - 200	0.0169	3.904	0.064	63.98	0.014	480	651	555	752	66	49.2	2000	138	1700	117	2500

Notes: (1) All data based on SAE 10W Oil at 135°F. (2) All motors are available with Viton® Seals.
 *Average values from performance curves.



CAUTION: UM16 motors do not have an external bearing drain. Return line pressure must not exceed 20 PSIG.

MOUNTING DIMENSIONS								
MOTOR MODEL	FLANGE TYPE						SHIPPING WEIGHTS LBS. KGS.	
	D		E		F			
	A	B	A	B	A	B		
UM16-45	89.9 (3.54)	115.6 (4.55)	118.4 (4.66)	144.1 (5.67)	92.9 (3.66)	118.6 (4.67)	8	3.5
UM16-65	95.3 (3.75)	121.2 (4.77)	123.6 (4.88)	149.6 (5.89)	98.6 (3.88)	124.2 (4.89)	8	3.5
UM16-85	100.9 (3.97)	126.5 (4.98)	129.3 (5.09)	154.9 (6.10)	103.9 (4.09)	129.5 (5.10)	8	3.5
UM16-100	104.9 (4.13)	130.6 (5.14)	133.3 (5.25)	159.0 (6.26)	107.9 (4.25)	133.6 (5.26)	9	4.0
UM16-115	108.9 (4.29)	134.6 (5.30)	137.4 (5.41)	163.1 (6.42)	112.0 (4.41)	137.7 (5.42)	9	4.0
UM16-150	118.4 (4.66)	144.1 (5.67)	146.8 (5.78)	172.5 (6.79)	121.4 (4.78)	147.1 (5.79)	9	4.0
UM16-180	126.5 (4.98)	152.2 (5.99)	154.9 (6.10)	180.6 (7.11)	129.5 (5.10)	155.2 (6.11)	10	4.5
UM16-200	131.8 (5.19)	157.5 (6.20)	160.3 (6.31)	185.9 (7.32)	134.9 (5.31)	160.5 (6.32)	10	4.5

MOUNTING DIMENSIONS								
MOTOR MODEL	FLANGE TYPE						SHIPPING WEIGHTS LBS. KGS.	
	J		N		S			
	A	B	A	B	A	B		
UM16-45	118.4 (4.66)	144.1 (5.67)	86.9 (3.42)	112.5 (4.43)	132.6 (5.22)	158.2 (6.23)	8	3.5
UM16-65	123.6 (4.88)	149.6 (5.89)	92.2 (3.63)	118.1 (4.65)	138.2 (5.44)	163.8 (6.45)	8	3.5
UM16-85	129.3 (5.09)	154.9 (6.10)	97.8 (3.85)	123.4 (4.86)	143.5 (5.65)	169.2 (6.66)	8	3.5
UM16-100	133.3 (5.25)	159.0 (6.26)	101.8 (4.01)	127.5 (5.02)	147.6 (5.81)	173.2 (6.82)	9	4.0
UM16-115	137.4 (5.41)	163.1 (6.42)	105.9 (4.17)	131.6 (5.18)	151.6 (5.97)	177.3 (6.98)	9	4.0
UM16-150	146.8 (5.78)	172.5 (6.79)	115.3 (4.54)	140.9 (5.55)	161.0 (6.34)	186.7 (7.35)	9	4.0
UM16-180	154.9 (6.10)	180.6 (7.11)	123.4 (4.86)	149.1 (5.87)	169.2 (6.66)	194.8 (7.67)	10	4.5
UM16-200	160.3 (6.31)	185.9 (7.32)	128.8 (5.07)	154.4 (6.08)	174.5 (6.87)	200.1 (7.88)	10	4.5

C DIMENSIONS		
FLANGE TYPE	MM	IN
D	6.35	(.250)
E	4.74	(.187)
F	—	—
G	6.35	(.250)
J	6.35	(.250)
N	9.52	(.375)
S	5.08	(.200)

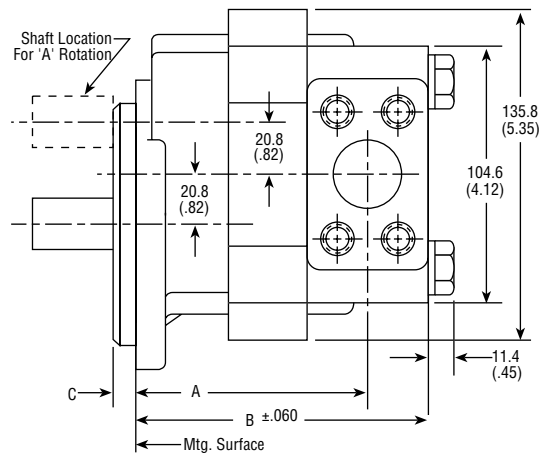

Inch equivalents for millimeter dimensions are shown in (**).

Specifications for M20 Series

M20 Features Include:

- Bearing drain is standard and allows operation in series circuits.
- Journal bearings for long life and good over-hung load capability
- Buna-N Seals are standards for petroleum and glycol based fluids “Viton®E” seals are optional.
- Pressure balanced plates for greater efficiency.

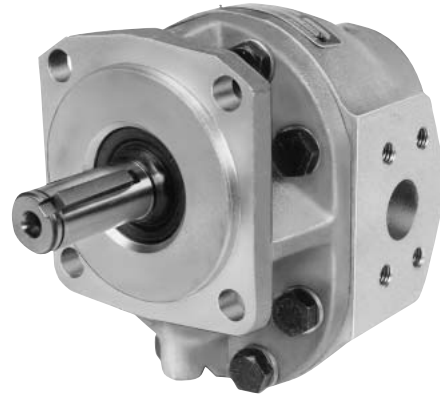

Description Gear Motors
 Flow Range To 98 GPM (370.9 LTR)
 Displacements To 9.10 C.I.R. (149.12 cc's / rev.)
 Maximum Pressure to 2500 PSI (172 BAR)
 Maximum Speed to 2500 RPM
 Rotation Bi-Directional
 Bearings Journal
 Construction Aluminum

Performance Data

MOTOR MODELS	DISPLACEMENT/REVOLUTION (THEORETICAL)					TORQUE PER 1000 PSID*				POWER AT MAX.		MAXIMUM LIMITS				
	US GALLONS	CUBIC INCHES	LITERS	CUBIC CM'S	IMPERIAL GALLONS	START		RUN		RPM/MAX.PSID*		RELIEF SETTING		CONTINUOUS		
						LB.IN.	NM	LB.IN.	NM	H.P.	KW	PSI	BAR	PSI	BAR	RPM
M20150	.0131	3.02	.050	49.85	.011	272	368	400	542	38	28.3	2500	172	1700	117	2500
M20200	.0175	4.04	.066	66.20	.015	384	520	588	797	50	37.3	2500	172	1700	117	2500
M20250	.0219	5.06	.083	82.92	.018	496	672	720	976	64	47.7	2500	172	1700	117	2500
M20300	.0262	6.05	.099	99.14	.022	608	824	880	1193	74	55.2	2500	172	1700	117	2500
M20350	.0306	7.07	.116	115.86	.025	720	976	1000	1355	90	67.1	2500	172	1700	117	2500
M20400	.0350	8.08	.133	132.41	.029	820	1111	1120	1518	105	78.3	2500	172	1700	117	2500
M20450	.0394	9.10	.149	149.12	.033	940	1274	1340	1816	124	92.5	2500	172	1700	117	2500

*Average values from performance curves.
 Available with Viton® Seals. All data based on SAE 10W oil at 135°F.



CAUTION: “If return line pressure exceeds 150 PSIG, the external bearing drain must be used.

MOTOR MODEL			SAE 4-BOLT CONN. PORT				Shipping Weights	
	For 'C' 2-Bolt & 'B' & 'C' 4-Bolt Fig.		Inlet		Outlet		lbs.	kgs.
	A	B	Conn. Sz.	Hole Dia.	Conn. Sz.	Hole Dia.		
M20150	104.6 (4.12)	167.8 (6.61)	1"	25.4 (1.00)	1"	25.4 (1.00)	19	8.62
M20200	104.6 (4.12)	167.8 (6.61)	1"	25.4 (1.00)	1"	25.4 (1.00)	20	9.07
M20250	104.6 (4.12)	167.8 (6.61)	1-1/4"	30.2 (1.25)	1-1/4"	30.2 (1.25)	21	9.53
M20300	104.6 (4.12)	167.8 (6.61)	1-1/4"	30.2 (1.25)	1-1/4"	30.2 (1.25)	22	9.98
M20350	110.4 (4.35)	182.3 (7.18)	1-1/2"	38.1 (1.50)	1-1/2"	38.1 (1.50)	23	10.4
M20400	110.4 (4.35)	189.7 (7.47)	1-1/2"	38.1 (1.50)	1-1/2"	38.1 (1.50)	24	10.9
M20450	118.3 (4.66)	196.8 (7.75)	1-1/2"	38.1 (1.50)	1-1/2"	38.1 (1.50)	25	11.3

SAE 4-Bolt Connector Ports					
Size	C	D	E	F	G
1"	12.9 (.51)	26.1 (1.031)	26.1 (1.03)	52.3 (2.062)	3/8-16NC
1-1/4"	14.9 (.59)	30.1 (1.188)	29.2 (1.15)	58.7 (2.313)	7/16-14NC
1-1/2"	17.7 (.70)	35.7 (1.406)	34.7 (1.37)	69.8 (2.750)	1/2-13NC

Inch equivalents for millimeter dimensions are shown in (**).

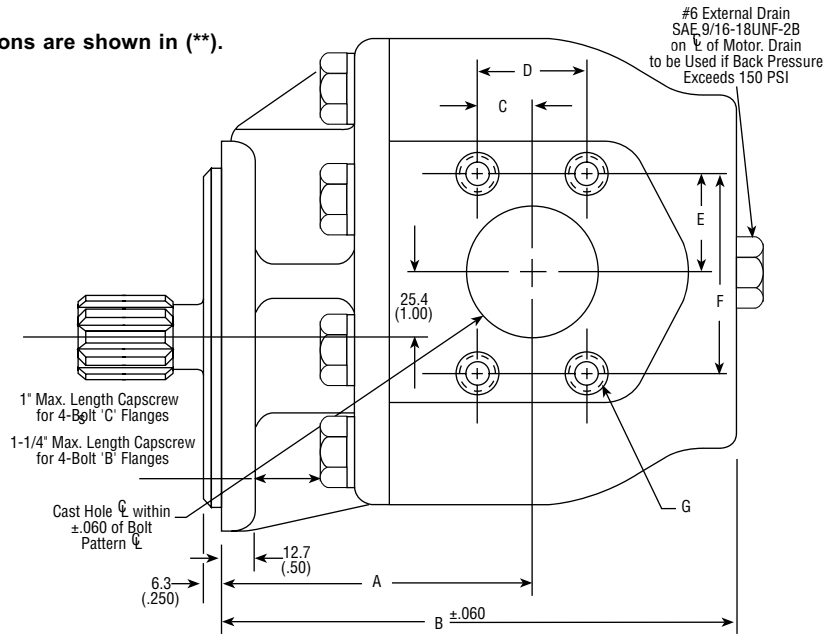

Specifications for SPM20 Series

SPM20 Features Include:

- Tandem motor with valving to provide two-speed operation on constant input flow
- Journal bearings for long life and good over-hung load capability
- Buna-N Seals are standards for petroleum and glycol based fluids “Viton®E” seals are optional.
- Pressure balanced plates for greater efficiency.



Description Two-Speed Gear Motors
 Flow Range To 98 GPM Per Section (370.9 LTR)
 Displacements To 9.10 C.I.R. Per Section (149.12 cc's/rev.)
 Maximum Pressure to 2500 PSI (172 BAR)
 Maximum Speed to 2500 RPM
 Rotation Bi-Directional
 Bearings Journal
 Construction Aluminum

Tandem Motor With Valving To Provide Two-Speed Operation On Constant Input Flow

Parker two-speed motors consist of two hydraulic motor units and pilot operated valving. From this unique unit either high speed or high torque can be obtained, thereby improving the efficiency of winch drives, track drives, and hydrostatic transmissions. Main features of these units are: no external pilot pressure source is necessary, shift to different speed is extremely smooth; and the motor will not hesitate during shift. Displacement of the two motors need not be equal. It utilizes one inlet and one outlet and is fully reversible.

The two motor sections are connected through valving to the common inlet/outlet ports. For low-speed, high-torque output, the pilot port is vented to the tank. For higher-speed, lower torque, the pilot port is blocked, causing the internal valves to shift to the closed position, routing the total flow through the rear motor section. The front motor section receives lubrication oil through the valve section, and requires very little horsepower in this position, since it is only recirculating the fluid.

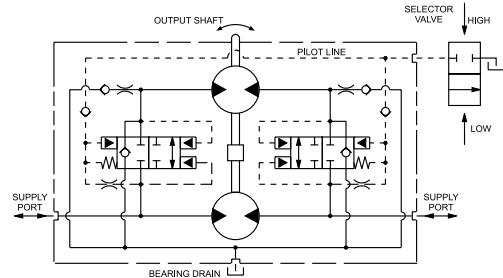

Inch equivalents for millimeter dimensions are shown in (**).

Performance Data Per Section

MOTOR MODELS	DISPLACEMENT/REVOLUTION(THEORETICAL)					TORQUE PER 1000 PSID*				POWER AT MAX.		MAXIMUM LIMITS					
	US GALLONS	CUBIC INCHES	LITERS	CUBIC CM'S	IMPERIAL GALLONS	START		RUN		RPM/MAX.PSID*	H.P.	KW	RELIEF SETTING		CONTINUOUS		
						LB.IN.	NM	LB.IN.	NM				PSI	BAR	PSI	BAR	RPM
SPM20150	.0131	3.02	.050	49.85	.011	272	368	400	542	38	28.3	2500	172	1700	117	2500	
SPM20200	.0175	4.04	.066	66.20	.015	384	520	588	797	50	37.3	2500	172	1700	117	2500	
SPM20250	.0219	5.06	.083	82.92	.018	496	672	720	976	64	47.7	2500	172	1700	117	2500	
SPM20300	.0262	6.05	.099	99.14	.022	608	824	880	1193	74	55.2	2500	172	1700	117	2500	
SPM20350	.0306	7.07	.116	115.86	.025	720	976	1000	1355	90	67.1	2500	172	1700	117	2500	
SPM20400	.0350	8.08	.133	132.41	.029	820	1111	1120	1518	105	78.3	2500	172	1700	117	2500	
SPM20450	.0394	9.10	.149	149.12	.033	940	1274	1340	1816	124	92.5	2500	172	1700	117	2500	

*Average values from performance curves.
 Available with Viton® Seals. All data based on SAE 10W oil at 135°F.

CAUTION: Bearing drain line must not exceed 20 PSIG.

MOUNTING DIMENSIONS		
MOTOR SIZES	A	B
SPM20150-150	203.9 (8.03)	322.0 (12.68)
SPM20200-200	226.8 (8.93)	366.5 (14.43)
SPM20250-250	233.9 (9.21)	383.7 (15.11)
SPM20300-300	241.0 (9.49)	398.0 (15.67)
SPM20350-350	248.4 (9.78)	395.4 (15.57)
SPM25400-400	255.5 (10.06)	409.7 (16.13)
SPM20450-450	262.8 (10.35)	424.4 (16.71)

SAE 4-Bolt Connector Ports					
Size	C	D	E	F	G
1-1/2"	17.7 (.70)	35.7 (1.406)	34.7 (1.37)	69.8 (2.750)	1/2-13NC

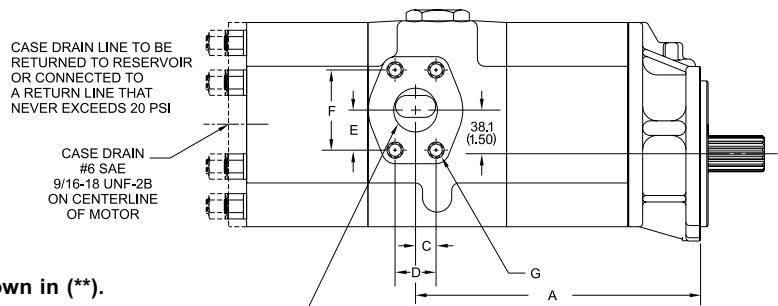

Inch equivalents for millimeter dimensions are shown in (**).

SAE 4-Bolt NPT Connectors are available. See Accessory Section.

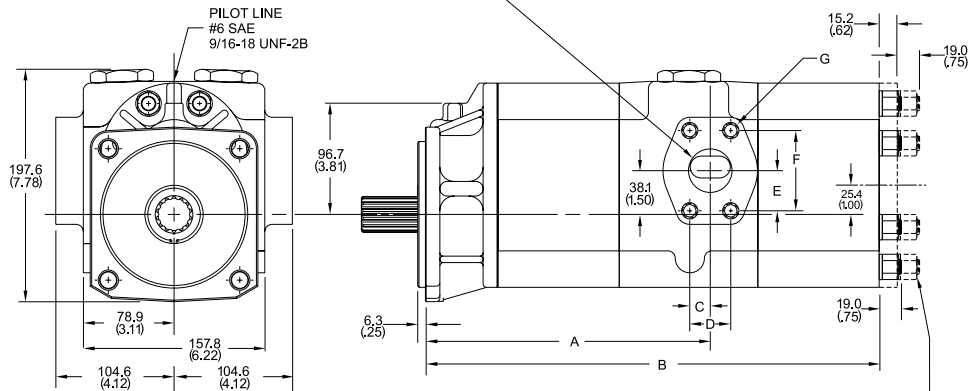

Note: Any pump combination with 350, 400 or 450 sections on the rear, will use a cover plate as shown by the dotted line.

Specifications for M25 Series

M25 Features Include:

- Bearing Drain is standard and allows operation in series circuits
- Journal bearings for long life and good over-hung load capability
- Buna-N Seals are standards for petroleum and glycol based fluids “Viton®E” seals are optional.
- Pressure balanced plates for greater efficiency.

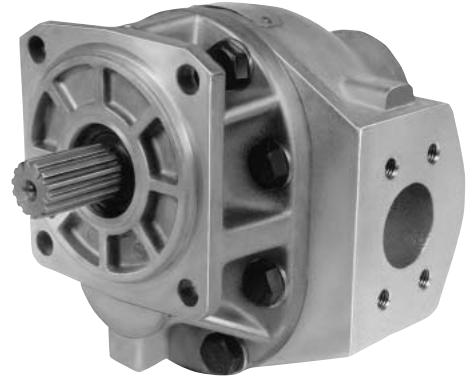

Description Gear Motors
 Flow Range To 166 GPM (628.3 LTR.)
 Displacements To 19.22 C.I.R. (314.96 CC's/REV.)
 Maximum Pressure to 2500 PSI (172 BAR)
 Maximum Speed to 2000 RPM
 Rotation Bi-Directional
 Bearings Journal
 Construction Aluminum

Performance Data

MOTOR MODELS	DISPLACEMENT/REVOLUTION(THEORETICAL)					TORQUE PER 1000 PSID*				POWER AT MAX. RPM/MAX.PSID*		MAXIMUM LIMITS				
	US GALLONS	CUBIC INCHES	LITERS	CUBIC CM'S	IMPERIAL GALLONS	START		RUN		H.P.	KW	RELIEF SETTING		CONTINUOUS		
						LB.IN.	NM	LB.IN.	NM			PSI	BAR	PSI	BAR	RPM
M25550	.0479	11.06	.181	181.24	.040	1400	1898	1600	2169	122	91.0	2500	172	1700	117	2000
M25660	.0581	13.42	.220	219.91	.048	1760	2386	1960	2657	146	109.0	2500	172	1700	117	2000
M25770	.0671	15.50	.254	254.00	.056	1820	2467	2200	1629	168	125.3	2500	172	1700	117	2000
M25950	.0832	19.22	.315	314.96	.069	2295	3111	2818	1873	187	139.4	2200	152	1700	117	2000

All data based on SAE 10W oil at 135°F. Available with Viton® .
 *Average values from performance curves. **At 2200 PSI.



CAUTION: If return line pressure exceeds 150 PSIG, the external bearing drain must be used.

MOUNTING DIMENSIONS						
Motor Model	For 'C' 2-Bolt & 'B' & 'C' 4-Bolt Flg.		SAE 4-Bolt Conn. Port		Shipping Weights	
	A	B	Inlet	Outlet	lbs.	kgs.
M20550	128.5 (5.06)	223.7 (8.81)	2"	2"	45	20.41
M20660	134.8 (5.31)	230.1 (9.06)	2"	2"	46	20.87
M20770	141.2 (5.56)	236.4 (9.31)	2"	2"	48	21.77
M20950	157.7 (6.21)	252.7 (9.95)	2"	2"	49	22.23

SAE 4-Bolt Connector Ports					
Size	C	D	E	F	G
2"	21.3 (.84)	42.8 (1.688)	38.8 (1.53)	77.7 (3.062)	1/2-13NC

Inch equivalents for millimeter dimensions are shown in (**).

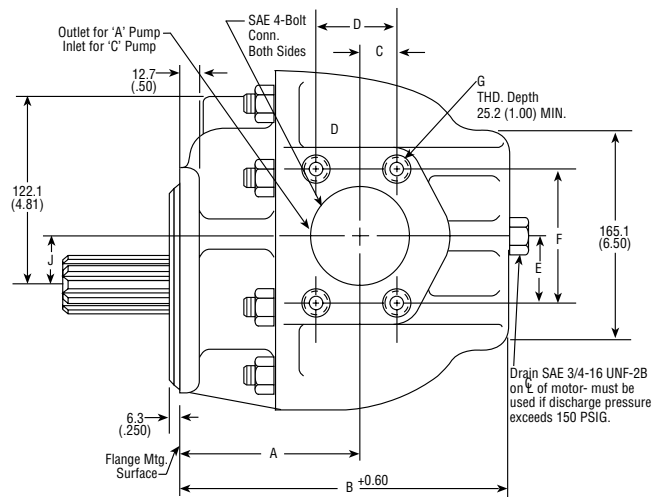
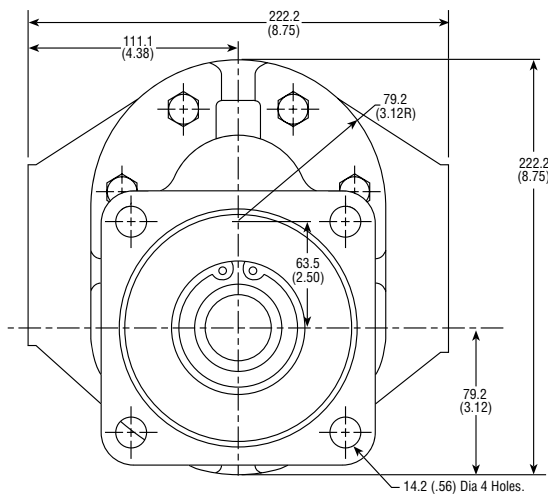

SAE 4-Bolt NPT Connectors are available. See Accessory Section

Specifications for TM25 Series

TM25 Features Include:

- Bearing drain is standard and allows operation in series circuits
- Journal bearings for long life and good over-hung load capability
- Buna-N Seals are standards for petroleum and glycol based fluids "Viton®E" seals are optional.
- Pressure balanced plates for greater efficiency.



Description Gear Motors
 Flow Range To 134 GPM Per Section (507.2 LTR.)
 Displacements To 15.50 C.I.R. Per Section (254.00 CC's/REV.)
 Maximum Pressure to 2500 PSI (172 BAR)
 Maximum Speed to 2000 RPM
 Rotation Bi-Directional
 Bearings Journal
 Construction Aluminum

Performance Data Per Section

MOTOR MODELS	DISPLACEMENT/REVOLUTION(THEORETICAL)					TORQUE PER 1000 PSID*				POWER AT MAX.		MAXIMUM LIMITS				
	US GALLONS	CUBIC INCHES	LITERS	CUBIC CM'S	IMPERIAL GALLONS	START		RUN		RPM/MAX.PSID*		RELIEF SETTING		CONTINUOUS		
						LB.IN.	NM	LB.IN.	NM	H.P.	KW	PSI	BAR	PSI	BAR	RPM
TM25550	.0479	11.06	.181	181.24	.040	1400	1898	1600	2169	122	91.0	2500	172	1700	117	2000
TM25660	.0581	13.42	.220	219.91	.048	1760	2386	1960	2657	146	109.0	2500	172	1700	117	2000
TM25770	.0671	15.50	.254	254.00	.056	1820	2467	2200	1629	168	125.3	2500	172	1700	117	2000

All data based on SAE 10W oil at 135°F.*Average values from performance curves.



CAUTION: If return line pressure exceeds 150 PSIG, the external bearing drain must be used.

MOUNTING DIMENSIONS

PUMP SIZE	For 'C' 2-Bolt & 'C' 4-Bolt Flg.			SAE 4-Bolt Conn. Port	
	A	B	C	Inlet	Outlet
TM25550-550	128.5 (5.06)	376.1 (14.81)	471.4 (18.56)	2"	2"
TM25660-550	137.9 (5.43)	386.8 (15.23)	482.0 (18.98)	2"	2"
TM25660-660	137.9 (5.43)	393.1 (15.48)	488.4 (19.23)	2"	2"
TM25770-550	147.5 (5.81)	396.2 (15.60)	491.4 (19.35)	2"	2"
TM25770-660	147.5 (5.81)	402.5 (15.85)	497.8 (19.60)	2"	2"
TM25770-770	147.5 (5.81)	408.9 (16.10)	504.1 (19.85)	2"	2"

SAE 4-Bolt Connector Ports

Size	D	E	F	G	H
2"	21.3 (.84)	42.8 (1.688)	38.8 (1.53)	77.7 (3.062)	1/2-13NC

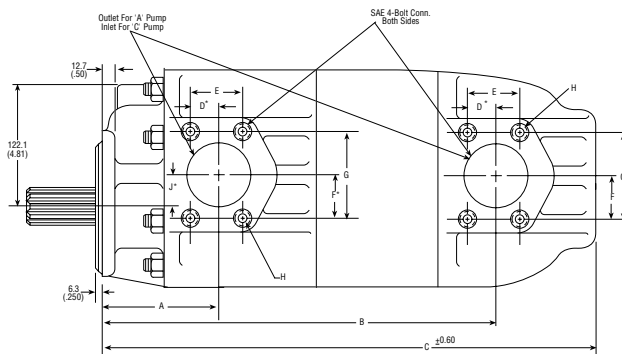
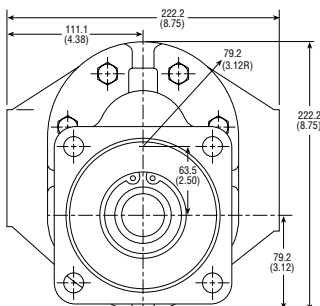

Inch equivalents for millimeter dimensions are shown in (**).

Specifications for SPM25 Series

SPM25 Features Include:

- Tandem motor with valving to provide two-speed operation on constant input flow
- Journal bearings for long life and good over-hung load capability
- Buna-N Seals are standards for petroleum and glycol based fluids “Viton®E” seals are optional.
- Pressure balanced plates for greater efficiency.

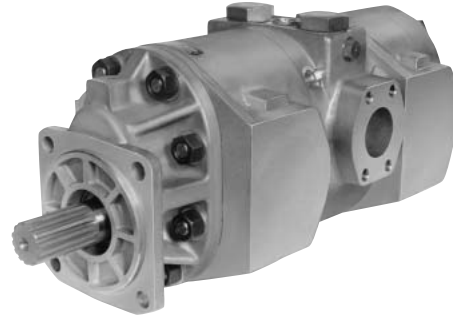

Description	Two-Speed Gear Motors
Flow Range	To 134 GPM (507.2 LTR) per Section
Displacements	To 15.50 CIR. (240 CC's/REV.) per Section
Maximum Pressure to	2500 PSI (172 BAR)
Maximum Speed to	2000 RPM
Rotation	Bi-Directional
Bearings	Journal
Construction	Aluminum

Tandem Motor With Valving To Provide Two-Speed Operation On Constant Input Flow

Parker two-speed motors consist of two hydraulic motor units and pilot-operated valving. From this unique unit either high-speed or high torque can be obtained, thereby improving the efficiency of winch drives, track drives, and hydrostatic transmissions. Main features of these units are: no external pilot pressure source is necessary, shifting to different speed is extremely smooth; the motor will not hesitate during shift. Displacement of the two motors need not be equal. It utilizes one inlet and one outlet, and is fully reversible.

The two, motor sections are connected through valving to the common inlet/outlet ports. For low-speed, high-torque output, the pilot port is vented to tank. For higher speed, lower torque, the pilot port is blocked, causing the internal valves to shift to the closed position, routing the total flow through the rear motor section. The front motor section receives lubrication oil through the valve section, and requires very little horsepower in this position, since it is only recirculating the fluid.

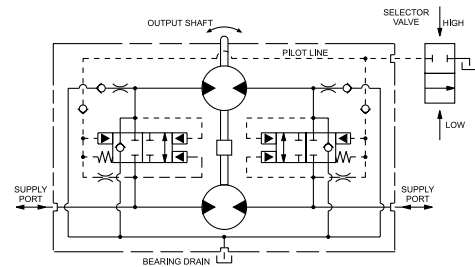

Performance Data Per Section

MOTOR MODELS	DISPLACEMENT/REVOLUTION(THEORETICAL)					TORQUE PER 1000 PSID*				POWER AT MAX.		MAXIMUM LIMITS				
	US GALLONS	CUBIC INCHES	LITERS	CUBIC CM'S	IMPERIAL GALLONS	START		RUN		RPM/MAX.PSID*		RELIEF SETTING		CONTINUOUS		
						LB.IN.	NM	LB.IN.	NM	H.P.	KW	PSI	BAR	PSI	BAR	RPM
SPM25500	.0435	10.04	.165	164.52	.036	1400	1898	1600	2169	122	91.0	2500	172	1700	117	2000
SPM25550	.0479	11.06	.181	181.24	.040	1760	2386	1960	2657	146	109.0	2500	172	1700	117	2000
SPM25660	.0581	13.42	.220	219.91	.048	1820	2467	2200	2982	168	125.3	2500	172	1700	117	2000
SPM25770	.0671	15.50	.254	254.00	.056	2295	3111	2818	3820	187	139.4	2500	172	1700	117	2000

All data based on SAE 10W oil at 135°F. Available with Viton® Seals.
 *Average values from performance curves.

CAUTION: Bearing drain line must not exceed 20 PSIG.

MOUNTING DIMENSIONS		
MOTOR SIZES	FOR 'C' 2-BOLT & 'C' 4-BOLT	
	A	B
SPM25500-500	270.2 (10.64)	451.1 (17.76)
SPM25500-550	270.2 (10.64)	455.6 (17.94)
SPM25500-660	270.2 (10.64)	465.0 (18.31)
SPM25500-770	270.2 (10.64)	482.0 (18.98)
SPM25550-500	274.8 (10.82)	455.6 (17.94)
SPM25550-550	274.8 (10.82)	460.2 (18.12)
SPM25550-660	274.8 (10.82)	469.6 (18.49)
SPM25550-770	274.8 (10.82)	486.6 (19.16)
SPM25660-500	285.4 (11.24)	466.3 (18.36)
SPM25660-550	285.4 (11.24)	470.9 (18.54)
SPM25660-660	285.4 (11.24)	480.3 (18.91)
SPM25660-770	285.4 (11.24)	497.3 (19.58)
SPM25770-500	294.8 (11.61)	475.7 (18.73)
SPM25770-550	294.8 (11.61)	480.3 (18.91)
SPM25770-660	294.8 (11.61)	489.7 (19.28)
SPM25770-770	294.8 (11.61)	506.7 (19.95)

SAE 4-Bolt NPT Connectors are available. See Accessory Section

MOUNTING DIMENSIONS					
SIZE	C	D	E	F	G
2"	84 (21.3)	42.8 (1.688)	38.8 (1.53)	77.7 (3.062)	1/2-13NC

Inch equivalents for millimeter dimensions are shown in (**).

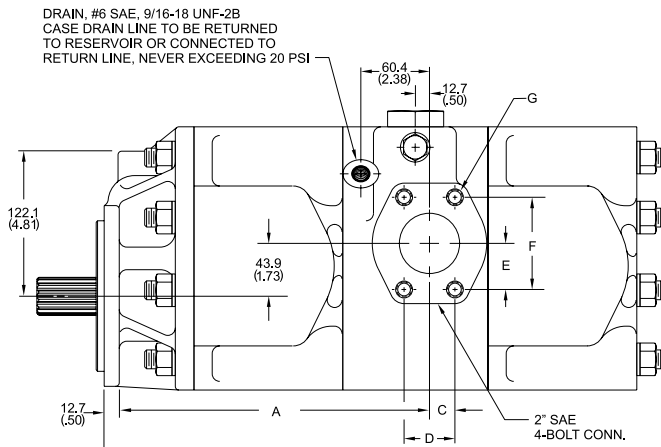
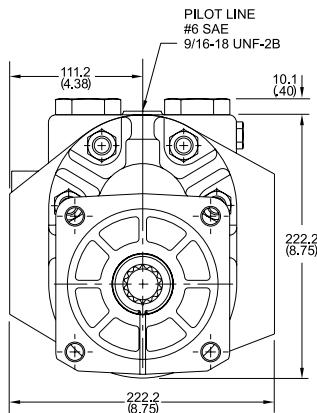
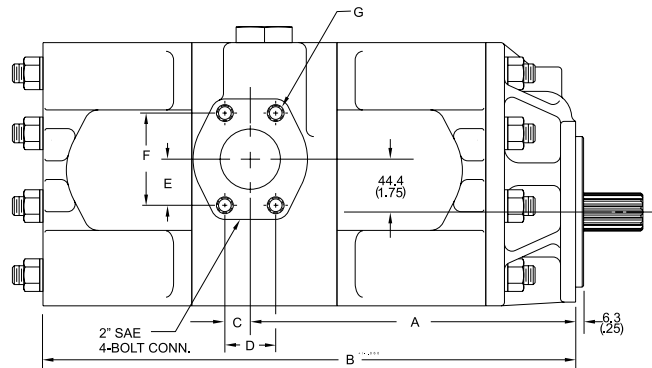

Shafts Available for UM16 Motor Series

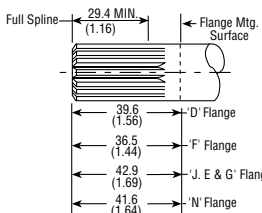
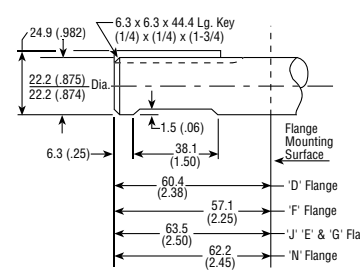
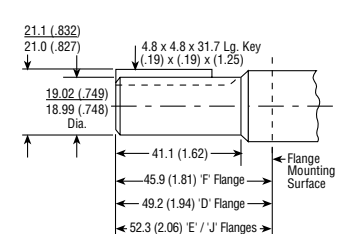
<p>2 7/8" Dia. 13-Tooth Spline Flat Root Side Fit Torque Limit 184 Lbs. Ft. (249.4 Nm) Available in all sizes and flanges</p>  <p>Spline Data Diametral Pitch 16/32 Pressure Angle 30° No. Of Teeth 13</p>	<p>5 7/8" Straight Shaft Flat Root Side Fit Torque Limit 184 Lbs. Ft. (249.4 Nm) Available in all sizes and flanges</p> 	<p>6 3/4" Straight Shaft Torque Limit 105 Lbs. Ft. (142.3 Nm) Available in sizes UM16 thru UM16-115 only and all flanges</p> 
---	---	--

Shafts Available for M20 & SPM20 Motor Series

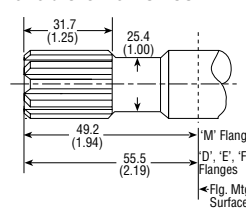
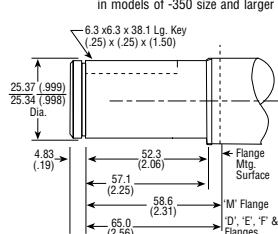
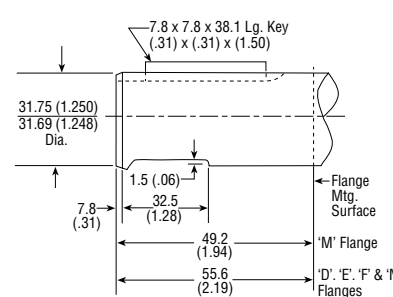
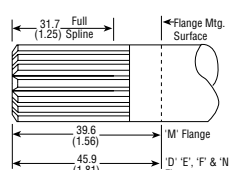
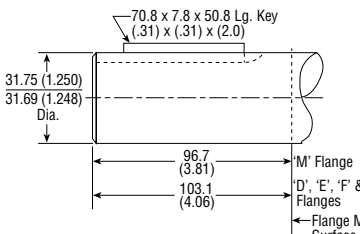
<p>1 SAE 'C' 1-1/4" 14-Tooth Spline Flat Root Side Fit Torque Limit 655 Lbs. Ft. (888. Nm) "Single" Motors only Available on all sizes</p>  <p>Spline Data Diametral Pitch 12/24 Pressure Angle 30° No. Of Teeth 13</p>	<p>2 1" Dia. Straight Shaft Torque Limit 341 Lbs. Ft. (462.3 Nm) Available on M20100 thru M20350 only</p> <p>CAUTION: Due to shaft torque limitations, Consult the Factory for approval before applying this shaft in models of -350 size and larger pumps.</p> 	<p>3 SAE 'C' 1-1/4" Straight Shaft Torque Limit 655 Lbs. Ft. (888. Nm) Available on all sizes</p> 
<p>4 7/8" Dia. 13-Tooth Spline Flat Root Side Fit Torque Limit 184 Lbs. Ft. (249.4 Nm) Available on M20100 thru M20350 only</p>  <p>Spline Data Diametral Pitch 16/32 Pressure Angle 30° No. Of Teeth 14</p>	<p>5 1-1/4" Straight Shaft Torque Limit 655 Lbs. Ft. (888. Nm) Available on all sizes</p> 	<p>Inch equivalents for millimeter dimensions are shown in (**).</p>

Shafts Available for M25 Motor Series

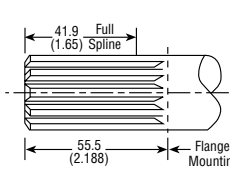
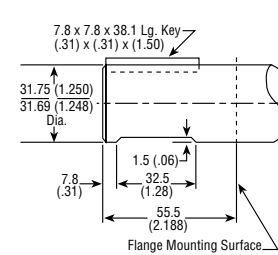
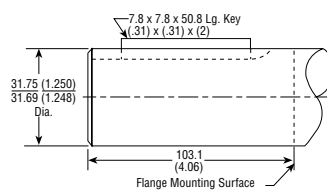
<p>1 SAE 'C' 1-1/4" 14 Tooth Spline Flat Root Side Fit Torque limit 655 Lbs. Ft. (888.0 Nm) Available for all single section sizes</p>  <p>Spline Data Diametral Pitch 12/24 Pressure Angle 30° No. Of Teeth 14</p>	<p>2 SAE 'C' 1-1/4" Straight Shaft Torque limit 655 Lbs. Ft. (888.0 Nm) Available for all single section sizes only</p> 	<p>5 1-1/4" Straight Shaft Torque limit 655 Lbs. Ft. (888.0 Nm) Available for all single section sizes only</p> 
--	---	---

Shafts Available for TM25 & SPM25 Motor Series

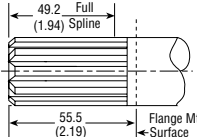
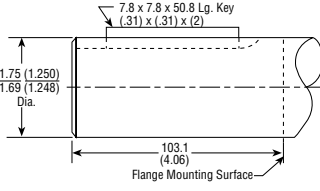
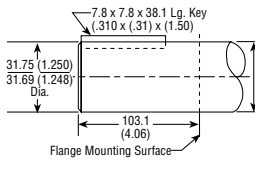
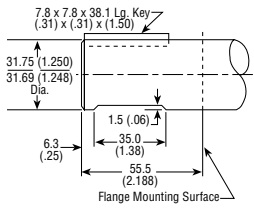
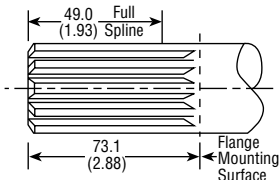
<p>1 SAE 'C' 1-1/4" 14-Tooth Spline Flat Root Side Fit Torque Limit 655 Lbs. Ft. (888. Nm) "Tandem" Pumps Only Available for SPM25450, SPM25500 and SPM2550 only</p>  <p>Spline Data Diametral Pitch 12/24 Pressure Angle 30° No. Of Teeth 14</p>	<p>5 1-1/4" Straight Shaft Torque Limit 655 Lbs. Ft. (888. Nm) TM25 & SPM25 Motors available in 450, 500, 550, 660 & 770 sizes only</p> 	<p>7 1-1/2" Dia. Straight Shaft Torque Limit 1180 Lbs. Ft. (1600 Nm) TM25 & SPM25 Motors available in 450, 500, 550, 660 & 770 sizes only</p> 
<p>9 1-1/2" Dia. Straight Shaft Torque Limit 1180 Lbs. Ft. (1600 Nm) TM25 & SPM25 Motors available in 450, 500, 550, 660 & 770 sizes only</p> 	<p>9 1-1/2" 17-Tooth Spline Flat Root Side Fit Torque Limit 1180 Lbs. Ft. (1600 Nm) TM25 & SPM25 Motors available in 450, 500, 550, 660 & 770 sizes only</p>  <p>Spline Data Diametral Pitch 10/20 Pressure Angle 30° No. Of Teeth 14</p>	<p>Inch equivalents for millimeter dimensions are shown in (**).</p>

Cover Plates Available for UM16 Motor Series

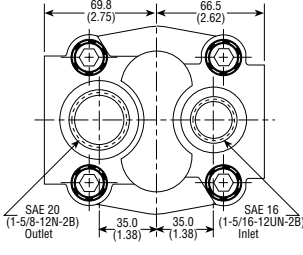
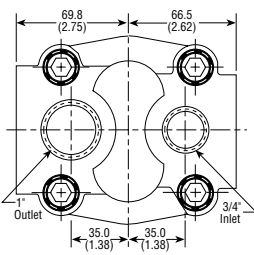
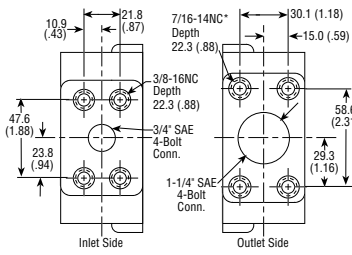
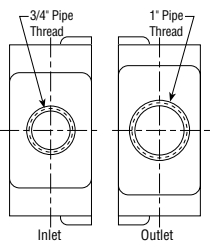
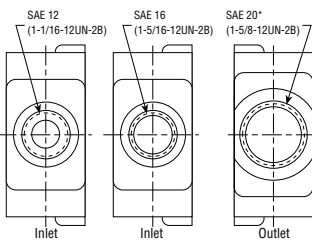
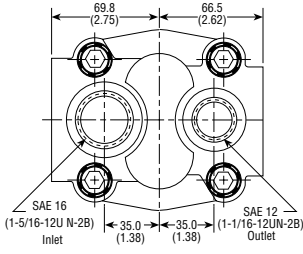
<p>1 Rear Ported Straight Thread</p> 	<p>2 Rear Ported NPT</p> <p>7 Rear Ported BSPT</p> 	<p>3 Side Ported SAE 4-Bolt Metric Threads are available – Consult factory. SAE 4-Bolt NPT Connectors Are Available. See Accessory Section.</p> 
<p>4 Side Ported NPT</p> <p>8 Side Ported BSPT</p> 	<p>5 Side Ported Straight Thread SAE 12 Discharge</p> <p>9 Side Ported Straight Thread SAE 16 Discharge</p> 	<p>6 Rear Ported Straight Thread</p> 

Mounting Flanges Available for UM16 Motor Series

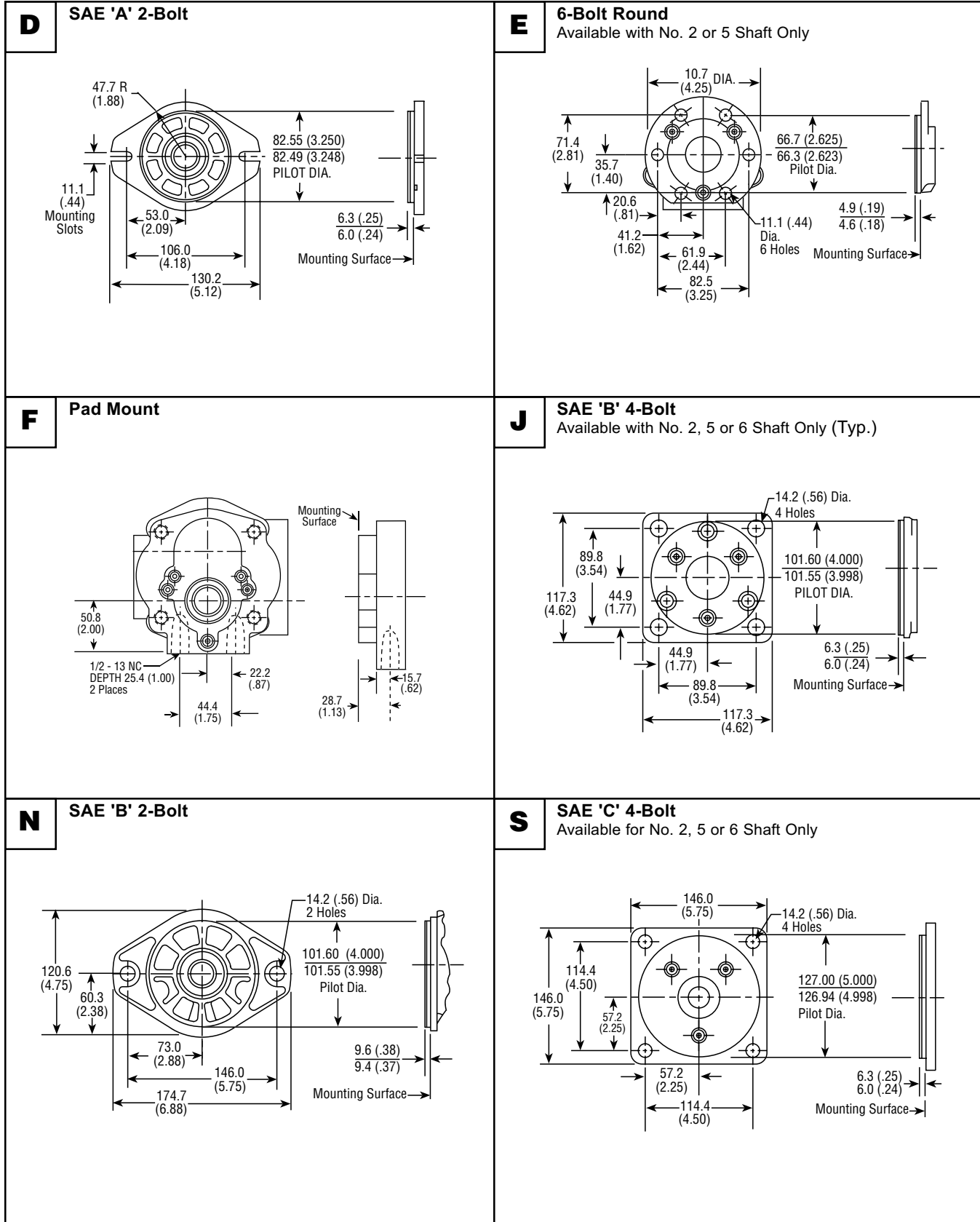

Inch equivalents for millimeter dimensions are shown in (**).

Mounting Flanges Available for M20 Motor Series

<p>M 'M' Pad Mount Available for M20 Series Only</p>	<p>D SAE 'C' 4-Bolt Available for M20 & SPM20 Series Only</p>
<p>E SAE 'B' 4-Bolt Available for M20 & SPM20 Series Only</p>	<p>F SAE 'C' 2-Bolt Available for M20, SPM20, M25, TM25 & SPM25 Series</p>
<p>N SAE 'B' 2-Bolt Available for M20 Series Only</p>	<p>E SAE 'C' 4-Bolt Available for M25 & SPM25 Series Only</p>

Inch equivalents for millimeter dimensions are shown in (**).

General Information for Dry Valve Series

- Available in various configurations:
 - DVP16 — 3 piece construction, cast iron pumping section, aluminum flange, aluminum cover
 - DV20 — 2 piece construction, all aluminum or all cast iron*
 - DV25 — 2 piece construction, all aluminum or all cast iron*
 - Valve is of separate bar stock construction for ease of maintenance.
 - Multi-section pumps are available.
 - Journal bearings for long life
 - Buna-N Seals are standard for petroleum and glycol based fluids. "Viton®E" seals are optional.
 - Pressure balanced plates for greater efficiency.
- * Cast iron not available on all models. Consult factory for availability.

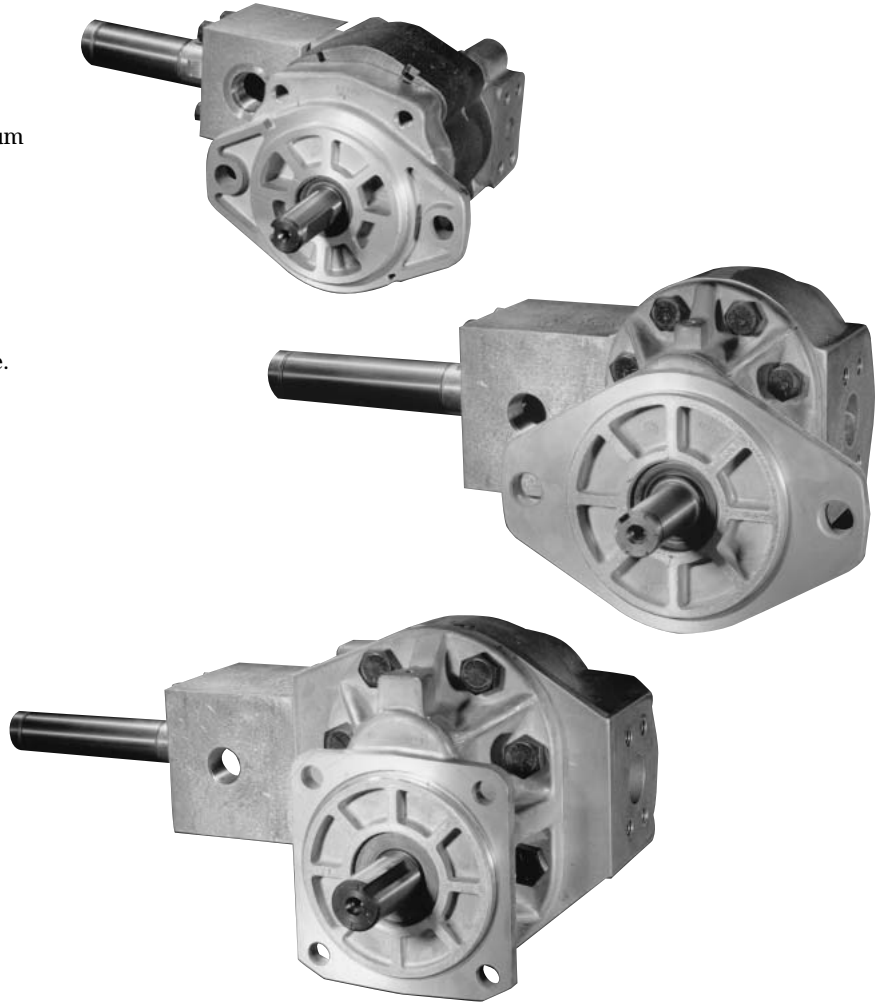

How to Order Dry Valve Series:

Select the desired symbol (in the correct position) to construct a model code.

Assembly Example:

OPTIONS	
Code	Description
V	Viton®

MODEL	
Code	Description
DV	Dry Valve Pump

DVP16

Series

SERIES	
Code	Description
DVP16	DVP16
DV20	DV20
DV25	DV25

Section Size

DVP16 SECTION SIZE		
Code	Cu. In./ Rev.	CC's/ Rev.
45	.878	14.39
65	1.270	20.81
85	1.663	27.25
100	1.964	32.18
115	2.241	36.72
150	2.934	48.08
180	3.511	57.54
200	3.904	63.98

DV20 SECTION SIZE		
Code	Cu. In./ Rev.	CC's/ Rev.
150	3.02	49.85
200	4.04	66.20
250	5.06	82.92
300	6.05	99.14
350	7.07	115.86
400	8.08	132.41
450	9.10	149.12

DV25 SECTION SIZE		
Code	Cu. In./ Rev.	CC's/ Rev.
300	6.05	99.14
350	7.07	115.86
400	8.08	132.41
450	9.10	149.12
500	10.05	164.69
550	11.06	181.24
660	18.42	219.92
770	15.50	254.00
950	19.22	314.96

Rotation

ROTATION	
Code	Direction
A	C' C' Wise
C	C' Wise

Flange Options

DVP16 FLANGE	
Code	Mounting
D	SAE 'A' 2-Bolt
E	6-Bolt Round
F	Pad (Foot) Mount
G	SAE 'C' 4-Bolt
J	SAE 'B' 4-Bolt
N	SAE 'B' 2-Bolt
S	PTO Direct
T	PTO (Chelsea T19C)

DV20 FLANGE	
Code	Mounting
D	SAE 'C' 4-Bolt
E	SAE 'B' 4-Bolt
F	SAE 'C' 2-Bolt
M	Pad (Foot) Mount
N	SAE 'B' 2-Bolt

DV25 FLANGE	
Code	Mounting
E	SAE 'C' 4-Bolt
F	SAE 'C' 2-Bolt

COVER PLATE (UM16 ONLY)			
Code	Port	Inlet	Outlet
1	Side	#20 SAE (1-5/8"-12UN-2B)	#16 SAE (1-5/16"-12UN-2B)
2	Rear	1" NPT	3/4" NPT
3	Side	1-1/4" 4-Bolt	3/4" 4-Bolt
4	Side	1" NPT	3/4" NPT
5	Side	#20 SAE (1-5/8"-12UN-2B)	#12 SAE (1-1/16"-12UN-2B)
6	Rear	#16 SAE (1-5/16"-12UN-2B)	#12 SAE (1-1/16"-12UN-2B)
7	Rear	1" BSPT	3/4" BSPT
8	Side	1" BSPT	3/4" BSPT
9	Side	#20 SAE (1-5/8"-12UN-2B)	#16 SAE (1-5/16"-12UN-2B)
10	Side/Rear	1-1/4" 4-Bolt	#12 SAE (1-1/16"-12UN-2B)
11	Side	1-1/4" 4-Bolt	#12 SAE (1-1/16"-12UN-2B)

Note: Leave Blank If Models Are DV20 or DV25.

DRY VALVE	
Code	Description
ER-125	1 1/4" SAE 4-Bolt
ER-150	1 1/2" SAE 4-Bolt
ER-200	2" SAE 4-Bolt
ER-250	2 1/2" SAE 4-Bolt

**Specifications
for DVP16 Series**

Description Dry Valve Pumps
Flow Range To 20 GPM (75.7 LTR) @ 1200 RPM
Displacements To 3.902 C.I.R. (63.94 CC's/REV.)
Maximum Pressure to 3000 PSI (207 BAR)
Maximum Speed to 3600 RPM
Rotation A or C
Bearings Journal
Construction Aluminum and Cast Iron

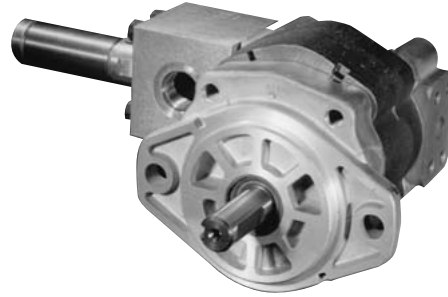

Performance Data

Pump Model	Section Size	Displacement/Revolution (Theoretical)					Maximum Pressure		Maximum Speed
		US Gallons	Cubic Inches	Liters	Cubic Centimeters	Imperial Gallons	PSI	BAR	RPM
DVP16	45	.0038	.878	.0144	14.388	.003	3000	207	3600
DVP16	65	.0055	1.270	.0208	20.812	.005	3000	207	3600
DVP16	85	.0072	1.663	.0273	26.760	.006	3000	207	3400
DVP16	100	.0085	1.964	.0321	32.184	.007	3000	207	3300
DVP16	115	.0097	2.241	.0367	36.723	.008	3000	207	3100
DVP16	150	.0127	2.934	.0481	48.080	.011	3000	207	2800
DVP16	180	.0152	3.511	.0575	57.535	.013	2200	152	2500
DVP16	200	.0169	3.902	.0639	63.942	.014	2000	138	2200

All data based on SAE 10W oil at 150°F. Available with Viton® Seals.
Consult factory for application of tandem units. Maximum speed in dry mode is 3600 RPM.

CAUTION: "Inlet vacuum" should not exceed 5" Hg at normal operating speed and temperature. Operation of pumps in excess of 5" Hg requires factory approval.

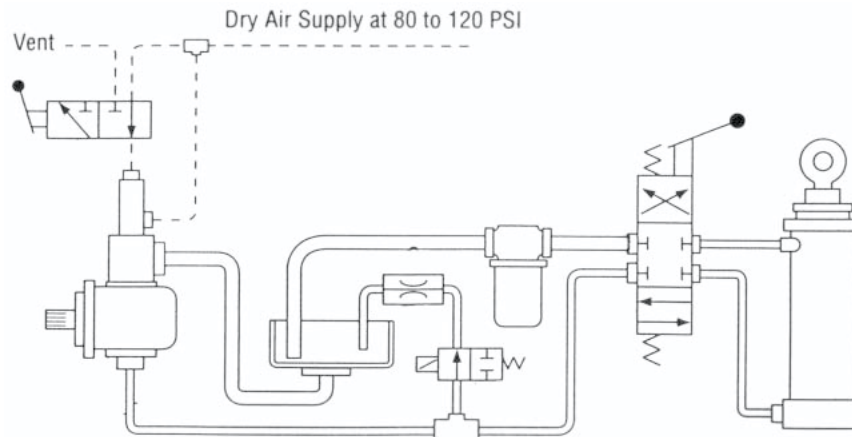

Typical Dry Valve System

PUMP SIZES	FLANGE TYPE									
	E, G & J		N		S & T		D		F	
	A	B	A	B	A	B	A	B	A	B
DVP16 45	118.3 (4.66)	144.0 (5.67)	88.1 (3.47)	113.7 (4.48)	132.5 (5.22)	158.2 (6.23)	89.9 (3.54)	115.5 (4.55)	92.9 (3.66)	118.6 (4.67)
DVP16 65	123.9 (4.88)	149.6 (5.89)	93.7 (3.69)	119.3 (4.70)	138.1 (5.44)	163.8 (6.45)	95.2 (3.75)	121.1 (4.77)	98.5 (3.88)	124.2 (4.89)
DVP16 85	129.2 (5.09)	154.9 (6.10)	99.0 (3.90)	124.7 (4.91)	143.5 (5.65)	169.1 (6.66)	100.8 (3.97)	126.4 (4.98)	103.8 (4.09)	129.5 (5.10)
DVP16 100	133.3 (5.25)	159.0 (6.26)	103.1 (4.06)	128.7 (5.07)	147.5 (5.81)	173.2 (6.82)	104.9 (4.13)	130.5 (5.14)	107.9 (4.25)	133.6 (5.26)
DVP16 115	137.4 (5.41)	163.0 (6.42)	107.1 (4.22)	132.8 (5.23)	151.6 (5.97)	177.2 (6.98)	108.9 (4.29)	134.6 (5.30)	112.0 (4.41)	137.6 (5.42)
DVP16 150	146.8 (5.78)	172.4 (6.79)	116.5 (4.59)	142.2 (5.60)	161.0 (6.34)	186.6 (7.35)	118.3 (4.66)	144.0 (5.67)	121.4 (4.78)	147.0 (5.79)
DVP16 180	154.9 (6.10)	180.5 (7.11)	124.7 (4.91)	150.3 (5.92)	169.1 (6.66)	194.8 (7.67)	126.4 (4.98)	152.1 (5.99)	129.5 (5.10)	155.1 (6.11)
DVP16 200	160.2 (6.31)	185.9 (7.32)	130.0 (5.12)	155.7 (6.13)	174.4 (6.87)	200.1 (7.88)	131.8 (5.19)	157.4 (6.20)	134.8 (5.31)	160.5 (6.32)

Note: See P 16 Curves for Performance Data.

C DIMENSIONS		
FLANGE TYPE	MM	IN
D	6.3	(.250)
E	4.7	(.187)
F	—	—
G	6.3	(.250)
J	6.3	(.250)
N	9.5	(.375)
S	5.8	(.200)
T	5.8	(.200)

SAE 4-Bolt NPT Connectors are available.
 See Accessory Section

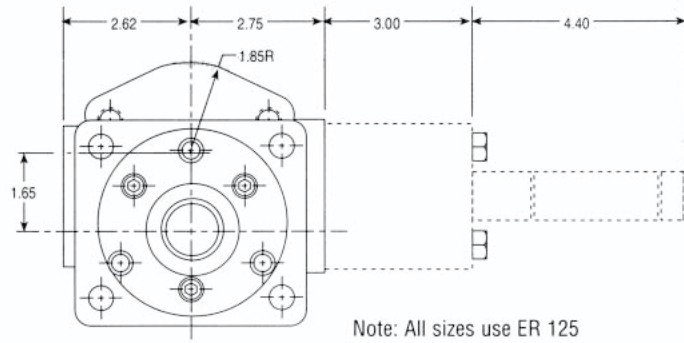
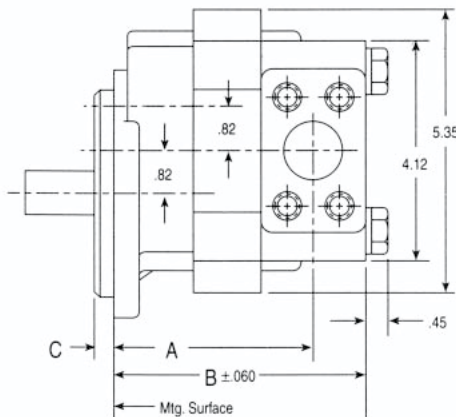

Inch equivalents for millimeter dimensions are shown in (**).

**Specifications
for DV20 Series**

Description Dry Valve Pumps
Flow Range To 47 GPM (177.9 LTR) @ 1200 RPM
Displacements To 9.101 C.I.R. (149.13 CC's/REV.)
Maximum Pressure to 2500 PSI (172 BAR)
Maximum Speed to 2500 RPM
Rotation A or C
Bearings Journal
Construction Aluminum

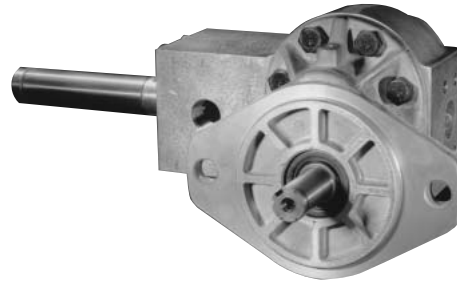

Performance Data

Pump Model	Section Size	Displacement/Revolution (Theoretical)					Maximum Pressure		Maximum Speed
		US Gallons	Cubic Inches	Liters	Cubic Centimeters	Imperial Gallons	PSI	BAR	RPM
DV20	150	.0131	3.026	.0496	49.587	.011	2500	172	2500
DV20	200	.0175	4.043	.0662	66.253	.015	2500	172	2500
DV20	250	.0219	5.059	.0829	82.902	.018	2500	172	2500
DV20	300	.0262	6.052	.0992	99.175	.022	2500(1)	172	2500
DV20	350	.0306	7.069	.1158	115.840	.025	2500(2)	172	2500
DV20	400	.0350	8.085	.1325	132.490	.029	2500	172	2500
DV20	450	.0394	9.101	.1491	149.139	.033	2500	172	2500

Notes: (1) 2100 PSI maximum due to torque limitations of No. 4 shaft. (2) 1800 PSI maximum due to torque limitations of No. 4 shaft.

All data based on SAE 10W oil at 150°F. Available with Viton® Seals.

*Case iron is not available on all models. Consult factory for availability. Consult factory for application of tandem units.



CAUTION: "Inlet vacuum" should not exceed 5" Hg at normal operating speed and temperature. Operation of pumps in excess of 5" Hg requires factory approval.

Mounting Dimensions

Pump Sizes	Dry Valve	A	B	C	D	E	F
DV20150	ER-125	167.9 (6.61)	111.8 (4.40)	76.2 (3.00)	133.4 (5.25)	N/A -	321.3 (12.65)
DV20200	ER-125	167.9 (6.61)	111.8 (4.40)	76.2 (3.00)	133.4 (5.25)	N/A N/A	321.3 (12.65)
DV20250	ER-150	167.9 (6.61)	111.8 (4.40)	76.2 (3.00)	133.4 (5.25)	58.8 (2.00)	372.1 (14.65)
DV20300	ER-150	175.3 (6.90)	111.8 (4.40)	76.2 (3.00)	133.4 (5.25)	58.8 (2.00)	372.1 (14.65)
DV20350	ER-150	182.4 (7.18)	111.8 (4.40)	76.2 (3.00)	133.4 (5.25)	58.8 (2.00)	372.1 (14.65)
DV20400	ER-200	189.7 (7.47)	157.7 (6.21)	101.6 (4.00)	133.4 (5.25)	58.8 (2.00)	443.5 (17.46)
DV20450	ER-200	196.9 (7.75)	157.7 (6.21)	101.6 (4.00)	133.4 (5.25)	58.8 (2.00)	443.5 (17.46)

Inch equivalents for millimeter dimensions are shown in (**).

Pump Size	SAE 4-Bolt Connector Ports			
	Inlet		Outlet	
	Conn. Sz.	Hole Dia.	Conn. Sz.	Hole Dia.
150	1-1/4"	30.2 (1.19)	1"	23.8 (.937)
200	1-1/4"	30.2 (1.19)	1"	23.8 (.937)
250	1-1/2"	38.1 (1.50)	1-1/4"	30.2 (1.19)
300	1-1/2"	38.1 (1.50)	1-1/4"	30.2 (1.19)
350	1-1/2"	38.1 (1.50)	1-1/4"	30.2 (1.19)
400	2"	50.8 (2.00)	1-1/4"	34.8 (1.37)
450	2"	50.8 (2.00)	1-1/4"	34.8 (1.37)

Size	G	H	J	K	L
1"	12.9 (.51)	26.2 (1.031)	26.2 (1.03)	57.4 (2.062)	3/8-16NC
1-1/4"	15.0 (.59)	30.2 (1.188)	29.2 (1.15)	58.8 (2.313)	7/16-14NC
1-1/2"	17.8 (.70)	35.7 (1.406)	34.8 (1.37)	69.8 (2.750)	1/2-13NC
2"	21.3 (.84)	42.9 (1.688)	38.9 (1.53)	77.8 (3.062)	1/2-13NC

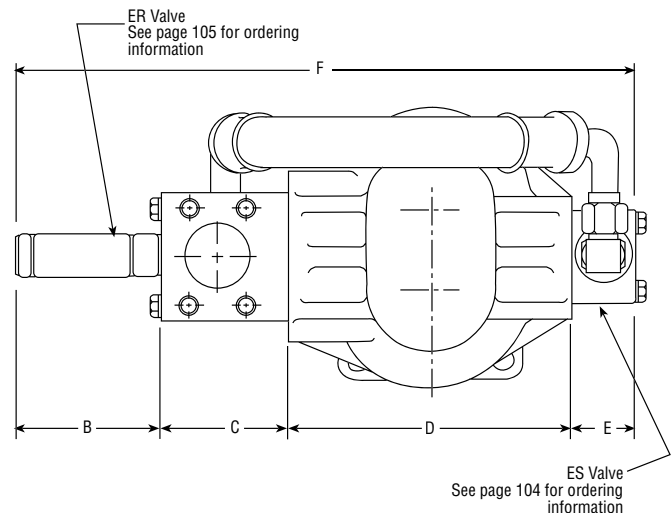
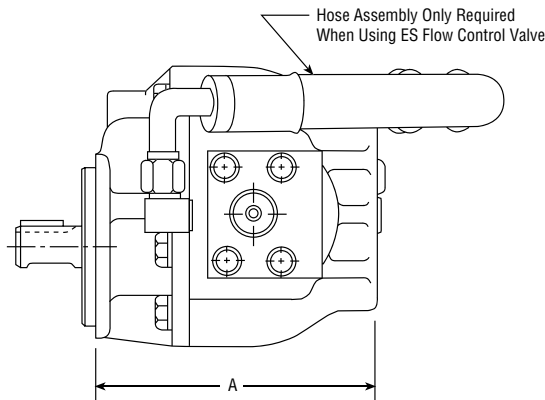
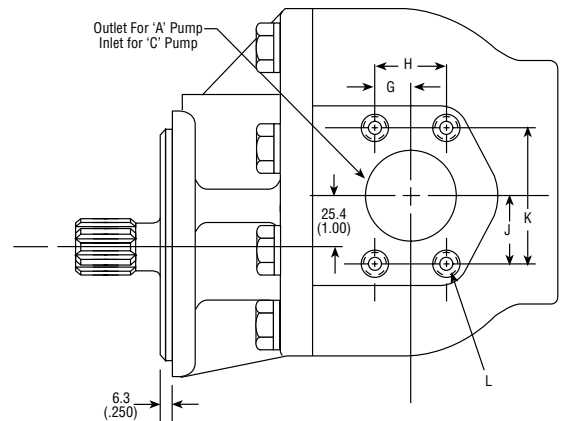

SAE 4-Bolt NPT Connectors are available.
 See Accessory Section

**Specifications
for DV25 Series**

Description Dry Valve Pumps
Flow Range To 99 GPM (374.7 LTR) @ 1200 RPM
Displacements To 19.22 C.I.R. (314.96 CC's/REV.)
Maximum Pressure to 3000 PSI (207 BAR)
Maximum Speed to 2500 RPM
Rotation A or C
Bearings Journal
Construction Aluminum

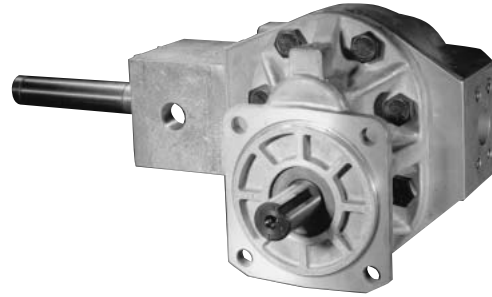

Performance Data

Pump Model	Section Size	Displacement/Revolution (Theoretical)					Maximum Pressure		Maximum Speed
		US Gallons	Cubic Inches	Liters	Cubic Centimeters	Imperial Gallons	PSI	BAR	RPM
DV25	300	.0262	6.05	.0992	99.142	.022	3000	207	2500
DV25	350	.0306	7.07	.1158	115.857	.026	3000	207	2500
DV25	400	.0350	8.08	.1324	132.408	.029	3000	207	2500
DV25	450	.0394	9.10	.1491	149.123	.033	3000	207	2500
DV25	500	.0435	10.05	.1647	164.690	.036	2500	172	2500
DV25	550	.0479	11.06	.1812	181.241	.040	2500	172	2500
DV25	660	.0581	13.42	.2200	219.915	.048	2500*	172	2500
DV25	770	.0671	15.50	.2540	254.000	.056	2500*	172	2500
DV25	950	.0832	19.22	.3150	314.960	.069	2500*	172	2500

Available with Viton® seals.
Consult factory for application of tandem units. *Consult factory for application approval.



CAUTION: "Inlet vacuum" should not exceed 5" Hg at normal operating speed and temperature. Operation of pumps in excess of 5" Hg requires factory approval.

MOUNTING DIMENSIONS							
Pump Model	Dry Valve	A	B	C	D	E	F
DV25300	ER-200	223.7 (8.81)	157.7 (6.21)	101.6 (4.00)	222.2 (8.75)	50.8 (2.00)	532.3 (20.96)
DV25350	ER-200	223.7 (8.81)	157.7 (6.21)	101.6 (4.00)	222.2 (8.75)	50.8 (2.00)	532.3 (20.96)
DV25400	ER-200	223.7 (8.81)	157.7 (6.21)	101.6 (4.00)	222.2 (8.75)	50.8 (2.00)	532.3 (20.96)
DV25450	ER-200	223.7 (8.81)	157.7 (6.21)	101.6 (4.00)	222.2 (8.75)	50.8 (2.00)	532.3 (20.96)
DV25500	ER-250	8.63 (219.2)	157.7 (6.21)	101.6 (4.00)	222.2 (8.75)	82.5 (3.25**)	564.1 (22.21)
DV25550	ER-250	223.7 (8.81)	157.7 (6.21)	101.6 (4.00)	222.2 (8.75)	82.5 (3.25**)	564.1 (22.21)
DV25660	ER-250	230.1 (9.06)	157.7 (6.21)	101.6 (4.00)	222.2 (8.75)	82.5 (3.25**)	564.1 (22.21)
DV25770	ER-250	236.4 (9.31)	157.7 (6.21)	101.6 (4.00)	222.2 (8.75)	82.5 (3.25**)	564.1 (22.21)
DV25950	ER-250	252.7 (9.95)	157.7 (6.21)	146.0 (5.75*)	222.2 (8.75)	82.5 (3.25)	608.5 (23.96)

*Includes 1.75" for Adapter Kit 1677
 **Includes 1.25" for Adapter Kit 14190

Pump Model	PORTS			
	SAE 4-Bolt Conn.		Conn. Hole Dia.	
	Suction	Discharge	Suction	Discharge
DV25300	2"	1-1/4"	50.8 (2.00)	31.7 (1.25)
DV25350	2"	1-1/4"	50.8 (2.00)	31.7 (1.25)
DV25400	2"	1-1/4"	50.8 (2.00)	31.7 (1.25)
DV25450	2"	1-1/4"	50.8 (2.00)	31.7 (1.25)
DV25500	2-1/2"	1-1/2" ⁽²⁾	63.5 (2.50)	38.1 (1.50)
DV25550	2-1/2"	1-1/2" ⁽²⁾	63.5 (2.50)	38.1 (1.50)
DV25660	2-1/2"	1-1/2" ⁽²⁾	63.5 (2.50)	38.1 (1.50)
DV25770	2-1/2"	1-1/2" ⁽²⁾	63.5 (2.50)	38.1 (1.50)
DV25950	3" ⁽¹⁾	2"	76.2 (3.00)	50.8 (2.00)

(1)Requires Port Adapter Kit 16771 to mount ER250 valve
 (2)Requires Port Adapter Kit 14190 to mount ES valve

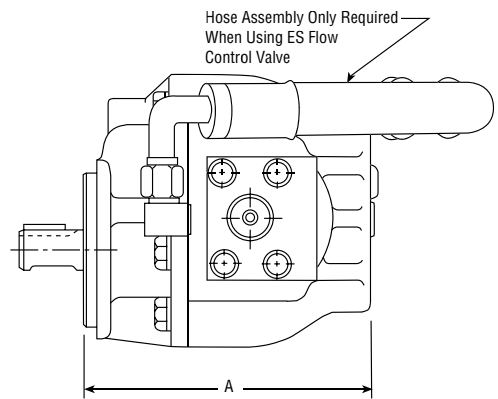

Inch equivalents for millimeter dimensions are shown in (**).

SAE 4-Bolt Connector Ports					
Size	G	H	J	K	L
1-1/4"	15.0 (.59)	30.2 (1.188)	29.2 (1.15)	58.7 (2.313)	7/16-14NC
1-1/2"	17.8 (.70)	35.7 (1.406)	34.8 (1.37)	69.8 (2.750)	1/2-13NC
2"	21.3 (.84)	42.9 (1.688)	38.9 (1.53)	77.8 (3.062)	1/2-13NC
2-1/2"	25.4 (1.00)	50.8 (2.000)	44.4 (1.75)	88.9 (3.500)	1/2-13NC
3"	30.7 (1.21)	61.9 (2.438)	53.1 (2.09)	106.4 (4.188)	5/8-11NC

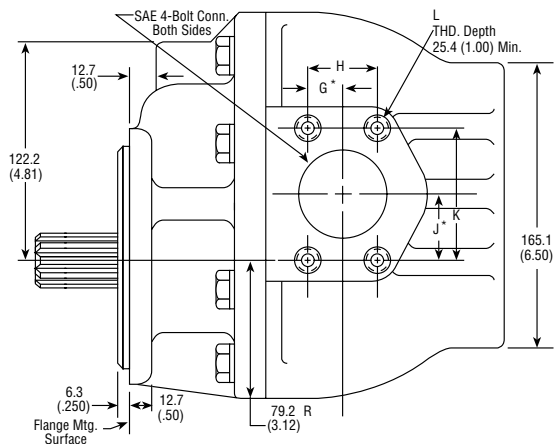
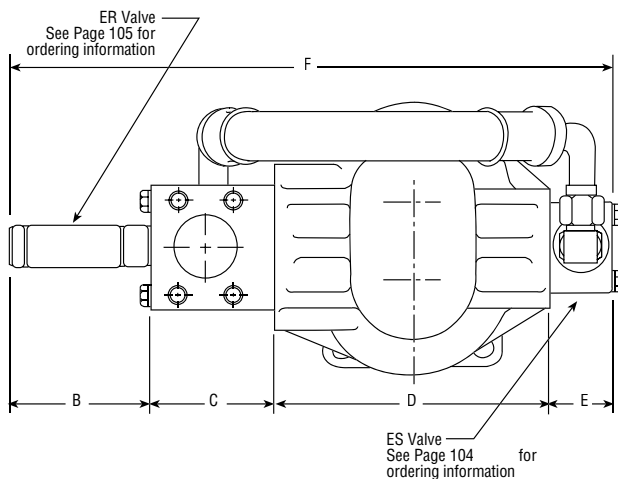

Shafts Available for DV16 Pump Series

Inch equivalents for millimeter dimensions are shown in (**).

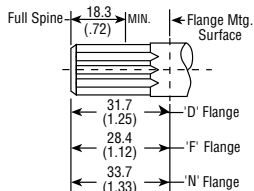
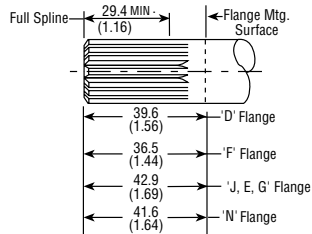
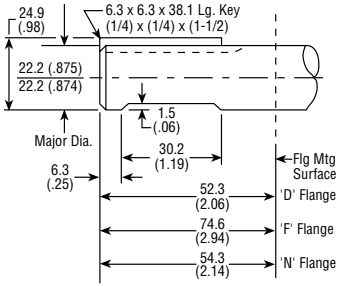
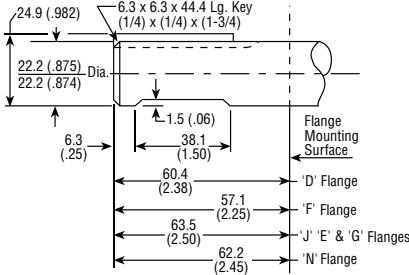
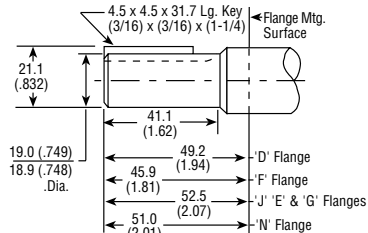
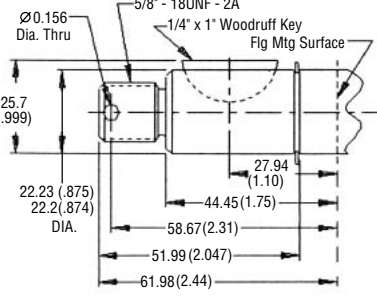
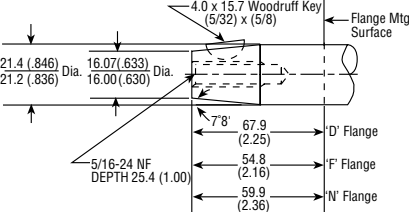
<p>1 5/8" Dia. 9 Tooth Spline Flat Root Side Fit Torque Limit 52 Lbs. Ft. (70.5 Nm) Available with 'D' 'F' & 'N' Flanges and in sizes P16-45 thru P16-100 only</p>  <p>Spline Data Diametral Pitch 16/32 Pressure Angle 30° No. Of Teeth 9</p>	<p>2 7/8" Dia. 13 Tooth Spline Flat Root Side Fit Torque Limit 184 Lbs. Ft. (249.4 Nm) Available in all sizes and flanges.</p>  <p>Spline Data Diametral Pitch 16/32 Pressure Angle 30° No. Of Teeth 13</p>	<p>3 7/8" Straight Shaft Torque Limit 184 Lbs. Ft. (249.4 Nm) Available in all sizes and D, F and N Flanges Only</p> 
<p>5 7/8" Straight Shaft Torque Limit 184 Lbs. Ft. (249.4 Nm) Available in all sizes and flanges.</p> 	<p>6 3/4" Straight Shaft Torque Limit 105 Lbs. Ft. (142.3 Nm) Available in sizes P16-45 thru P16-115 only and all flanges</p> 	<p>8 7/8" Straight Shaft Torque Limit 184 Lbs. Ft. (249.4 Nm) Available with N flange and sizes P16-65, P16-85 and P16-100 only.</p> 
<p>9 7/8" Tapered Shaft Torque Limit 184 Lbs. Ft. (249.4 Nm) Available in all sizes and D, F and N flanges only</p> 		

Shafts Available for DV20 Pump Series

Inch equivalents for millimeter dimensions are shown in (**).

<p>1 SAE 'C' 1-1/4" 14-Tooth Spline Flat Root Side Fit Torque limit 655 Lbs. Ft. (888. Nm) Available in all sizes.</p> <p>"Single" Pumps only</p> <p>"Tandem" Pumps only</p> <p>Spline Data Diametral Pitch 12/24 Pressure Angle 30° No. Of Teeth 14</p>	<p>2 1" Dia. Straight Shaft Torque limit 341 Lbs. Ft. (462.3 Nm)</p> <p>CAUTION: Due to shaft torque limitations, consult the Factory for approval before applying this shaft in models of -350 size and larger pumps. Not available for tandem pumps.</p>	<p>3 SAE 'C' 1-1/4" 14 Straight Shaft Torque limit 655 Lbs. Ft. (888. Nm) Available on all sizes.</p>
<p>4 7/8" Dia. 13 Tooth Spline Flat Root Side Fit Torque limit 184 Lbs. Ft. (249.4 Nm)</p> <p>CAUTION: Due to shaft torque limitations, consult the Factory for approval before applying this shaft in models of -350 size and larger pumps. Not available for tandem pumps.</p> <p>Spline Data Diametral Pitch 16/32 Pressure Angle 30° No. Of Teeth 13</p>	<p>5 1-1/4" Straight Shaft Torque limit 655 Lbs. Ft. (888. Nm) Available on all sizes</p>	

Shafts Available for DV25 Series

<p>1 SAE 'C' 1-1/4" 14 Tooth Spline Flat Root Side Fit Torque limit 655 Lbs. Ft. (888.0 Nm) Available for all single section sizes and PB25 sizes 350 to 660 only</p> <p>Spline Data Diametral Pitch 12/24 Pressure Angle 30° No. Of Teeth 14</p>	<p>2 SAE 'C' 1-1/4" Straight Shaft Torque limit 655 Lbs. Ft. (888.0 Nm) Available for all single section sizes only</p>	<p>5 1-1/4" Straight Shaft Torque limit 655 Lbs. Ft. (888.0 Nm) Available for all single section sizes only</p>
---	---	---

Mounting Flanges Available for DV16 Pump Series

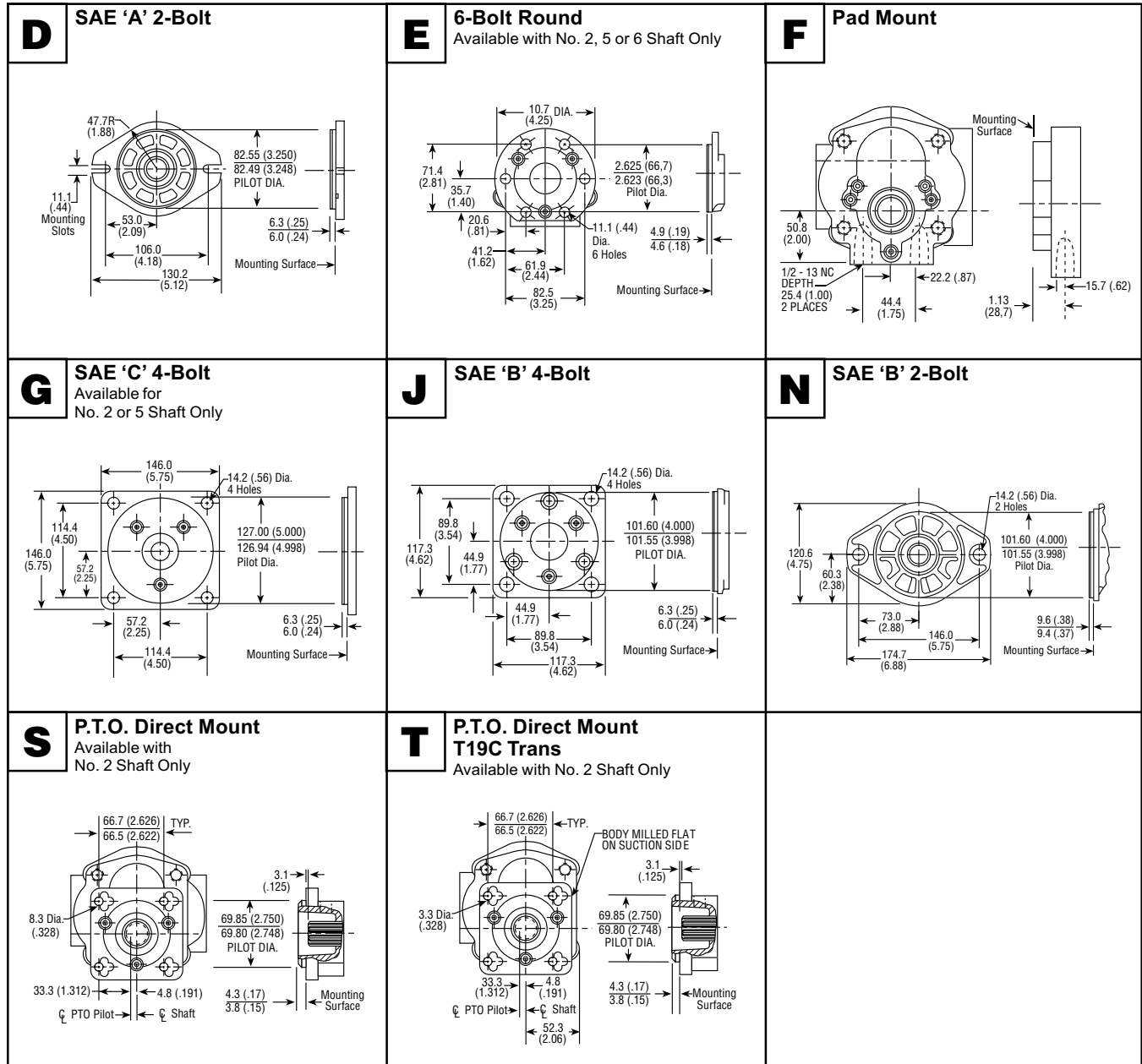

Inch equivalents for millimeter dimensions are shown in (**).

Mounting Flanges Available for DV20 Series

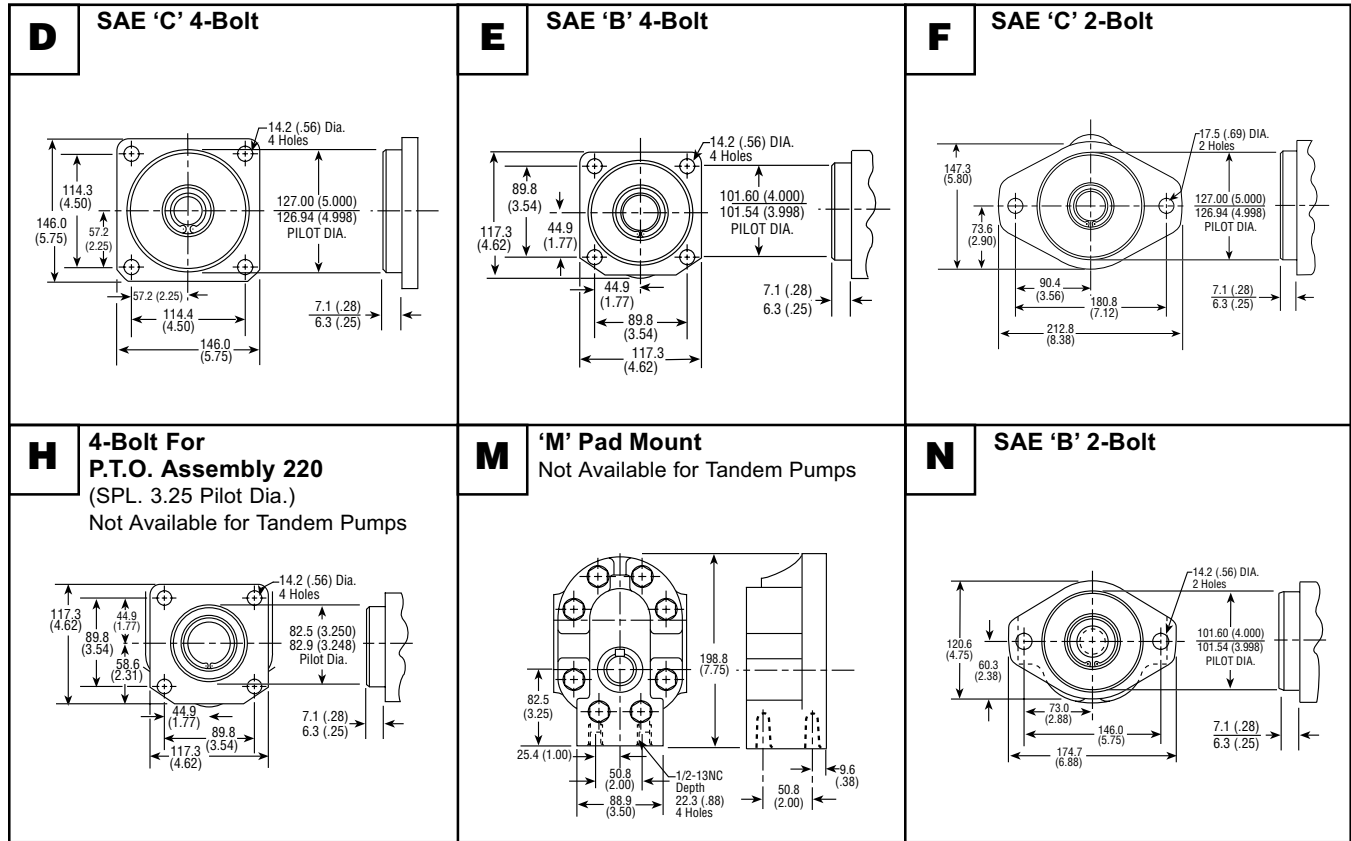

Mounting Flanges Available for DV25 Series

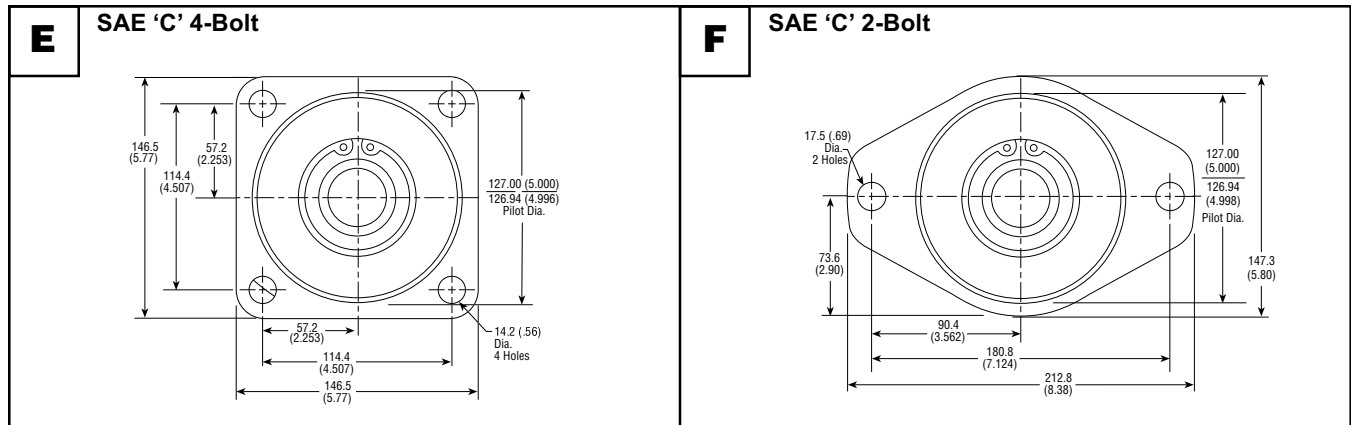

Inch equivalents for millimeter dimensions are shown in (**).

**Specifications
 for ES Flow Control**

Body Material: Cast Grey Iron

Valve Weight: 3.5 lbs. (1.31 Kg.)

Working Pressure: 2500 PSI (172 Bar)

Standard Orifice Sizes Available: 5/16 7.9 (.312)
 3/8 9.5 (.375)
 7/16 11.1 (.438)
 1/2 12.7 (.500)
 9/16 14.2 (.562)

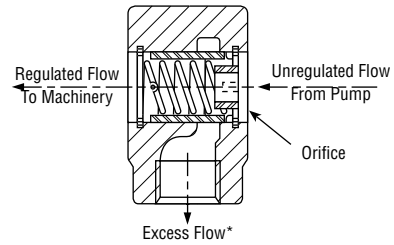

As unregulated flow enters the "ES" valve from the pump, the pressure drop across the orifice creates a force that works against the restraining spring. If the flow is enough to generate a force that exceeds the spring force, the excess flow* is allowed to escape through the "excess flow" port.

* The excess flow cannot be used for a secondary circuit. It must be returned to the tank.

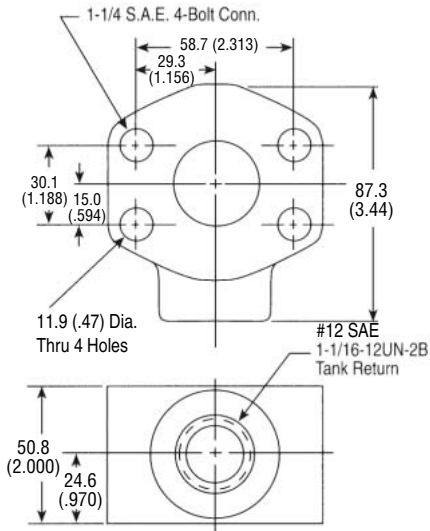
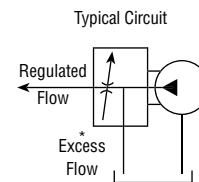

Standard Flow Valve Available	
Model	Orifice Size
ER-312	7.92 (.312)
ER-375	9.52 (.375)
ER-437	11.10 (.437)
ER-500	12.7 (.500)
ER-562	14.27 (.562)

Inch equivalents for millimeter dimensions are shown in (**).

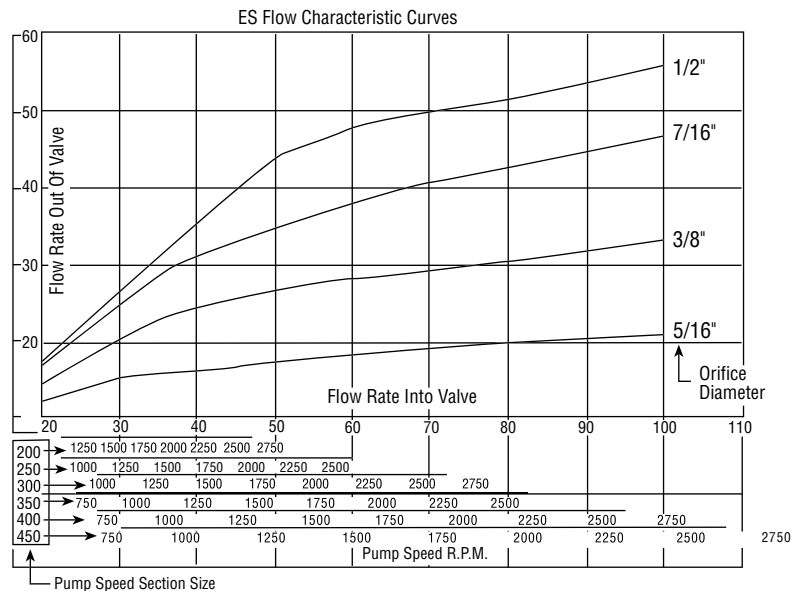

Valve Size	A	B	C	D	E	F	G	H	J
ER-125	79.2 (3.12)	76.2 (3.00)	44.4 (1.75)	39.6 (1.56)	38.1 (1.50)	76.2 (3.00)	57.7 (2.313)	29.2 (1.15)	30.1 (1.188)
ER-150	101.6 (4.00)	91.9 (3.62)	50.8 (2.00)	50.8 (2.00)	38.1 (1.50)	76.2 (3.00)	69.8 (2.750)	34.7 (1.37)	35.7 (1.406)
ER-200	114.3 (4.50)	101.6 (4.00)	53.8 (2.12)	57.1 (2.25)	57.1 (2.25)	101.6 (4.00)	77.7 (3.062)	38.8 (1.53)	42.8 (1.688)
ER-250	114.3 (4.50)	101.6 (4.00)	57.1 (2.25)	57.1 (2.25)	53.8 (2.12)	101.6 (4.00)	88.9 (3.500)	44.4 (1.75)	50.8 (2.000)

Valve Size	K	L	M	N	O	P	Q	T	S	T
ER-125	14.9 (.59)	30.1 (1.188)	14.9 (.59)	58.7 (2.313)	29.2 (1.15)	7/16-14	12.7 (1/2)	187.9 (7.40)	—	#12 SAE
ER-150	17.3 (.70)	35.7 (1.406)	17.7 (.70)	69.8 (2.750)	34.7 (1.37)	1/2-13	14.2 (9/16)	187.9 (7.40)	—	#12 SAE
ER-200	21.3 (.84)	42.8 (1.688)	21.3 (.84)	77.7 (3.062)	38.8 (1.53)	1/2-13	14.2 (9/16)	259.3 (10.21)	—	3/4 NPT
ER-260	25.4 (1.00)	50.8 (2.000)	25.4 (1.00)	88.9 (3.500)	44.4 (1.75)	1/2-13	14.2 (9/16)	259.3 (10.21)	3/4 NPT	—

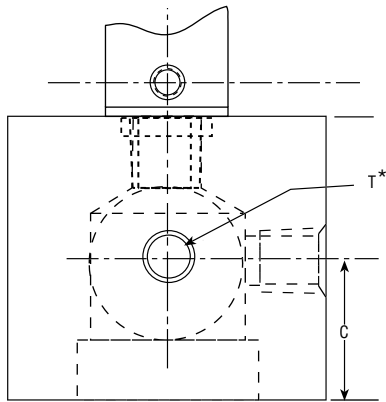

Please Note:
 To order with pump, order as part of pum model number.
 See HOW TO ORDER section of this catalog.

Inch equivalents for millimeter dimensions are shown in (**).

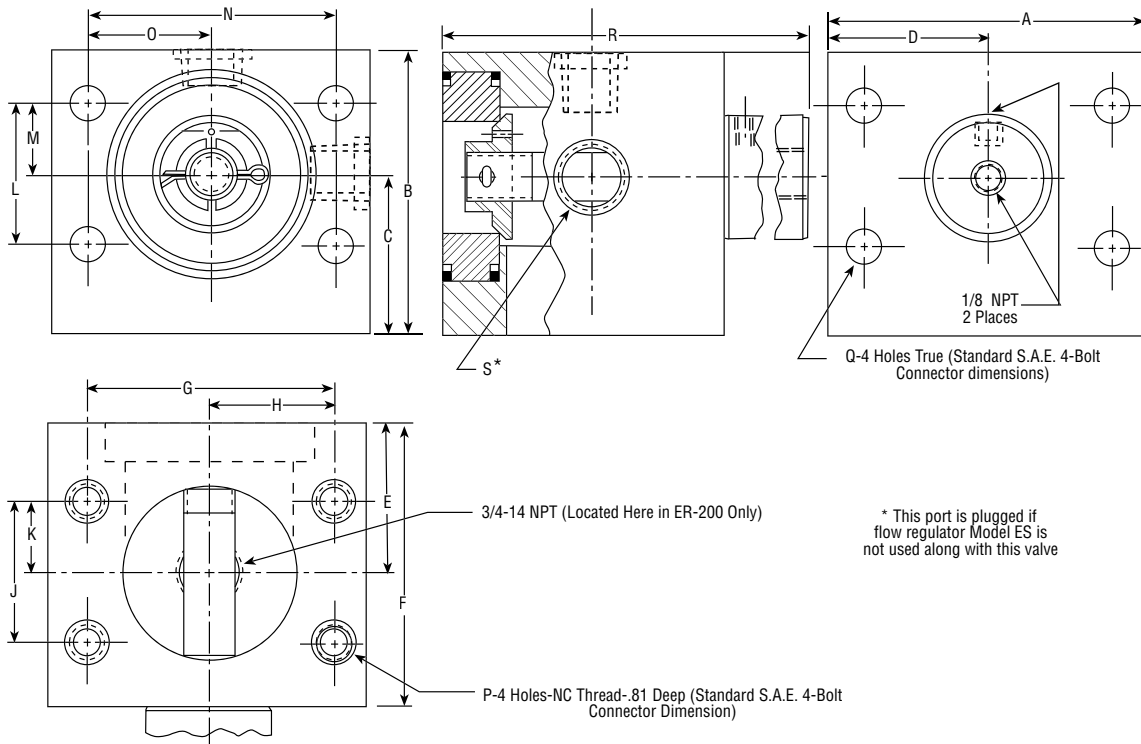

* This port is plugged if flow regulator Model ES is not used along with this valve

**General Information
 for Wet Pump**

- New patented standby mode eliminates the need for dry valves or clutches
- Low standby pressure
- Cast iron construction
- 10 tooth gears for low noise
- Large diameter journal bearings for long life
- New pressure balance design
- Controls: Manual, Solenoid, Electronic and Overspeed
- Especially suited for front loader refuse trucks



■ Built-In Benefits:

- **New Patented Standby Mode Eliminates Dry Valves or Clutches:**
 The new "stand-by" mode is provided by an air actuated integral system.
- **No External Bleed Valves or Associated Hardware Needed:**
 There is no wasted pump flow in the pumping mode.
- **Very Low Standby Pressure:**
 The power requirements are lower than most dry valve systems (50 PSI or less).
- **Rugged Cast Iron Body:**
 Exceptional resistance to pressure spikes and contamination for long life.
- **10 Tooth Gear Design:**
 Provides high efficiency and contamination resistance for demanding applications.
- **Pressures to 3500 PSI:**
 Flexibility for almost any application.
- **Large Diameter Journal:**
 Large shafts and journal bearings allow high pressure use with a long life.
- **New Pressure Balanced Design:**
 One piece pressure balance design simplifies assembly and service.
- **Light Weight:**
 This creative new design is more compact, has fewer parts, and is lighter than comparable pumps.
- **Eliminates Need for Large Flow Capacity By-Pass Line to Reservoir**

Operation

The new "stand-by" mode of the Model FPW257 allows you to direct-mount the pump without clutches, dry valves or PTOs. This by-pass feature has low power requirements in the standby mode and eliminates the need for external bleed valves.

Stand-By Mode

In the standby mode, the integral air shifted valve allows the pump flow to be by-passed to the inlet side of the pump. This is done with very little pressure loss, therefore the power demand is very low. At the same time, some of the flow is routed through the journal bearing area to lubricate and cool the bearings.

Because all flow is internal to the pump, there is no need to provide an external bleed valve. The only requirement is for a bearing drain line direct to the reservoir.

Pumping Mode

In the pumping mode, the valve blocks the internal coring so that full pump flow is available for work.

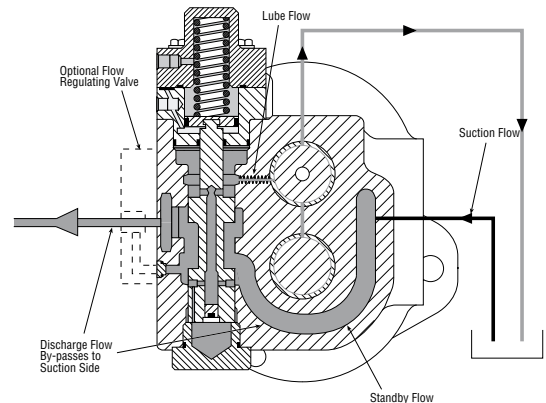

Stand-By Mode

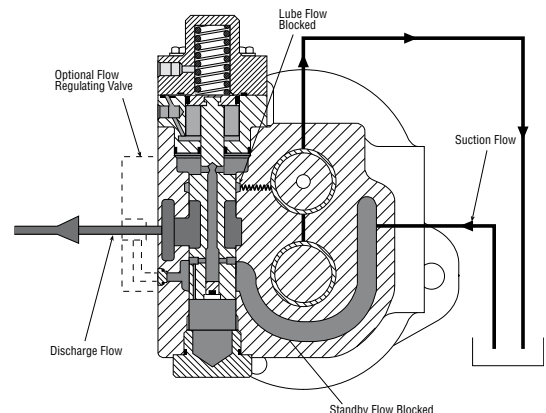

Pumping Mode

How to Order Wet Pump:

Select the desired symbol (in the correct position) to construct a model code.

Assembly Example:

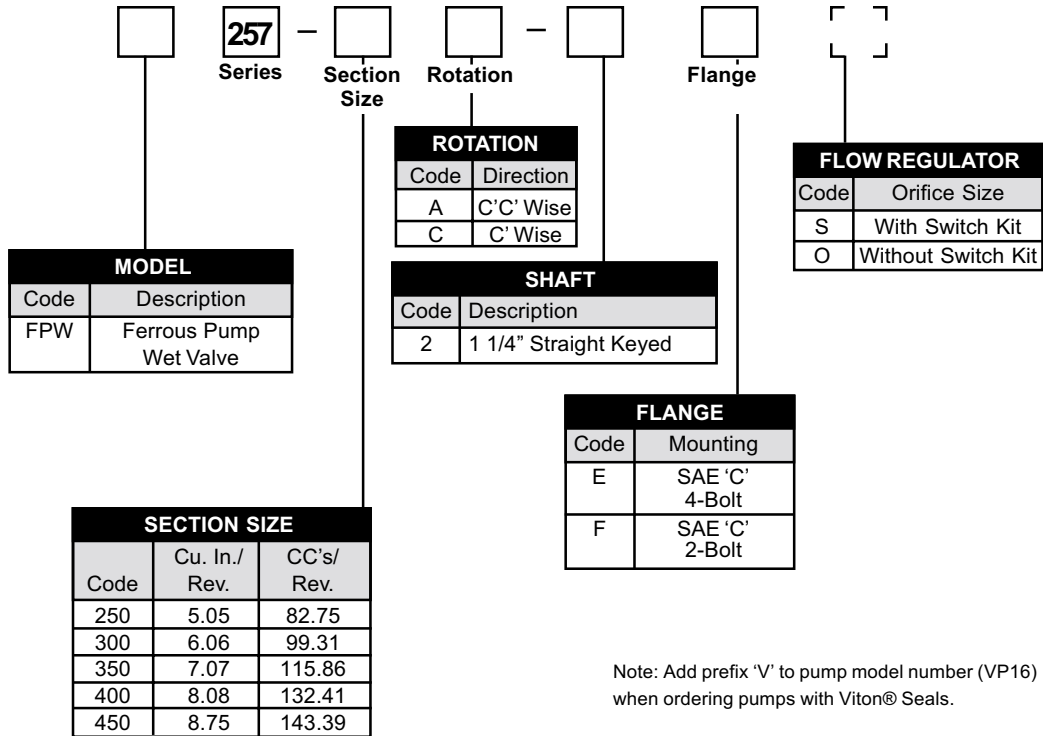

Note: Add prefix 'V' to pump model number (VP16) when ordering pumps with Viton® Seals.

**Specifications
for FPW257 Series**

Description Wet Valve Pump
Flow Range To 94.4 GPM (357.3 LTR)
Displacements To 8.750 C.I.R. (143 cc's/Rev.)
Maximum Pressure to 3500 PSI
Maximum Speed to 2500 RPM
Rotation A or C
Bearings Journal
Construction Cast Iron



Performance Data

Pump Model	Section Size	Displacement/Revolution (Theoretical)					Maximum Pressure		Maximum Speed
		US Gallons	Cubic Inches	Liters	Cubic Centimeters	Imperial Gallons	PSI	BAR	RPM
FPW257	250	.0219	5.050	.0828	82.75	.0282	3500	246	2500
FPW257	300	.0262	6.060	.0993	99.31	.0219	3500	246	2500
FPW257	350	.0306	7.070	.1159	115.86	.0255	3500	246	2500
FPW257	400	.0350	8.080	.1324	132.41	.0291	3200	220	2500
FPW257	450	.0379	8.750	.1434	143.39	.0316	3000	207	2500

Available with Viton Seals.



CAUTION: "Inlet vacuum" should not exceed 5" Hg at normal operating speed and temperature. Operation of pumps in excess of 5" Hg requires factory approval.

Dimensional Data

MOUNTING DIMENSIONS							
Pump Model	A	B	C	D	E	F	G
-250	76.70 (3.02)	118.90 (4.68)	172.20 (6.78)	211.80 (8.34)	124.50 (4.90)	185.40 (7.30)	187.70 (7.39)
-300	82.30 (3.24)	124.50 (4.90)	177.80 (7.00)	217.40 (8.56)	130.00 (5.12)	191.00 (7.52)	193.30 (7.61)
-350	87.90 (3.46)	130.00 (5.12)	183.40 (7.22)	223.00 (8.78)	139.40 (5.49)	196.60 (7.74)	198.90 (7.83)
-400	92.50 (3.64)	134.60 (5.30)	188.00 (7.40)	227.60 (8.96)	141.00 (5.55)	201.20 (7.92)	203.50 (8.01)
-450	97.80 (3.85)	140.00 (5.51)	193.30 (7.61)	232.90 (9.17)	146.30 (5.76)	208.50 (8.13)	208.80 (8.22)

Dimensional Data

Inch equivalents for millimeter dimensions are shown in (**).

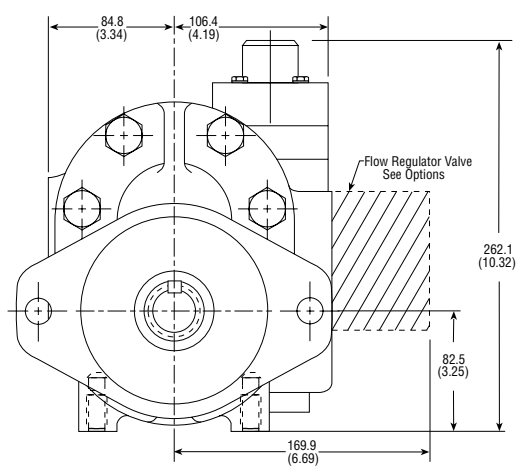
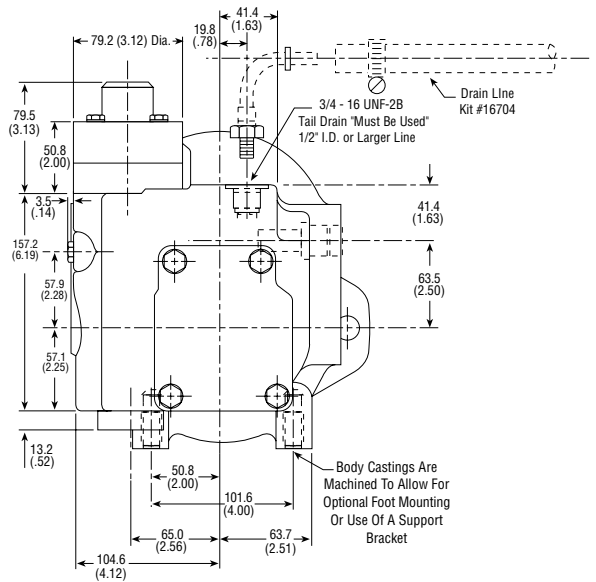
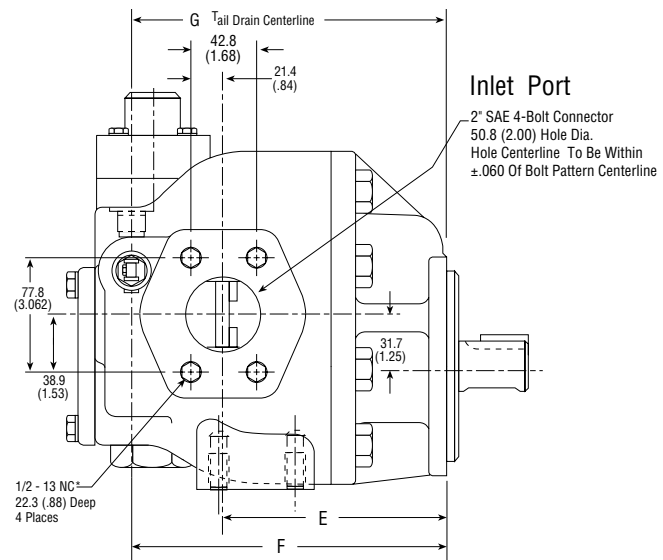
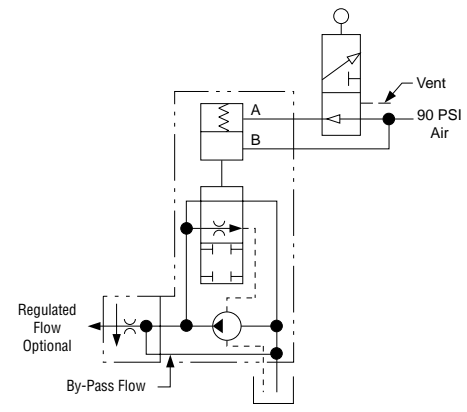
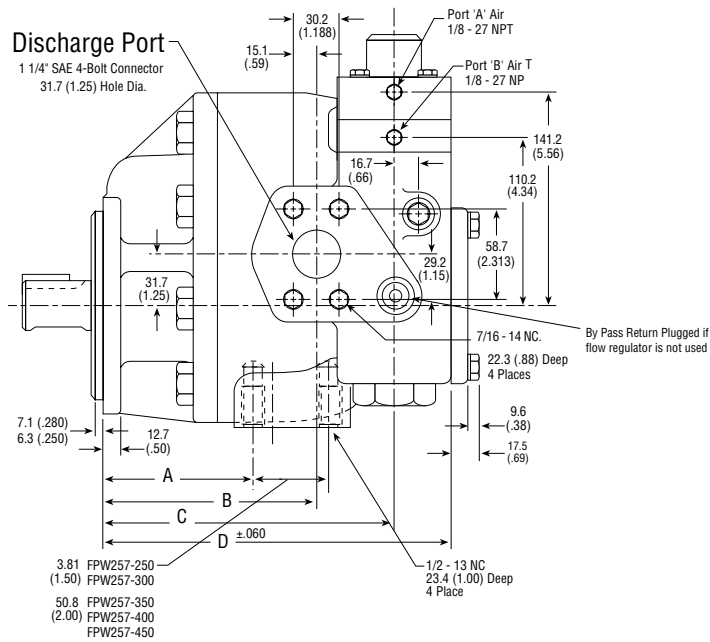

Shafts Available for Wet Pumps

Inch equivalents for millimeter dimensions are shown in (**).

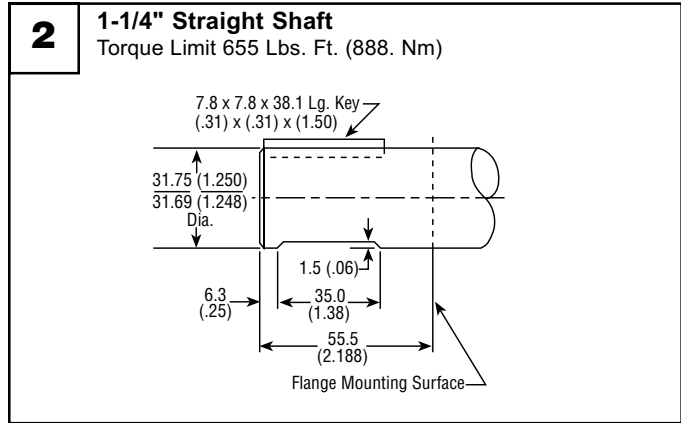

Mounting Flanges Available for Wet Pumps

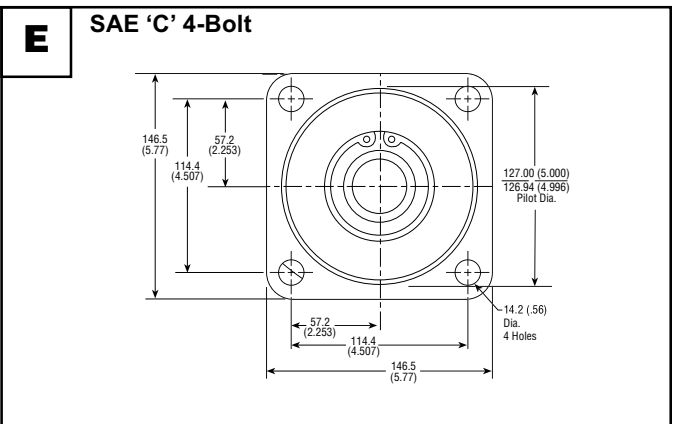
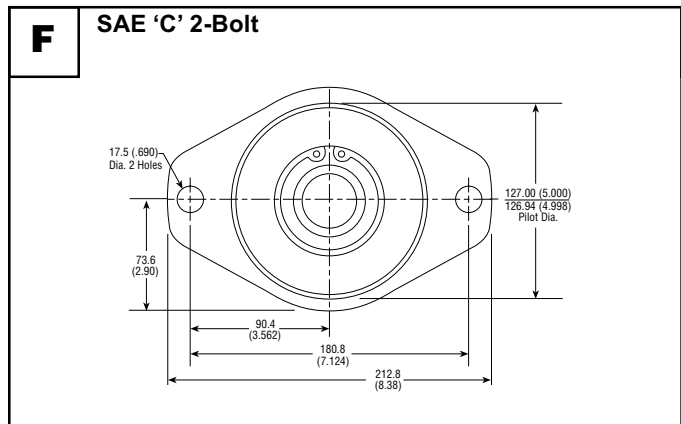



Flow Regulator Valve (FR) –Option

The by-pass flow regulator allows the excess flow above the regulated flow to be by-passed for return to pump suction. Typically, they are used for limiting flow to refuse packer circuits. The valve is designed to be bolted directly to the discharge port of the FPW257 Model pump with a 1-1/4" SAE 4-bolt connector pattern.

Note: The excess flow can not be used for secondary circuits.

Performance Data

Flow Characteristic Curves

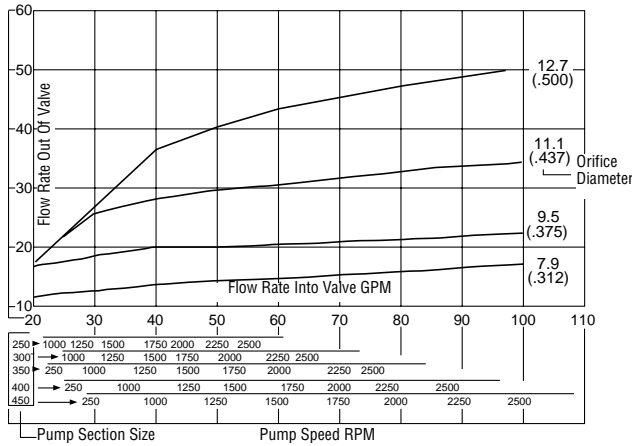

Standard Orifice Sizes Available:
 FR-31 — 7.92 (.312)
 FR-38 — 9.52 (.375)
 FR-44 — 11.13 (.438)
 FR-50 — 12.7 (.500)

See chart to determine correct size.

Please Note:
 To order with pump, order as part of pump model number.

See HOW TO ORDER section of this catalog.

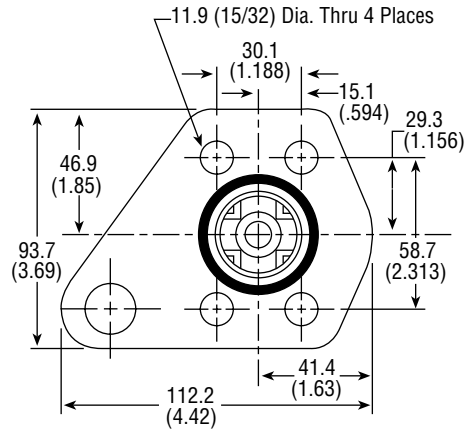
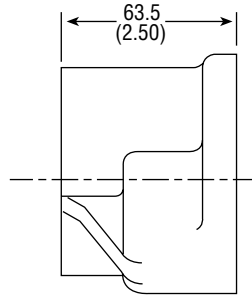
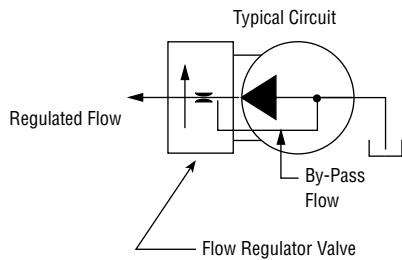

Inch equivalents for millimeter dimensions are shown in (**).

Accessories –With Manual Shift

The Manual Shift Package provides a convenient method of controlling the "WET" pump from the pumping mode to the standby mode. The pump control system utilizes a 70-140 PSI air source generally available from the vehicle. Along with the Manual Shift Valve, the "Control Panel" contains a RED light to indicate when the pump is in the "WET" (Standby) mode.

Note: It is strongly recommended that all installations include a "Pressure Protection Valve" to ensure the vehicle air pressure is maintained in case of a line or fitting failure in the pump control system.



COMPLETE Manual Shift Package contains:

- Manual Air Shift Package w/flow regulator
 - Manual Air Shift Valve Package
 - Pressure switch
 - Protection valve
 - Manual Valve Package
 - Indicator Package
 - Hose Package
 - Drain Line Kit
 - Pneumatic Tubing Kit
- (Contains enough fittings and tubing for normal installation.)

Accessories –With Solenoid Shift

The Solenoid Shift Package provides a convenient method of electrically controlling the "WET" pump from the pumping mode to the standby mode. The pump control system utilizes a 70-140 PSI air source generally available from the vehicle. Along with the Solenoid Control switch, the "Control Panel" contains a RED light to indicate when the pump is in the "WET" (Standby) mode.

Note: It is strongly recommended that all installations include a "Pressure Protection Valve" to ensure the vehicle air pressure is maintained in case of a line or fitting failure in the pump control system.



COMPLETE Solenoid Air Shift Package contains:

- Solenoid Air Shift Package w/flow regulator
 - Solenoid Air Shift Package
 - Pressure switch
 - Protection valve
 - Solenoid Shift Package
 - Indicator Package
 - Hose Package
 - Drain Line Kit
 - Pneumatic Tubing Kit
- (Contains enough fittings and tubing for normal installation.)

Accessories		
Item No.	Item Description	Part No.
A	COMPLETE Manual Air Shift Package (consists of items 3,5,6,7 & 8)	29884
B	COMPLETE Solenoid Air Shift Package (consists of items 4, 5, 6, 7 & 8)	29885
1	Manual Air Shift Package (Consisting of accessory items 3, 5 & 6)	17514
2	Solenoid Air Shift Package (Consisting of accessory items 4, 6, & 6)	17515
3	Manual Valve Package	17508
4	Solenoid Valve Package	17509
5	Indicator Package	17506
6	Hose Package	17507
7	Pressure Switch (Air)	16117
8	Protection Valve (Air)	16393

Air System Installation and Warning Notes:

- All air system additions or alterations must comply with Federal Standard FVMSS-121.
- Pressure protection valve P/N 16393 is provided to protect existing air brake systems. It maintains reserve air system hold back pressure of 65-75 PSI.
- Ports on the pressure protection valve are 1/4-18 NPTF (Female). Be sure to note proper air flow direction arrow on valve body for installation.
- Install pressure protection valve, P/N 16393 by making a tee connection to the main air line. **DO NOT** use the valve as a through port that supplies air to the original air system.
- The inlet port to the pressure protection valve P/N 16393 must be connected using approved brass or steel fittings. Nylon, other type plastics, non-approved (Ferrous and non-ferrous) fittings shall not be used.
- The secondary air system is the preferred connection point for auxiliary devices. The primary system should only be used if secondary system connections are impractical.
- Connect to supply lines at/or between service tanks and in-cab control valves only.
- DO NOT** connect lines between air tanks and relay valves.
- DO NOT** connect to lines between foot valve and relay valves or front axle delivery to brakes (delivery system).
- DO NOT** connect to spring brake lines or lines to emergency system spring brake valve.
- DO NOT** connect to supply (wet) tank or connecting lines.
- DO NOT** tap between check valve at supply line to air reservoir and reservoir port.

SAE 4-BOLT CONNECTORS						
Part Number	Kit NUMBER	Pipe Size	SAE Pad Size	*Capscrew Size 4 Required	†O-Ring Part No. (1) Req.'d	Connector No. (1) Req'd
0091000	13025 A	1/2"	1/2"	0086600 / 5/16-18NCX1-1/2" LG.	0082264	0089810
0091001	13025 B	3/4"	3/4"	0086630 / 3/8-16NCX1-1/2" LG.	0082304	0089820
0091002	13025 C	1"	1"	0086635 / 3/8-16NCX1-3/4" LG.	0082354	0089840
0091003	13025 D	1-1/4"	1-1/4"	0086655 / 7/16-14NCX1-3/4" LG.	0082384	0089880
0091004	13025 E	1-1/2"	1-1/2"	0086705 / 1/2-13NCX1-3/4" LG.	0082414	0089900
0091005	13025 F	2"	2"	0086705 / 1/2-13NCX1-3/4" LG.	0082444	0089920
0091006	13025 G	2-1/2"	2-1/2"	0086725 / 1/2-13NCX2-1/4" LG.	0082484	0089940
0091007	13025 H	3"	3"	0086775 / 5/8-11NCX2-3/4" LG.	0082534	0089960

*All capscrews must be socket head type.

†O-Ring numbers listed above are to be used only with fluids compatible with BUNA-N Compounds.

ORDERING EXAMPLE : 13025 B

SIZE CONN.

The items described in this document and other documents or descriptions provided by Parker Hannifin Corporation, its subsidiaries and its authorized distributors are hereby offered for sale at prices to be established by Parker Hannifin Corporation, its subsidiaries and its authorized distributors. This offer and its acceptance by any customer ("Buyer") shall be governed by all of the following Terms and Conditions. Buyer's order for any such items, when communicated to Parker Hannifin Corporation, its subsidiary or an authorized distributor ("Seller") verbally or in writing, shall constitute acceptance of this offer.

1. Terms and Conditions of Sale: All descriptions, quotations, proposals, offers, acknowledgments, acceptances and sales of Seller's products are subject to and shall be governed exclusively by the terms and conditions stated herein. Buyer's acceptance of any offer to sell is limited to these terms and conditions. Any terms or conditions in addition to, or inconsistent with those stated herein, proposed by Buyer in any acceptance of an offer by Seller, are hereby objected to. No such additional, different or inconsistent terms and conditions shall become part of the contract between Buyer and Seller unless expressly accepted in writing by Seller. Seller's acceptance of any offer to purchase by Buyer is expressly conditional upon Buyer's assent to all the terms and conditions stated herein, including any terms in addition to, or inconsistent with those contained in Buyer's offer. Acceptance of Seller's products shall in all events constitute such assent.

2. Payment: Payment shall be made by Buyer net 30 days from the date of delivery of the items purchased hereunder. Amounts not timely paid shall bear interest at the maximum rate permitted by law for each month or portion thereof that the Buyer is late in making payment. Any claims by Buyer for omissions or shortages in a shipment shall be waived unless Seller receives notice thereof within 30 days after Buyer's receipt of the shipment.

3. Delivery: Unless otherwise provided on the face hereof, delivery shall be made F.O.B. Seller's plant. Regardless of the method of delivery, however, risk of loss shall pass to Buyer upon Seller's delivery to a carrier. Any delivery dates shown are approximate only and Seller shall have no liability for any delays in delivery.

4. Warranty: Seller warrants that the items sold hereunder shall be free from defects in material or workmanship for a period of 18 months from date of shipment from Parker Hannifin Corporation. **THIS WARRANTY COMPRISES THE SOLE AND ENTIRE WARRANTY PERTAINING TO ITEMS PROVIDED HEREUNDER. SELLER MAKES NO OTHER WARRANTY, GUARANTEE, OR REPRESENTATION OF ANY KIND WHATSOEVER. ALL OTHER WARRANTIES, INCLUDING BUT NOT LIMITED TO, MERCHANTABILITY AND FITNESS FOR PURPOSE, WHETHER EXPRESS, IMPLIED, OR ARISING BY OPERATION OF LAW, TRADE USAGE, OR COURSE OF DEALING ARE HEREBY DISCLAIMED. NOTWITHSTANDING THE FOREGOING, THERE ARE NO WARRANTIES WHATSOEVER ON ITEMS BUILT OR ACQUIRED WHOLLY OR PARTIALLY, TO BUYER'S DESIGNS OR SPECIFICATIONS.**

5. Limitation Of Remedy: SELLER'S LIABILITY ARISING FROM OR IN ANY WAY CONNECTED WITH THE ITEMS SOLD OR THIS CONTRACT SHALL BE LIMITED EXCLUSIVELY TO REPAIR OR REPLACEMENT OF THE ITEMS SOLD OR REFUND OF THE PURCHASE PRICE PAID BY BUYER, AT SELLER'S SOLE OPTION. IN NO EVENT SHALL SELLER BE LIABLE FOR ANY INCIDENTAL, CONSEQUENTIAL OR SPECIAL DAMAGES OF ANY KIND OR NATURE WHATSOEVER, INCLUDING BUT NOT LIMITED TO LOST PROFITS ARISING FROM OR IN ANY WAY CONNECTED WITH THIS AGREEMENT OR ITEMS SOLD HEREUNDER, WHETHER ALLEGED TO ARISE FROM BREACH OF CONTRACT, EXPRESS OR IMPLIED WARRANTY, OR IN TORT, INCLUDING WITHOUT LIMITATION, NEGLIGENCE, FAILURE TO WARN OR STRICT LIABILITY.

6. Changes, Reschedules and Cancellations: Buyer may request to modify the designs or specifications for the items sold hereunder as well as the quantities and delivery dates thereof, or may request to cancel all or part of this order, however, no such requested modification or cancellation shall become part of the contract between Buyer and Seller unless accepted by Seller in a written amendment to this Agreement. Acceptance of any such requested modification or cancellation shall be at Seller's discretion, and shall be upon such terms and conditions as Seller may require.

7. Special Tooling: A tooling charge may be imposed for any special tooling, including without limitation, dies, fixtures, molds and patterns, acquired to manufacture items sold pursuant to this contract. Such special tooling shall be and remain Seller's property notwithstanding payment of any charges by Buyer. In no event will Buyer acquire any interest in apparatus belonging to Seller which is utilized in the notwithstanding any charges paid by Buyer. Unless otherwise agreed, Seller shall have the right to alter, discard or otherwise dispose of any special tooling or other property in its sole discretion at any time.

8. Buyer's Property: Any designs, tools, patterns, materials, drawings, confidential information or equipment furnished by Buyer or any other items which become Buyer's property, may be considered obsolete and may be destroyed by Seller after two (2) consecutive years have elapsed without Buyer placing an order for the items which are manufactured using such property, Seller shall not be responsible for any loss or damage to such property while it is in Seller's possession or control.

9. Taxes: Unless otherwise indicated on the face hereof, all prices and charges are exclusive of excise, sales, use, property, occupational or like taxes which may be imposed by any taxing authority upon the manufacture, sale or delivery of the items sold hereunder. If any such taxes must be paid by Seller or if Seller is liable for the collection of such tax, the amount thereof shall be in addition to the amounts for the items sold. Buyer agrees to pay all such taxes or to reimburse Seller therefore upon receipt of its invoice. If Buyer claims exemption from any sales, use or other tax imposed by any taxing authority, Buyer shall save Seller harmless from and against any such tax, together with any interest or penalties thereon which may be assessed if the items are held to be taxable.

10. Indemnity For Infringement of Intellectual Property Rights: Seller shall have no liability for infringement of any patents, trademarks, copyrights, trade dress, trade secrets or similar rights except as provided in this Part 10. Seller will defend and indemnify Buyer against allegations of infringement of U.S. Patents, U.S. Trademarks, copyrights, trade dress and trade secrets (hereinafter 'Intellectual Property Rights'). Seller will defend at its expense and will pay the cost of any settlement or damages awarded in an action brought against Buyer based on an allegation that an item sold pursuant to this contract infringes the Intellectual Property Rights of a third party. Seller's obligation to defend and indemnify Buyer is contingent on Buyer notifying Seller within ten (10) days after Buyer becomes aware of such allegations of infringement, and Seller having sole control over the defense of any allegations or actions including all negotiations for settlement or compromise. If an item sold hereunder is subject to a claim that it infringes the Intellectual Property Rights of a third party, Seller may, at its sole expense and option, procure for Buyer the right to continue using said item, replace or modify said item so as to make it noninfringing, or offer to accept return of said item and return the purchase price less a reasonable allowance for depreciation. Notwithstanding the foregoing, Seller shall have no liability for claims of infringement based on information provided by Buyer, or directed to items delivered hereunder for which the designs are specified in whole or part by Buyer, or infringements resulting from the modification, combination or use in a system of any item sold hereunder. The foregoing provisions of this Part 10 shall constitute Seller's sole and exclusive liability and Buyer's sole and exclusive remedy for infringement of Intellectual Property Rights.

If a claim is based on information provided by Buyer or if the design for an item delivered hereunder is specified in whole or in part by Buyer, Buyer shall defend and indemnify Seller for all costs, expenses or judgments resulting from any claim that such item infringes any patent, trademark, copyright, trade dress, trade secret or any similar right.

11. Force Majeure: Seller does not assume the risk of and shall not be liable for delay or failure to perform any of Seller's obligations by reason of circumstances beyond the reasonable control of Seller (hereinafter 'Events of Force Majeure'). Events of Force Majeure shall include without limitation, accidents, acts of God, strikes or labor disputes, acts, laws, rules or regulations of any government or government agency, fires, floods, delays or failures in delivery of carriers or suppliers, shortages of materials and any other cause beyond Seller's control.

12. Entire Agreement/Governing Law: The terms and conditions set forth herein, together with any amendments, modifications and any different terms or conditions expressly accepted by Seller in writing, shall constitute the entire Agreement concerning the items sold, and there are no oral or other representations or agreements which pertain thereto. This Agreement shall be governed in all respects by the law of the State of Ohio. No actions arising out of the sale of the items sold hereunder or this Agreement may be brought by either party more than two (2) years after the cause of action accrues.

9/91P



Parker Hannifin Corporation
 6035 Parkland Blvd.
 Cleveland, Ohio 44124-4141
 Telephone: (216) 896-3000
 Fax: (216) 896-4000
 Web site: www.parker.com

Parker Hannifin Corporation

About Parker Hannifin Corporation

Parker Hannifin is a leading global motion-control company dedicated to delivering premier customer service. A Fortune 500 corporation listed on the New York Stock Exchange (PH), our components and systems comprise over 1,400 product lines that control motion in some 1,000 industrial and aerospace markets. Parker is the only manufacturer to offer its customers a choice of hydraulic, pneumatic, and electromechanical motion-control solutions. Our Company has the largest distribution network in its field, with over 7,500 distributors serving more than 350,000 customers worldwide.

Parker's Charter

To be a leading worldwide manufacturer of components and systems for the builders and users of durable goods. More specifically, we will design, market and manufacture products controlling motion, flow and pressure. We will achieve profitable growth through premier customer service.

Product Information

North American customers seeking product information, the location of a nearby distributor, or repair services will receive prompt attention by calling the Parker Product Information Center at our toll-free number: 1-800-C-PARKER (1-800-272-7537). In the UK, a similar service is available by calling 0500-103-203.

The Aerospace Group

is a leader in the development, design, manufacture and servicing of control systems and components for aerospace and related high-technology markets, while achieving growth through premier customer service.



The Climate & Industrial Controls Group

designs, manufactures and markets system-control and fluid-handling components and systems to refrigeration, air-conditioning and industrial customers worldwide.



The Fluid Connectors Group

designs, manufactures and markets rigid and flexible connectors, and associated products used in pneumatic and fluid systems.



The Seal Group designs, manufactures and distributes industrial and commercial sealing devices and related products by providing superior quality and total customer satisfaction.



The Hydraulics Group

designs, produces and markets a full spectrum of hydraulic components and systems to builders and users of industrial and mobile machinery and equipment.



The Filtration Group

designs, manufactures and markets quality filtration and clarification products, providing customers with the best value, quality, technical support, and global availability.



The Automation Group

is a leading supplier of pneumatic and electro-mechanical components and systems to automation customers worldwide.



The Instrumentation Group

is a global leader in the design, manufacture and distribution of high-quality critical flow components for worldwide process instrumentation, ultra-high-purity, medical and analytical applications.





Parker Hannifin Corporation
Gear Pump Division
1775 Logan Avenue
Youngstown, OH 44501 USA
Tel: (330) 746-8011
Fax: (330) 746-1148
<http://www.parker.com/gearpump>

Catalog HY09-1000/US,
5M, 10/03, T&M